

RG2J

SINTERED GLASS JUNCTION FAST SWITCHING RECTIFIER

VOLTAGE: 600V

CURRENT: 2.0A



FEATURE

High temperature metallurgically bonded construction
Sintered glass cavity free junction
Capability of meeting environmental standard of MIL-S-19500
High temperature soldering guaranteed
350°C /10sec/0.375"lead length at 5 lbs tension
Operate at $T_a = 55^\circ\text{C}$ with no thermal runaway
Fast switching for high efficiency

MECHANICAL DATA

Case: SOD-57 sintered glass case
Terminal: Plated axial leads solderable per MIL-STD 202E, method 208C
Polarity: color band denotes cathode end
Mounting position: any

SOD-57

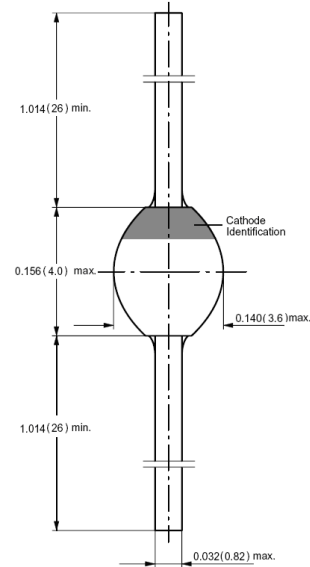

Dimensions in inches and (millimeters)

MAXIMUM RATINGS AND ELECTRICAL CHARACTERISTICS

(single-phase, half wave, 60HZ, resistive or inductive load rating at 25°C , unless otherwise stated)

	SYMBOL	RG2J	units
Maximum Recurrent Peak Reverse Voltage	V _{rrm}	600	V
Maximum RMS Voltage	V _{rms}	420	V
Maximum DC blocking Voltage	V _{dc}	600	V
Maximum Average Forward Rectified Current 3/8"lead length at $T_a = 55^\circ\text{C}$	I _{f(av)}	2.0	A
Peak Forward Surge Current 8.3ms single half sine-wave superimposed on rated load	I _{fsm}	50	A
Maximum Forward Voltage at rated Forward Current and 25°C	V _f	1.3	V
Maximum full load reverse current full cycle average 0.375"(9.5MM) lead length at $T_a = 100^\circ\text{C}$	I _{r(av)}	100	μA
Maximum DC Reverse Current at rated DC blocking voltage	I _r	5.0 100	μA
Typical Reverse Recovery Time (Note 1)	T _{rr}	200	nS
Typical Junction Capacitance (Note 2)	C _j	15	pF
Typical Thermal Resistance (Note 3)	R _{th(ja)}	55	$^\circ\text{C}/\text{W}$
Storage and Operating Temperature Range	T _{stg} , T _j	-65 to +175	$^\circ\text{C}$

Note:

1. Reverse Recovery Condition $I_f = 0.5\text{A}$, $I_r = 1.0\text{A}$, $I_{rr} = 0.25\text{A}$
2. Measured at 1.0 MHz and applied reverse voltage of 4.0Vdc
3. Thermal Resistance from Junction to Ambient at 3/8"lead length, P.C. Board Mounted

RATINGS AND CHARACTERISTIC CURVES RG2J

FIG. 1 - FORWARD CURRENT DERATING CURVE

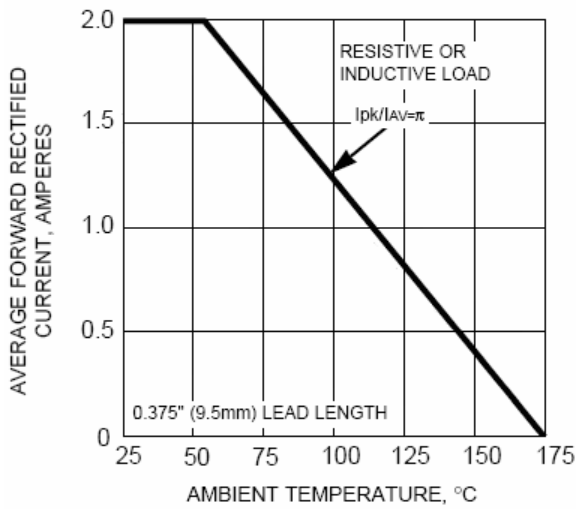

FIG. 2 - MAXIMUM NON-REPETITIVE PEAK FORWARD SURGE CURRENT

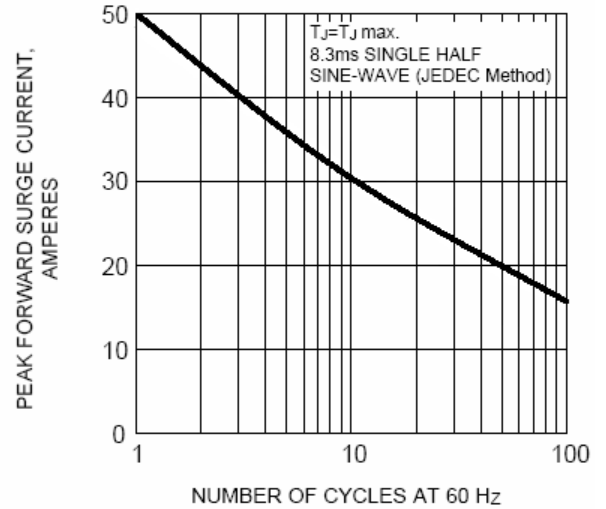

FIG. 3 - TYPICAL INSTANTANEOUS FORWARD CHARACTERISTICS

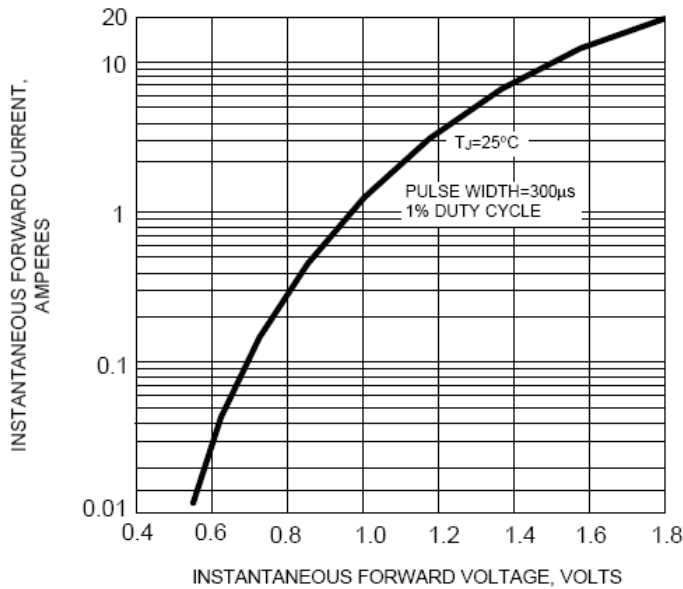

FIG. 4 - TYPICAL REVERSE CHARACTERISTICS

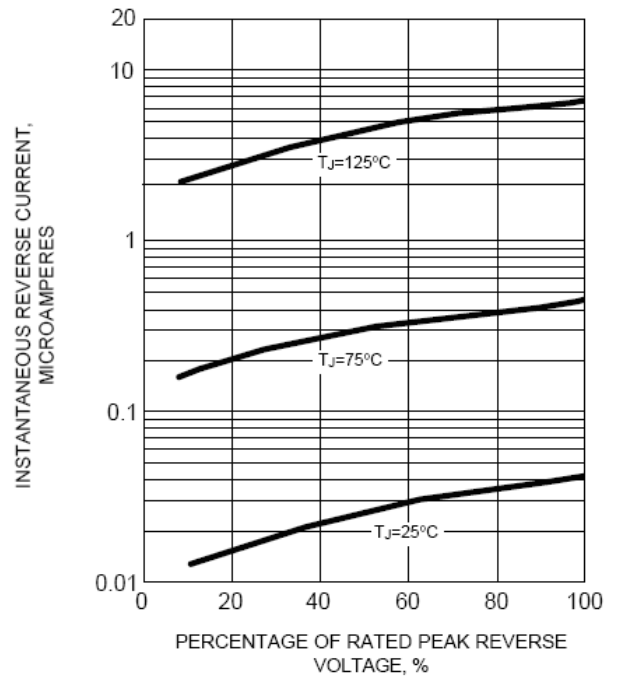

FIG. 5 - TYPICAL JUNCTION CAPACITANCE

