

■ Features

- Fast switching.
- ESD improved capability.
- Low gate charge.
- Low reverse transfer capacitances.
- 100% single pulse avalanche energy test.

■ Mechanical data

- Epoxy : UL94-V0 rated flame retardant.
- Case : JEDEC TO-220F molded plastic body.
- Terminals : Solder plated, solderable per MIL-STD-750, Method 2026.
- Polarity: As marked.
- Mounting Position : Any.
- Weight : Approximated 2.25 gram.

■ Outline

TO-220F

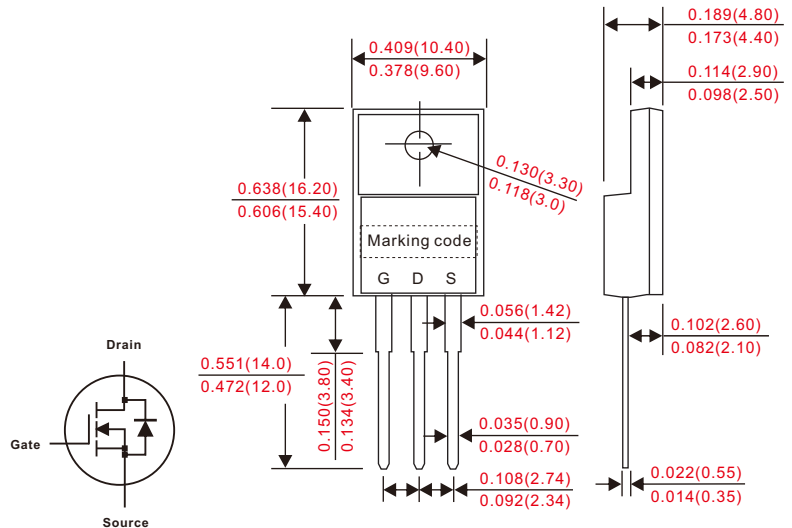

■ Absolute ($T_c = 25^\circ\text{C}$ unless otherwise specified)

PARAMETER	CONDITIONS	Symbol	CS8N60FA9H	UNIT
Drain-Source Voltage		V_{DSS}	600	V
Continuous Drain Current		I_D	8	A
Continuous Drain Current	$T_c = 100^\circ\text{C}$		5.5	
Pulsed Drain Current(1)		I_{DM}	32	
Gate-Source Voltage		V_{GS}	± 30	V
Single Pulse Avalanche Energy(2)		E_{AS}	600	mJ
Avalanche Current(1)		I_{AR}	3.5	A
Repetitive Avalanche Energy(1)		E_{AR}	60	mJ
Power Dissipation		P_D	45	W
	Derating factor above 25°C		0.36	W/ $^\circ\text{C}$
Peak Diode Recovery dv/dt(3)		dV/dt	5.0	V/ns
Operating and Storage Temperature Range		T_J, T_{STG}	-55 ~ +150	$^\circ\text{C}$
Maximum temperature for soldering		T_L	300	$^\circ\text{C}$

NOTE : 1.Repetitive rating; pulse width limited by maximum junction temperature.

2.L=10.0mH, $I_o = 10.9\text{A}$, Start $T_J = 25^\circ\text{C}$.

3. $I_{SD} = 8\text{A}$, $di/dt \leq 100\text{A/us}$, $V_{DS} \leq BV_{DS}$, Start $T_J = 25^\circ\text{C}$.

■ Electrical characteristics($T_c = 25^\circ\text{C}$ unless otherwise specified)						
PARAMETER	CONDITIONS	Symbol	MIN.	TYP.	MAX.	UNIT
Drain-Source Breakdown Voltage	$V_{GS} = 0V, I_D = 250\mu\text{A}$	V_{DSS}	600			V
Bvdss Temperature Coefficient	$I_D = 250\mu\text{A}$, Reference 25°C	BV_{DSS} / T_J		0.74		$\text{V}/^\circ\text{C}$
Drain-Source Leakage Current	$V_{DS} = 600V, V_{GS} = 0V, T_a = 25^\circ\text{C}$	I_{DSS}			1	uA
	$V_{DS} = 480V, V_{GS} = 0V, T_a = 125^\circ\text{C}$				100	
Gate-Source Leakage Current, Forward	$V_{GS} = 30V$	$I_{GSS(F)}$			100	nA
Gate-Source Leakage Current, Reverse	$V_{GS} = -30V$	$I_{GSS(R)}$			-100	
■ ON Characteristics						
PARAMETER	CONDITIONS	Symbol	MIN.	TYP.	MAX.	UNIT
Gate Threshold Voltage	$V_{DS} = V_{GS}, I_D = 250\mu\text{A}$	$V_{GS(th)}$	2.0		4.0	V
Static Drain-Source On-Resistance	$V_{GS} = 10V, I_D = 4A$	$R_{DS(on)}$		0.8	1.2	Ω
■ Dynamic Characteristics						
PARAMETER	CONDITIONS	Symbol	MIN.	TYP.	MAX.	UNIT
Forward Transconductance	$V_{DS} = 15V, I_D = 4A$	g_{fs}		7		S
Input Capacitance	$V_{DS} = 25V, V_{GS} = 0V, f = 1.0\text{MHz}$	C_{iss}		1253		pF
Output Capacitance		C_{oss}		115		
Reverse Transfer Capacitance		C_{rss}		15		
■ Resistive Switching Characteristics						
PARAMETER	CONDITIONS	Symbol	MIN.	TYP.	MAX.	UNIT
Turn-on Delay Time	$I_D = 8A, V_{DD} = 300V, V_{GS} = 10V, R_G = 9.1\Omega$	$td_{(ON)}$		13		ns
Rise Time		tr		15		
Turn-off Delay Time		$td_{(OFF)}$		41		
Fail Time		tf		21		
Total Gate Charge	$I_D = 8A, V_{DD} = 300V, V_{GS} = 10V$	Q_g		29		nC
Gate-Source Charge		Q_{gs}		7		
Gate-Drain Charge		Q_{gd}		12		
■ Source-Drain Diode Characteristics						
PARAMETER	CONDITIONS	Symbol	MIN.	TYP.	MAX.	UNIT
Continuous Source-Drain Diode Current	Body Diode	I_S			8	A
Pulse Diode Forward Current	Body Diode	I_{SM}			32	
Body Diode Voltage	$I_S = 8.0A, V_{GS} = 0V$	V_{SD}			1.5	V
Reverse recovery time	$I_S = 8A, T_J = 25^\circ\text{C}, di_f/dt = 100A/\mu\text{s}, V_{GS} = 0V$	t_{rr}		406		ns
Reverse recovery charge		Q_{rr}			1895	
■ Thermal characteristics						
PARAMETER	CONDITIONS	Symbol	MIN.	TYP.	MAX.	UNIT
Thermal Resistance	Junction to Case	$R_{\theta JC}$		2.78		$^\circ\text{C}/\text{W}$
	Junction to Ambient	$R_{\theta JA}$		100		

Rating and characteristic curves

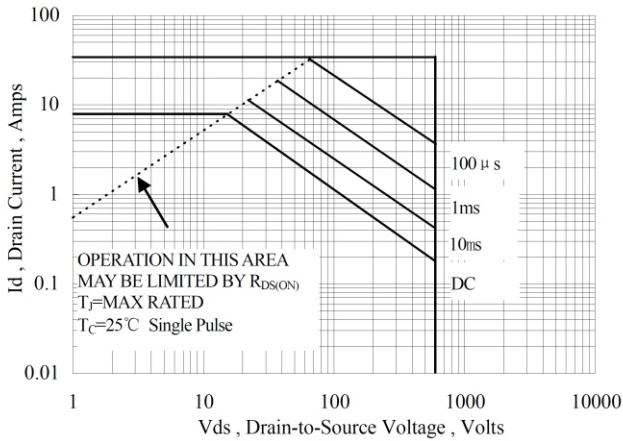

Figure 1 Maximum Forward Bias Safe Operating Area

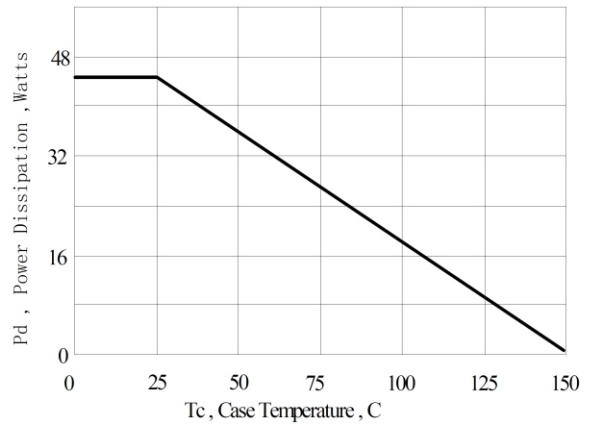

Figure 2 Maximum Power Dissipation vs Case Temperature

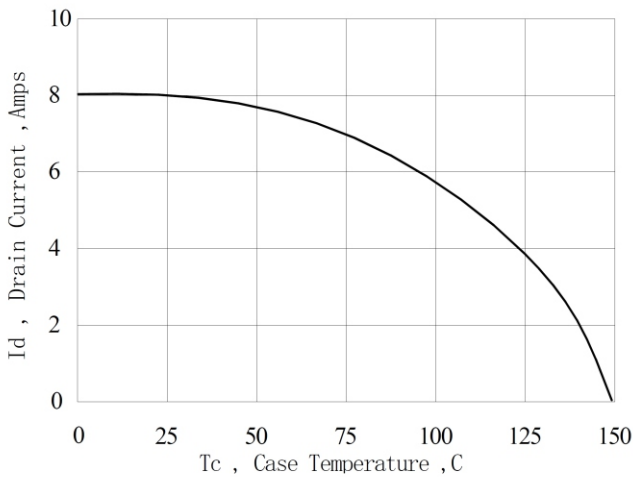

Figure 3 Maximum Continuous Drain Current vs Case Temperature

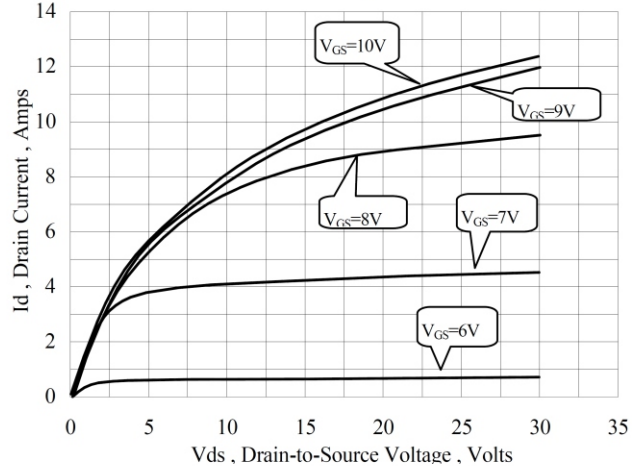

Figure 4 Typical Output Characteristics

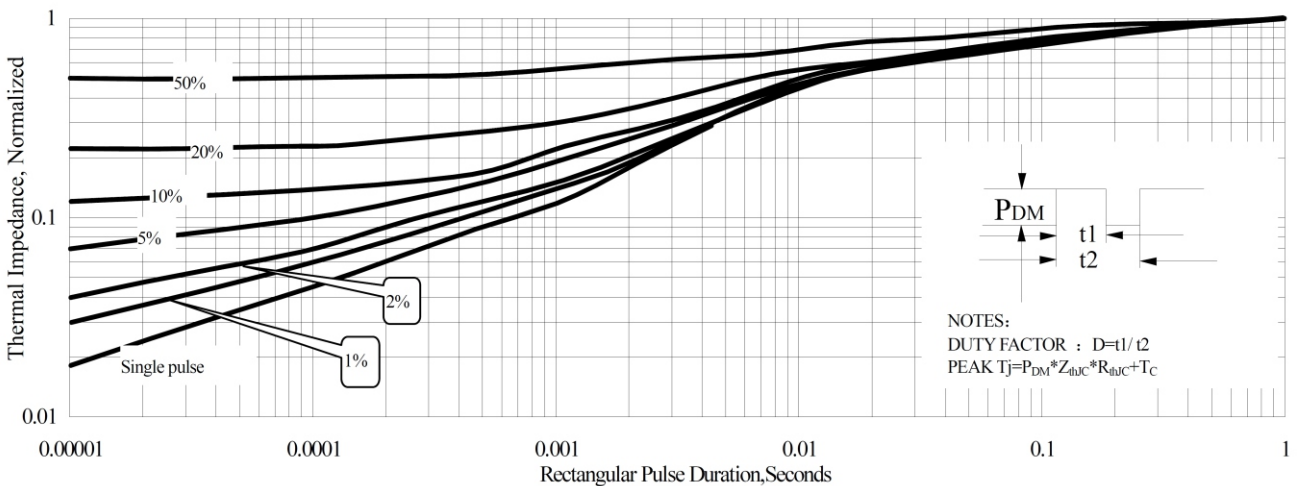

Figure 5 Maximum Effective Thermal Impedance, Junction to Case

Rating and characteristic curves

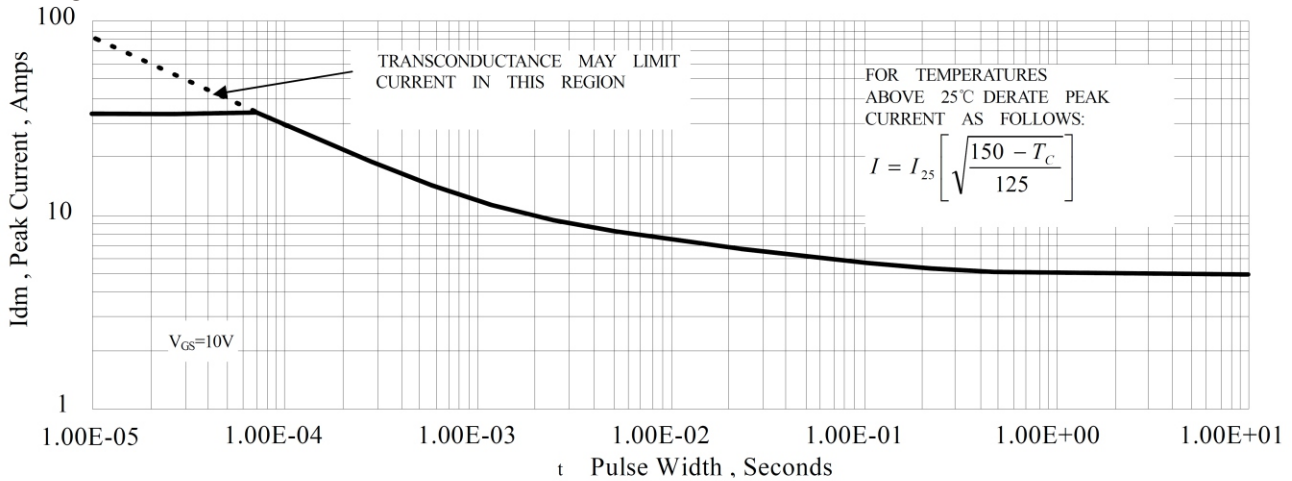

Figure 6 Maximum Peak Current Capability

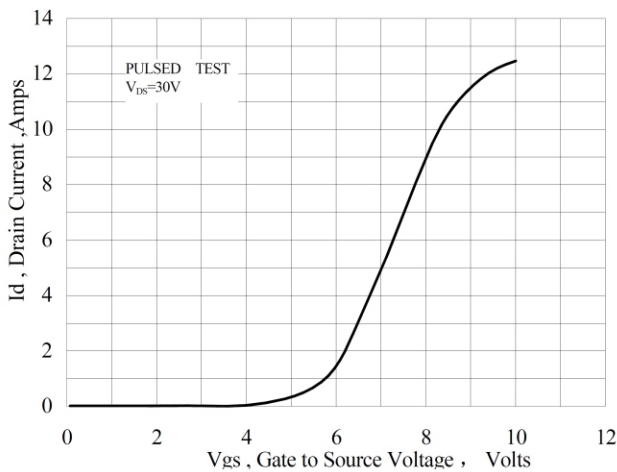

Figure 7 Typical Transfer Characteristics

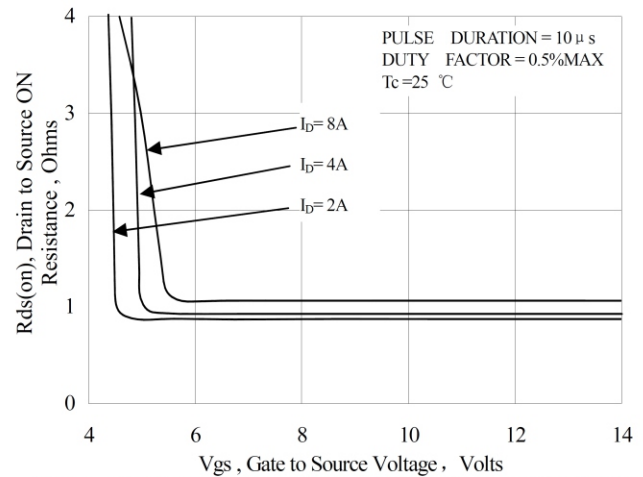

Figure 8 Typical Drain to Source ON Resistance vs Gate Voltage and Drain Current

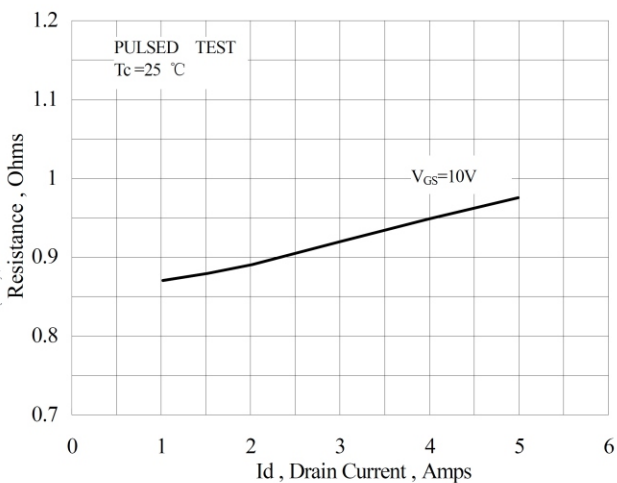

Figure 9 Typical Drain to Source ON Resistance vs Drain Current

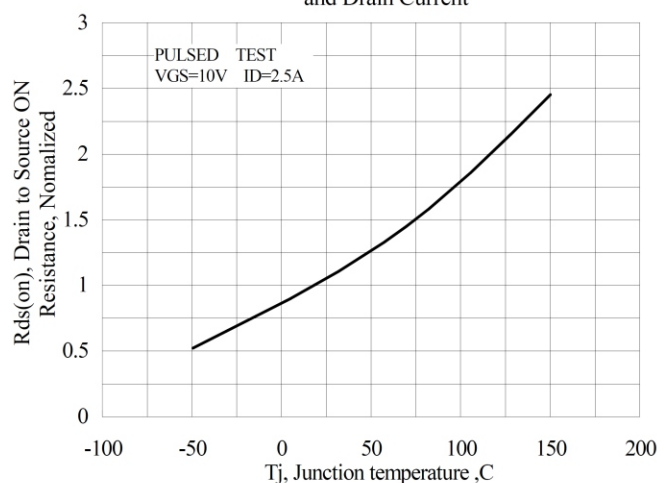

Figure 10 Typical Drain to Source on Resistance vs Junction Temperature

Rating and characteristic curves

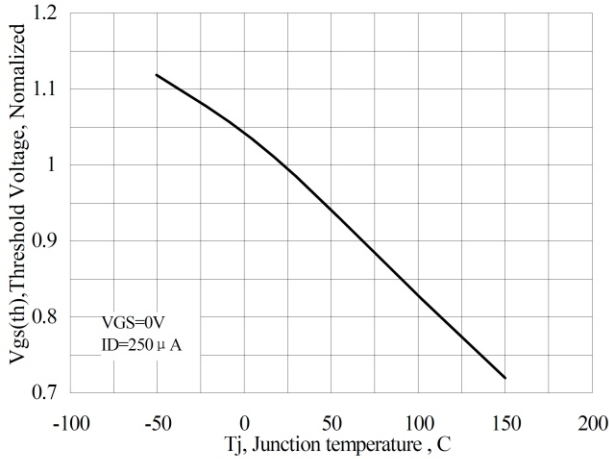

Figure 11 Typical Threshold Voltage vs Junction Temperature

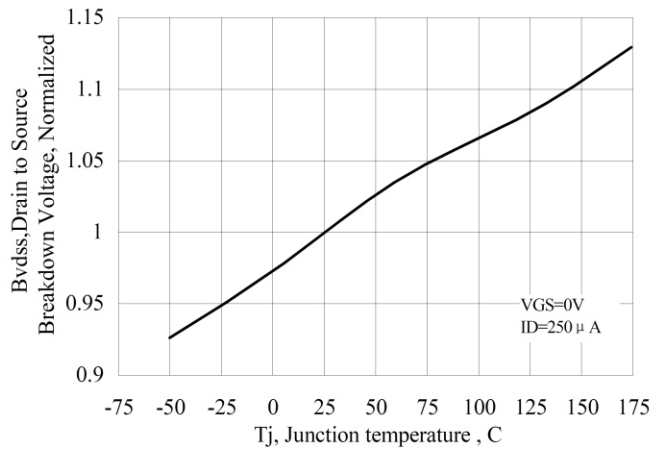

Figure 12 Typical Breakdown Voltage vs Junction Temperature

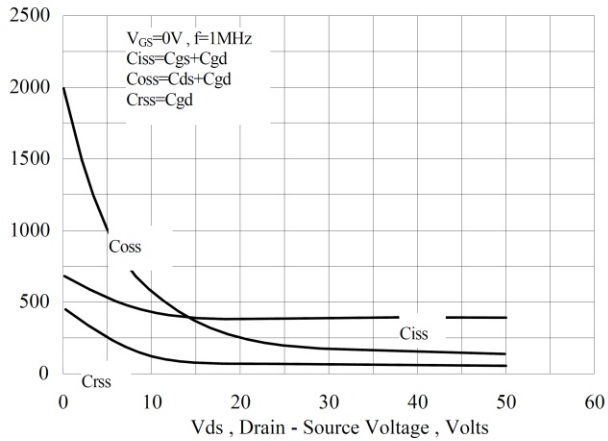

Figure 13 Typical Capacitance vs Drain to Source Voltage

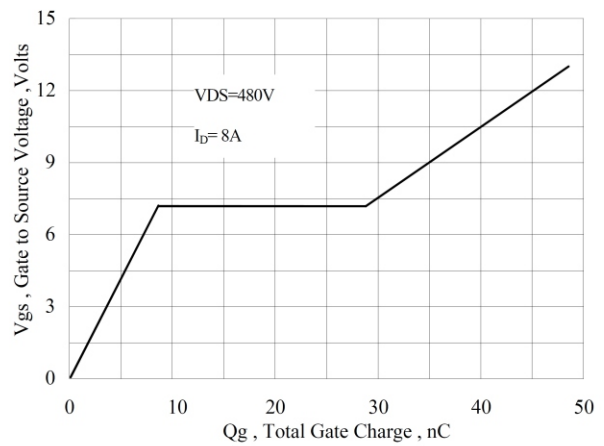

Figure 14 Typical Gate Charge vs Gate to Source Voltage

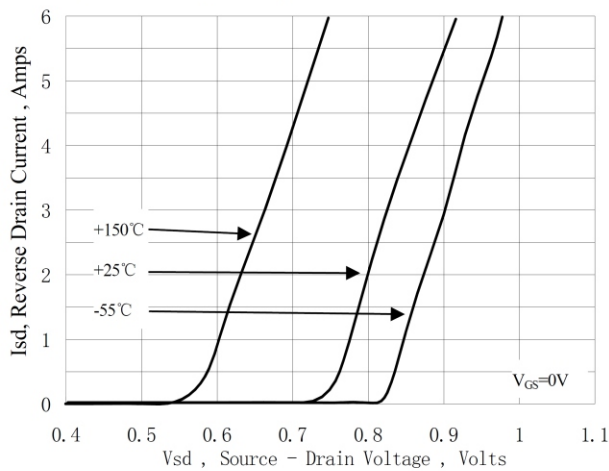

Figure 15 Typical Body Diode Transfer Characteristics

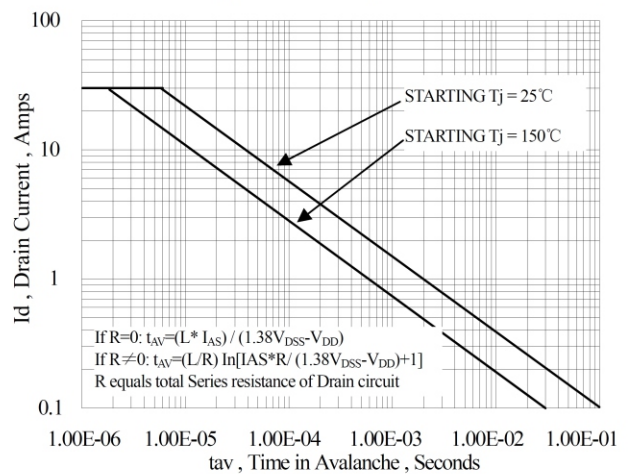

Figure 16 Unclamped Inductive Switching Capability

■ Test circuit and waveform

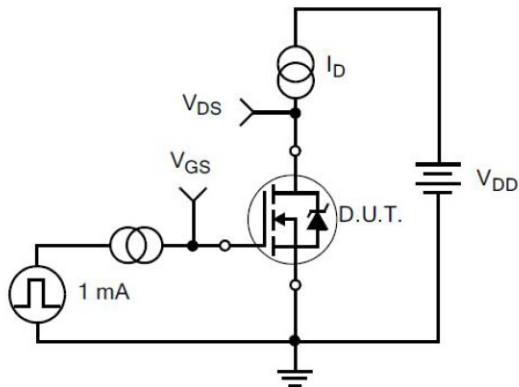

Figure 17. Gate Charge Test Circuit

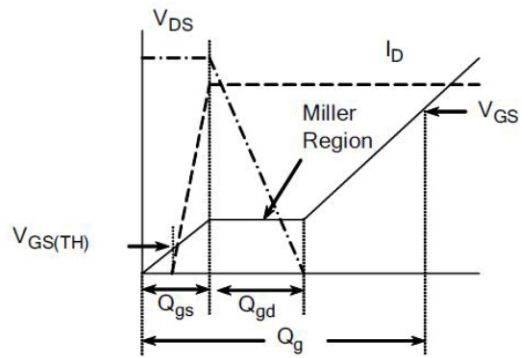

Figure 18. Gate Charge Waveform

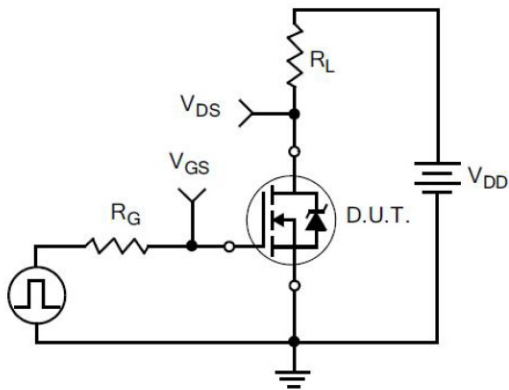

Figure 19. Resistive Switching Test Circuit

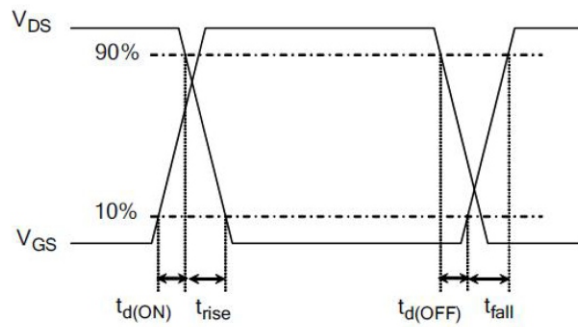

Figure 20. Resistive Switching Waveforms

■ Test circuit and waveform

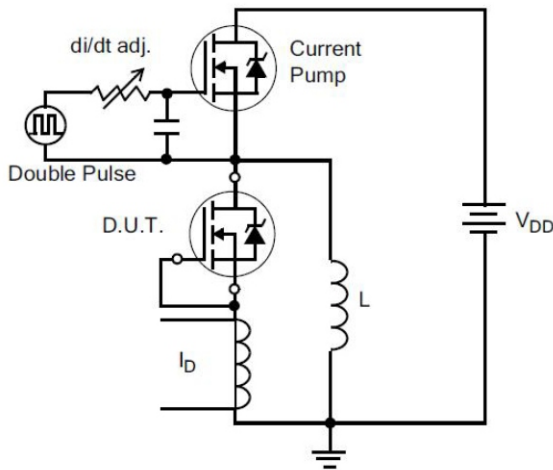

Figure 21. Diode Reverse Recovery Test Circuit

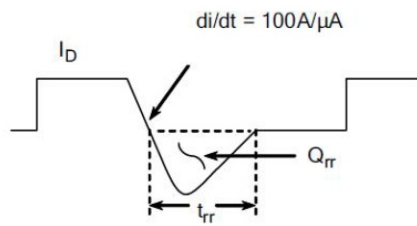

Figure 22. Diode Reverse Recovery Waveform

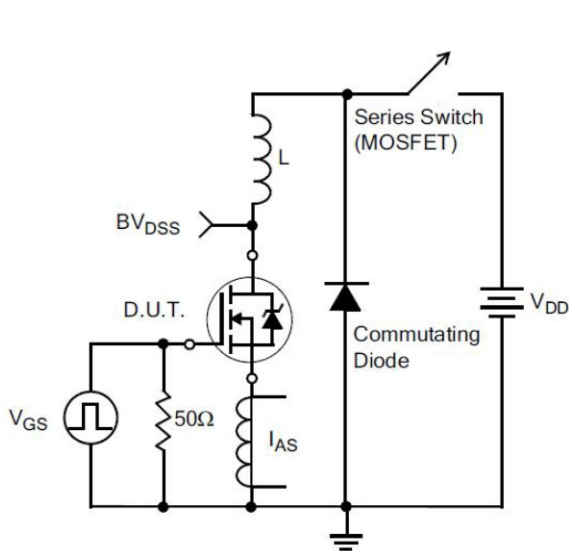

Figure 23. Unclamped Inductive Switching Test Circuit

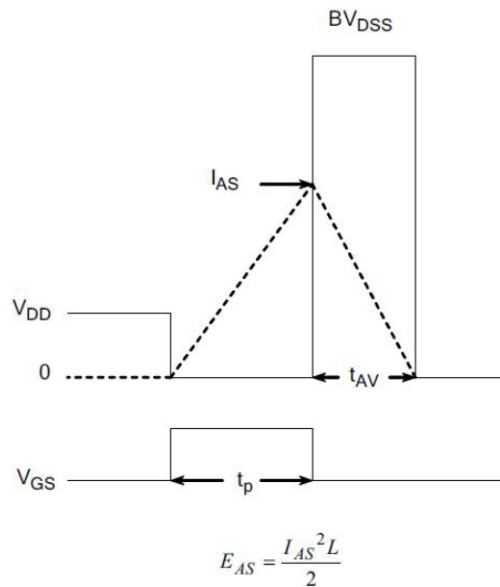

Figure 24. Unclamped Inductive Switching Waveforms

- CITC reserves the right to make changes to this document and its products and specifications at any time without notice.
- Customers should obtain and confirm the latest product information and specifications before final design, purchase or use.
- CITC makes no warranty, representation or guarantee regarding the suitability of its products for any particular purpose, nor does CITC assume any liability for application assistance or customer product design.
- CITC does not warrant or accept any liability with products which are purchased or used for any unintended or unauthorized application.
- No license is granted by implication or otherwise under any intellectual property rights of CITC.
- CITC products are not authorized for use as critical components in life support devices or systems without express written approval of CITC.