

■ Features

- Dual rectifier construction, positive centetap, offer 10.0A half wave and 20.0A full wave rectification.
- Low power loss, high efficiency.
- High surge current capability.
- Super fast recovery time for switching mode application.
- Low power loss.
- Glass passivated chip junctions.
- Suffix "G" indicates Halogen-free part, ex. ET20005CTG.
- Lead-free parts meet environmental standards of MIL-STD-19500 /228

■ Mechanical data

- Epoxy : UL94-V0 rated flame retardant.
- Case : JEDEC TO-220AB molded plastic body over passivated chip.
- Lead : Axial leads, solderable per MIL-STD-202, Method 208 guranteed.
- Polarity: Color band denotes cathode end.
- Mounting Position : Any.
- Weight : Approximated 2.25 gram.

■ Maximum ratings and electrical characteristics

Rating at 25°C ambient temperature unless otherwise specified. Single phase, half wave, 60Hz, resistive or inductive load. For capacitive load, derate current by 20%.

■ Outline

TO-220AB

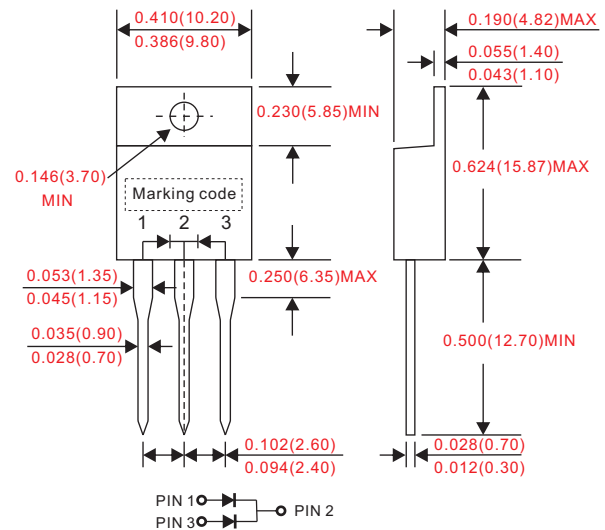

Parameter	Conditions	Symbol	MIN.	TYP.	MAX.	UNIT
Forward rectified current		I_o			20	A
Forward surge current	8.3ms single half sine-wave superimposed on rate load (JEDEC method)	I_{FSM}			150	A
Reverse current	$V_R = V_{RRM}$ $T_A = 25^\circ\text{C}$	I_R			1.0	uA
	$V_R = V_{RRM}$ $T_A = 125^\circ\text{C}$				300	
Diode junction capacitance	f=1MHz and applied 4V DC reverse voltage	C_j		85		pF
Storage temperature		T_{STG}	-50		+150	°C

Symbol	Marking code	Max. repetitive peak reverse voltage V_{RRM} (V)	Max. RMS voltage V_{RMS} (V)	Max. DC blocking voltage V_R (V)	Max. forward voltage @10A, $T_A = 25^\circ\text{C}$ V_F (V)	Max. reverse recovery time(1) T_{rr} (ns)	Operating temperature T_J (°C)
ET20005CT	ET20005CT	50	35	50	0.95	35	-50 ~ +150
ET2001CT	ET2001CT	100	70	100			
ET2002CT	ET2002CT	200	140	200			
ET2004CT	ET2004CT	400	280	400	1.70	75	
ET2006CT	ET2006CT	600	420	600			
ET2008CT	ET2008CT	800	560	800			
ET2010CT	ET2010CT	1000	700	1000			

Note : 1. $I_F = 0.5A$, $I_R = 1.0A$, $I_{RR} = 0.25A$

Rating and characteristic curves

Fig.1 - Forward Current Derating Curve

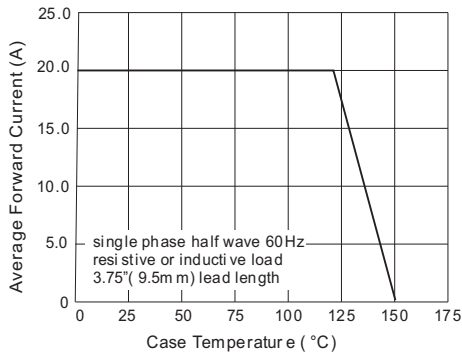

Fig. 2 - Maximum Non-Repetitive Peak Forward Surge Current

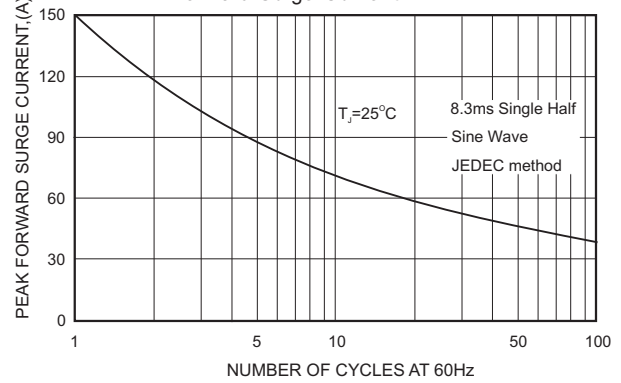

Fig. 3 - Typical Instantaneous Forward Characteristics

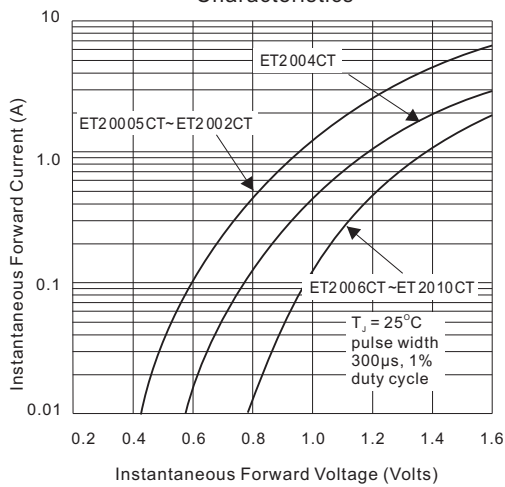

Fig. 4 - Typical Reverse Characteristics

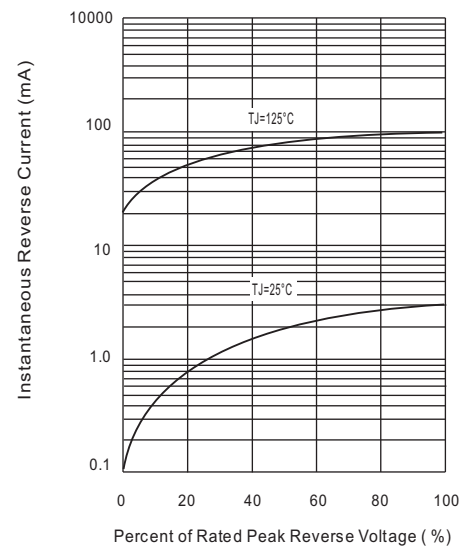
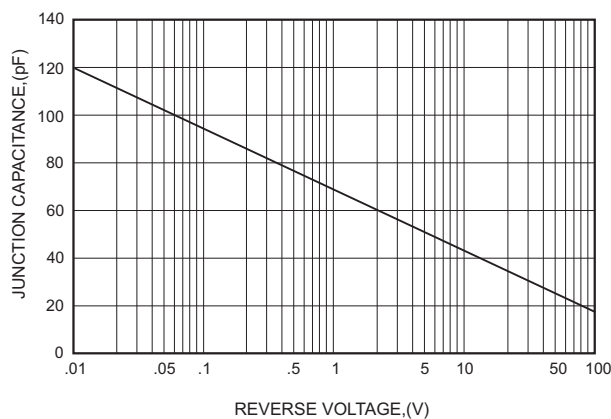

Fig. 5 - Typical Junction Capacitance



- CITC reserves the right to make changes to this document and its products and specifications at any time without notice.
- Customers should obtain and confirm the latest product information and specifications before final design, purchase or use.
- CITC makes no warranty, representation or guarantee regarding the suitability of its products for any particular purpose, nor does CITC assume any liability for application assistance or customer product design.
- CITC does not warrant or accept any liability with products which are purchased or used for any unintended or unauthorized application.
- No license is granted by implication or otherwise under any intellectual property rights of CITC.
- CITC products are not authorized for use as critical components in life support devices or systems without express written approval of CITC.