

Features

- Planar Die Construction
- 500mW Power Dissipation
- 2.0 – 56V Nominal Zener Voltage
- Ideally Suited for Automated Assembly
- For Use in Voltage Stabilizer or Reference

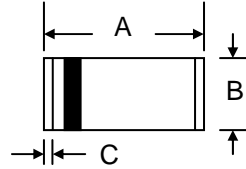

Mechanical Data

- Case: MiniMELF, Molded Glass
- Terminals: Plated Leads Solderable per MIL-STD-202, Method 208
- Polarity: Cathode Band
- Weight: 0.03 grams
- Marking: Device Code
- **Lead Free: For RoHS / Lead Free Version, Add “-LF” Suffix to Part Number, See Page 6**

MiniMELF		
Dim	Min	Max
A	3.30	3.70
B	1.30	1.60
C	0.28	0.50
All Dimensions in mm		

Maximum Ratings @ $T_A=25^\circ\text{C}$ unless otherwise specified

Characteristic	Symbol	Value	Unit
Peak Pulse Power Dissipation at $T_A = 25^\circ\text{C}$ (Note 1)	P_D	500	mW
Forward Voltage @ $I_F = 100\text{mA}$	V_F	1.0	V
Thermal Resistance Junction to Ambient (Note 1)	R_{JA}	0.3	$^\circ\text{C}/\text{mW}$
Operating and Storage Temperature Range	T_J, T_{STG}	-55 to +175	$^\circ\text{C}$

Note: 1. Mounted on ceramic substrate with minimum recommended pad layout.

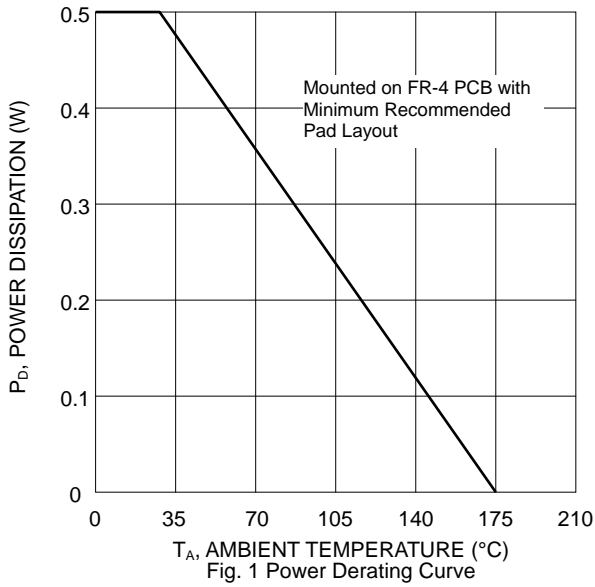

Fig. 1 Power Derating Curve

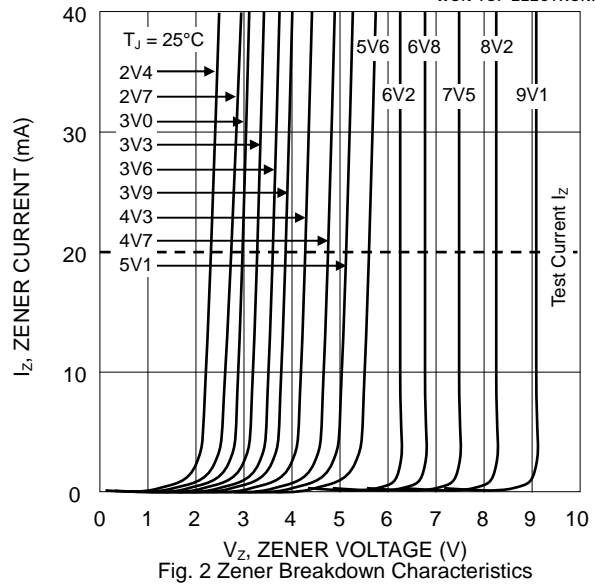

Fig. 2 Zener Breakdown Characteristics

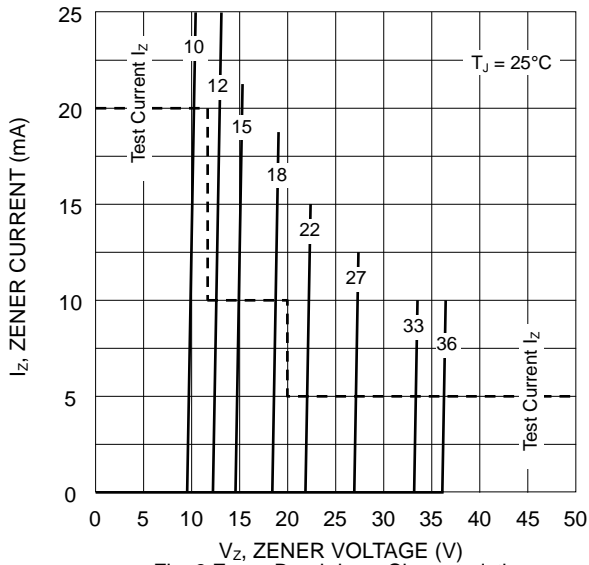

Fig. 3 Zener Breakdown Characteristics

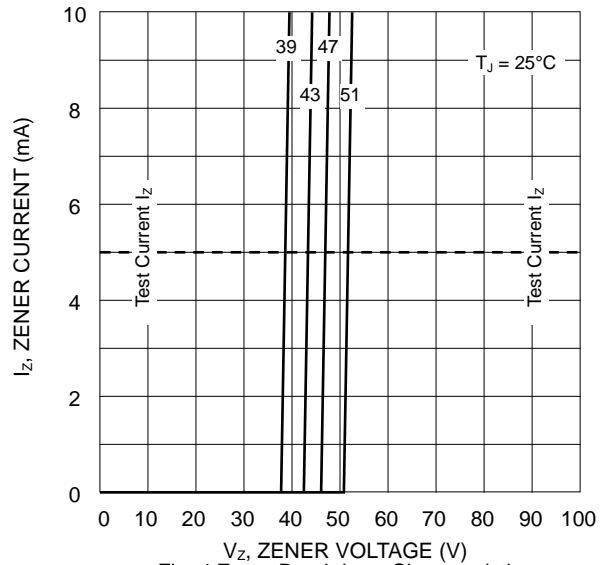

Fig. 4 Zener Breakdown Characteristics

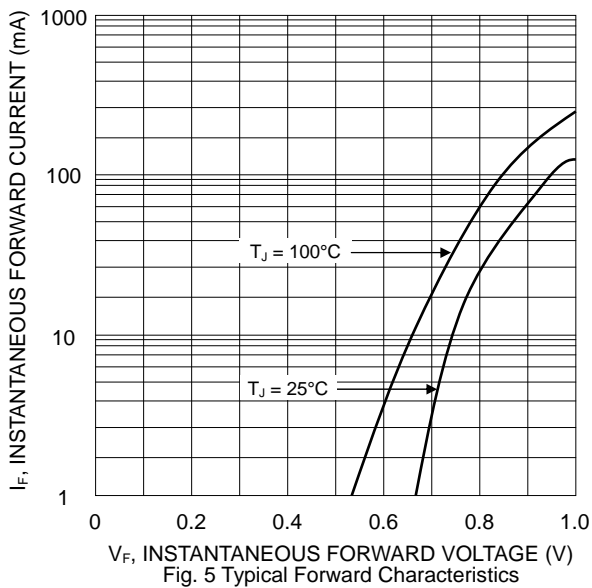

Fig. 5 Typical Forward Characteristics

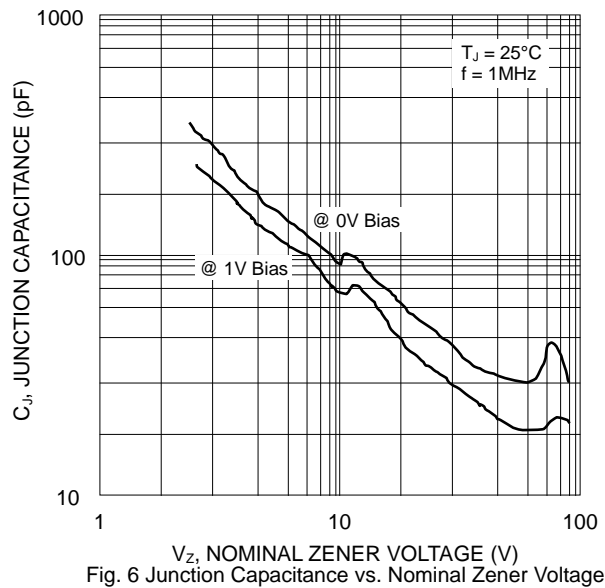

Fig. 6 Junction Capacitance vs. Nominal Zener Voltage

Electrical Characteristics (@T_A=25°C unless otherwise specified) Table 1

Type Number	Device Marking Code	Zener Voltage Range (Note 1)			Maximum Zener Impedance (Note 2)				Max Reverse Leakage Current	
		V _Z @ I _{ZT}			Z _{ZT} @ I _{ZT}		Z _{ZK} @ I _{ZK}		I _R @ V _R	
		Nom (V)	Min (V)	Max (V)	()	(mA)	()	(mA)	(μA)	(V)
GLZ2.0A	2A0	2.0	1.88	2.10	140	20	2000	1.0	120	0.5
GLZ2.0B	2B0	2.0	2.02	2.20	140	20	2000	1.0	120	0.5
GLZ2.2A	2A2	2.2	2.12	2.30	120	20	2000	1.0	120	0.7
GLZ2.2B	2B2	2.2	2.22	2.41	120	20	2000	1.0	120	0.7
GLZ2.4A	2A4	2.4	2.33	2.52	100	20	2000	1.0	120	1.0
GLZ2.4B	2B4	2.4	2.43	2.63	100	20	2000	1.0	120	1.0
GLZ2.7A	2A7	2.7	2.54	2.75	100	20	1000	1.0	120	1.0
GLZ2.7B	2B7	2.7	2.69	2.91	100	20	1000	1.0	120	1.0
GLZ3.0A	3A0	3.0	2.85	3.07	80	20	1000	1.0	50	1.0
GLZ3.0B	3B0	3.0	3.01	3.22	80	20	1000	1.0	50	1.0
GLZ3.3A	3A3	3.3	3.16	3.38	70	20	1000	1.0	20	1.0
GLZ3.3B	3B3	3.3	3.32	3.53	70	20	1000	1.0	20	1.0
GLZ3.6A	3A6	3.6	3.46	3.69	60	20	1000	1.0	10	1.0
GLZ3.6B	3B6	3.6	3.60	3.84	60	20	1000	1.0	10	1.0
GLZ3.9A	3A9	3.9	3.74	4.01	50	20	1000	1.0	5.0	1.0
GLZ3.9B	3B9	3.9	3.89	4.16	50	20	1000	1.0	5.0	1.0
GLZ4.3A	4A3	4.3	4.04	4.29	40	20	1000	1.0	5.0	1.0
GLZ4.3B	4B3	4.3	4.17	4.43	40	20	1000	1.0	5.0	1.0
GLZ4.3C	4C3	4.3	4.30	4.57	40	20	1000	1.0	5.0	1.0
GLZ4.7A	4A7	4.7	4.44	4.68	25	20	900	1.0	5.0	1.0
GLZ4.7B	4B7	4.7	4.55	4.80	25	20	900	1.0	5.0	1.0
GLZ4.7C	4C7	4.7	4.68	4.93	25	20	900	1.0	5.0	1.0
GLZ5.1A	5A1	5.1	4.81	5.07	20	20	800	1.0	5.0	1.5
GLZ5.1B	5B1	5.1	4.94	5.20	20	20	800	1.0	5.0	1.5
GLZ5.1C	5C1	5.1	5.09	5.37	20	20	800	1.0	5.0	1.5
GLZ5.6A	5A6	5.6	5.28	5.55	13	20	500	1.0	5.0	2.5
GLZ5.6B	5B6	5.6	5.45	5.73	13	20	500	1.0	5.0	2.5
GLZ5.6C	5C6	5.6	5.61	5.91	13	20	500	1.0	5.0	2.5
GLZ6.2A	6A2	6.2	5.78	6.09	10	20	300	1.0	5.0	3.0
GLZ6.2B	6B2	6.2	5.96	6.27	10	20	300	1.0	5.0	3.0
GLZ6.2C	6C2	6.2	6.12	6.44	10	20	300	1.0	5.0	3.0
GLZ6.8A	6A8	6.8	6.29	6.63	8.0	20	150	0.5	2.0	3.5
GLZ6.8B	6B8	6.8	6.49	6.83	8.0	20	150	0.5	2.0	3.5
GLZ6.8C	6C8	6.8	6.66	7.01	8.0	20	150	0.5	2.0	3.5
GLZ7.5A	7A5	7.5	6.85	7.22	8.0	20	120	0.5	0.5	4.0
GLZ7.5B	7B5	7.5	7.07	7.45	8.0	20	120	0.5	0.5	4.0
GLZ7.5C	7C5	7.5	7.29	7.67	8.0	20	120	0.5	0.5	4.0
GLZ8.2A	8A2	8.2	7.53	7.92	8.0	20	120	0.5	0.5	5.0
GLZ8.2B	8B2	8.2	7.78	8.19	8.0	20	120	0.5	0.5	5.0
GLZ8.2C	8C2	8.2	8.03	8.45	8.0	20	120	0.5	0.5	5.0
GLZ9.1A	9A1	9.1	8.29	8.73	8.0	20	120	0.5	0.5	6.0
GLZ9.1B	9B1	9.1	8.57	9.01	8.0	20	120	0.5	0.5	6.0
GLZ9.1C	9C1	9.1	8.83	9.30	8.0	20	120	0.5	0.5	6.0
GLZ10A	10A	10	9.12	9.59	8.0	20	120	0.5	0.2	7.0
GLZ10B	10B	10	9.41	9.90	8.0	20	120	0.5	0.2	7.0
GLZ10C	10C	10	9.70	10.20	8.0	20	120	0.5	0.2	7.0
GLZ10D	10D	10	9.94	10.44	8.0	20	120	0.5	0.2	7.0
GLZ11A	11A	11	10.18	10.71	10	10	120	0.5	0.2	8.0
GLZ11B	11B	11	10.50	11.05	10	10	120	0.5	0.2	8.0
GLZ11C	11C	11	10.82	11.38	10	10	120	0.5	0.2	8.0
GLZ12A	12A	12	11.13	11.71	12	10	110	0.5	0.2	9.0
GLZ12B	12B	12	11.44	12.03	12	10	110	0.5	0.2	9.0
GLZ12C	12C	12	11.74	12.35	12	10	110	0.5	0.2	9.0

Electrical Characteristics (@T_A=25°C unless otherwise specified) Table 1 (Cont'd)

Type Number	Device Marking Code	Zener Voltage Range (Note 1)			Maximum Zener Impedance (Note 2)				Max Reverse Leakage Current	
		V _Z @ I _{ZT}			Z _{ZT} @ I _{ZT}		Z _{ZK} @ I _{ZK}		I _R @ V _R	
		Nom (V)	Min (V)	Max (V)	()	(mA)	()	(mA)	(μA)	(V)
GLZ13A	13A	13	12.11	12.75	14	10	110	0.5	0.2	10
GLZ13B	13B	13	12.55	13.21	14	10	110	0.5	0.2	10
GLZ13C	13C	13	12.99	13.66	14	10	110	0.5	0.2	10
GLZ15A	15A	15	13.44	14.13	16	10	110	0.5	0.2	11
GLZ15B	15B	15	13.89	14.62	16	10	110	0.5	0.2	11
GLZ15C	15C	15	14.35	15.09	16	10	110	0.5	0.2	11
GLZ16A	16A	16	14.80	15.57	18	10	150	0.5	0.2	12
GLZ16B	16B	16	15.25	16.04	18	10	150	0.5	0.2	12
GLZ16C	16C	16	15.69	16.51	18	10	150	0.5	0.2	12
GLZ18A	18A	18	16.22	17.06	23	10	150	0.5	0.2	13
GLZ18B	18B	18	16.82	17.70	23	10	150	0.5	0.2	13
GLZ18C	18C	18	17.42	18.33	23	10	150	0.5	0.2	13
GLZ20A	20A	20	18.02	18.96	28	10	200	0.5	0.2	15
GLZ20B	20B	20	18.63	19.59	28	10	200	0.5	0.2	15
GLZ20C	20C	20	19.23	20.22	28	10	200	0.5	0.2	15
GLZ20D	20D	20	19.72	20.72	28	10	200	0.5	0.2	15
GLZ22A	22A	22	20.15	21.20	30	5.0	200	0.5	0.2	17
GLZ22B	22B	22	20.64	21.71	30	5.0	200	0.5	0.2	17
GLZ22C	22C	22	21.08	22.17	30	5.0	200	0.5	0.2	17
GLZ22D	22D	22	21.52	22.63	30	5.0	200	0.5	0.2	17
GLZ24A	24A	24	22.05	23.18	35	5.0	200	0.5	0.2	19
GLZ24B	24B	24	22.61	23.77	35	5.0	200	0.5	0.2	19
GLZ24C	24C	24	23.12	24.31	35	5.0	200	0.5	0.2	19
GLZ24D	24D	24	23.63	24.85	35	5.0	200	0.5	0.2	19
GLZ27A	27A	27	24.26	25.52	45	5.0	250	0.5	0.2	21
GLZ27B	27B	27	24.97	26.26	45	5.0	250	0.5	0.2	21
GLZ27C	27C	27	25.63	26.95	45	5.0	250	0.5	0.2	21
GLZ27D	27D	27	26.29	27.64	45	5.0	250	0.5	0.2	21
GLZ30A	30A	30	26.99	28.39	55	5.0	250	0.5	0.2	23
GLZ30B	30B	30	27.70	29.13	55	5.0	250	0.5	0.2	23
GLZ30C	30C	30	28.36	29.82	55	5.0	250	0.5	0.2	23
GLZ30D	30C	30	29.02	30.51	55	5.0	250	0.5	0.2	23
GLZ33A	33A	33	29.68	31.22	65	5.0	250	0.5	0.2	25
GLZ33B	33B	33	30.32	31.88	65	5.0	250	0.5	0.2	25
GLZ33C	33C	33	30.90	32.50	65	5.0	250	0.5	0.2	25
GLZ33D	33D	33	31.49	33.11	65	5.0	250	0.5	0.2	25
GLZ36A	36A	36	32.14	33.79	75	5.0	250	0.5	0.2	27
GLZ36B	36B	36	32.79	34.49	75	5.0	250	0.5	0.2	27
GLZ36C	36C	36	33.40	35.13	75	5.0	250	0.5	0.2	27
GLZ36D	36D	36	34.01	35.77	75	5.0	250	0.5	0.2	27
GLZ39A	39A	39	34.68	36.47	85	5.0	250	0.5	0.2	30
GLZ39B	39B	39	35.36	37.19	85	5.0	250	0.5	0.2	30
GLZ39C	39C	39	36.00	37.85	85	5.0	250	0.5	0.2	30
GLZ39D	39D	39	36.63	38.52	85	5.0	250	0.5	0.2	30
GLZ41	41	41	37.00	41.00	90	5.0	-	-	0.2	30
GLZ43	43	43	40.00	45.00	90	5.0	-	-	0.2	33
GLZ47	47	47	44.00	49.00	90	5.0	-	-	0.2	36
GLZ51	51	51	48.00	54.00	110	5.0	-	-	0.2	39
GLZ56	56	56	53.00	60.00	110	5.0	-	-	0.2	43

Note: 1. Measured with pulses t_p = 1ms.
2. f = 1KHz

MARKING INFORMATION



Cathode = Polarity Band
xx = Device Code, See Table 1

RECOMMENDED FOOTPRINT

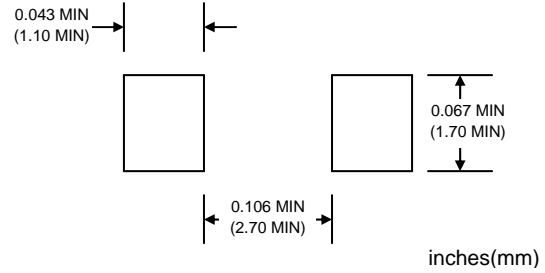

PACKAGING INFORMATION

TAPE & REEL

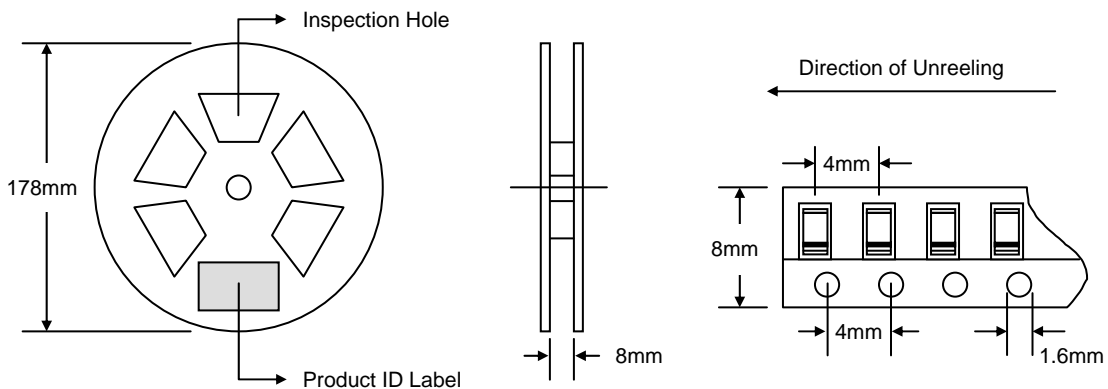

Reel Diameter (mm)	Quantity (PCS)	Inner Box Size L x W x H (mm)	Quantity (PCS)	Carton Size L x W x H (mm)	Quantity (PCS)	Approx. Gross Weight (KG)
178	2,500	185 x 120 x 185	25,000	400 x 273 x 415	200,000	13.5

Note: 1. Anti-static plastic reel, white or water clear or blue color. Inspection hole might be varied in different alignment.
2. Components are packed in accordance with EIA standard 481-1 and 481-2.

ORDERING INFORMATION

Product No.	Package Type	Shipping Quantity
GLZxx-T1	MiniMELF	2500/Tape & Reel

1. Shipping quantity given is for minimum packing quantity only. For minimum order quantity, please consult the Sales Department.
2. **To order RoHS / Lead Free version (with Lead Free finish), add "-LF" suffix to part number above. For example, GLZ2.0A-T1-LF.**

WON-TOP ELECTRONICS and  are registered trademarks of Won-Top Electronics Co., Ltd (WTE). WTE has checked all information carefully and believes it to be correct and accurate. However, WTE cannot assume any responsibility for inaccuracies. Furthermore, this information does not give the purchaser of semiconductor devices any license under patent rights to manufacturer. WTE reserves the right to change any or all information herein without further notice.

WARNING: DO NOT USE IN LIFE SUPPORT EQUIPMENT. WTE power semiconductor products are not authorized for use as critical components in life support devices or systems without the express written approval.

Won-Top Electronics Co., Ltd.

No. 44 Yu Kang North 3rd Road,

Chine Chen Dist., Kaohsiung 806, Taiwan

Phone: 886-7-822-5408 or 886-7-822-5410

Fax: 886-7-822-5417

Email: sales@wontop.com

Internet: <http://www.wontop.com>

We power your everyday.