



N-Channel Enhancement Mode Field Effect Transistor

PRODUCT SUMMARY

V _{DSS}	I _D	R _{DS(ON)} (mΩ) Max
40V	1.2A	350 @ V _{GS} =10V
		500 @ V _{GS} =4.5V

FEATURES

- Super high dense cell design for low R_{DS(ON)}.
- Rugged and reliable.
- Surface Mount Package.
- ESD Protected.

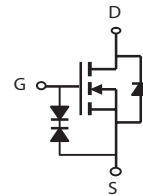
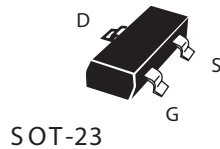

ABSOLUTE MAXIMUM RATINGS (T_A=25°C unless otherwise noted)

Symbol	Parameter	Limit	Units
V _{DS}	Drain-Source Voltage	40	V
V _{GS}	Gate-Source Voltage	±20	V
I _D	Drain Current-Continuous ^a	T _A =25°C	1.2
		T _A =70°C	0.96
I _{DM}	-Pulsed ^b	4.5	A
P _D	Maximum Power Dissipation	T _A =25°C	1.25
		T _A =70°C	0.8
T _J , T _{STG}	Operating Junction and Storage Temperature Range	-55 to 150	°C

THERMAL CHARACTERISTICS

Symbol	Parameter	Limit	Units
R _{θJA}	Thermal Resistance, Junction-to-Ambient	100	°C/W

STS400

Ver 1.1

ELECTRICAL CHARACTERISTICS (TA=25°C unless otherwise noted)

Symbol	Parameter	Conditions	Min	Typ	Max	Units
OFF CHARACTERISTICS						
BV _{DSS}	Drain-Source Breakdown Voltage	V _{GS} =0V , I _D =250uA	40			V
I _{DSS}	Zero Gate Voltage Drain Current	V _{DS} =32V , V _{GS} =0V			1	uA
I _{GSS}	Gate-Body Leakage Current	V _{GS} = ±20V , V _{BS} =0V			±10	uA
ON CHARACTERISTICS						
V _{GS(th)}	Gate Threshold Voltage	V _{DS} =V _{GS} , I _D =250uA	0.8	1.3	2.0	V
R _{DS(ON)}	Drain-Source On-State Resistance	V _{GS} =10V , I _D =0.6A		250	350	m ohm
		V _{GS} =4.5V , I _D =0.5A		350	500	m ohm
g _{FS}	Forward Transconductance	V _{DS} =5V , I _D =0.6A		1.4		S
DYNAMIC CHARACTERISTICS ^c						
C _{ISS}	Input Capacitance	V _{DS} =20V, V _{GS} =0V f=1.0MHz		40		pF
C _{OSS}	Output Capacitance			17.5		pF
C _{RSS}	Reverse Transfer Capacitance			9.5		pF
SWITCHING CHARACTERISTICS ^c						
t _{D(ON)}	Turn-On Delay Time	V _{DD} =20V I _D =0.6A V _{GS} =10V R _{GEN} = 6 ohm		7.8		ns
t _r	Rise Time			11.2		ns
t _{D(OFF)}	Turn-Off Delay Time			105		ns
t _f	Fall Time			14		ns
Q _g	Total Gate Charge	V _{DS} =20V, I _D =0.6A, V _{GS} =10V		1.70		nC
		V _{DS} =20V, I _D =0.6A, V _{GS} =4.5V		1.15		nC
Q _{gs}	Gate-Source Charge	V _{DS} =20V, I _D =0.6A, V _{GS} =10V		0.42		nC
Q _{gd}	Gate-Drain Charge			0.61		nC
DRAIN-SOURCE DIODE CHARACTERISTICS AND MAXIMUM RATINGS						
V _{SD}	Diode Forward Voltage	V _{GS} =0V, I _S =1.2A		0.9	1.3	V

Notes

- Surface Mounted on FR4 Board, t ≤ 10sec.
- Pulse Test: Pulse Width ≤ 300us, Duty Cycle ≤ 2%.
- Guaranteed by design, not subject to production testing.

May,31,2012

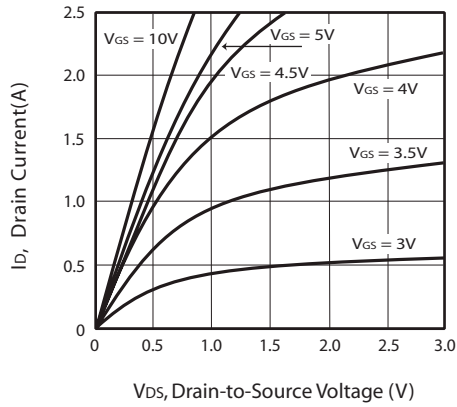

Figure 1. Output Characteristics

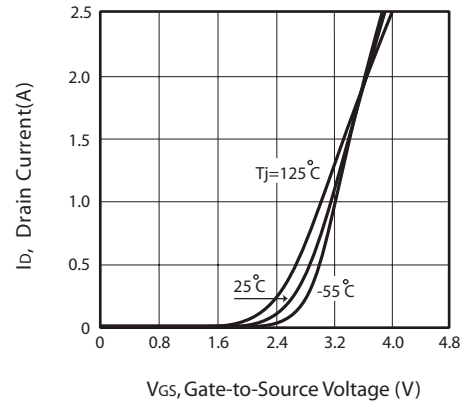

Figure 2. Transfer Characteristics

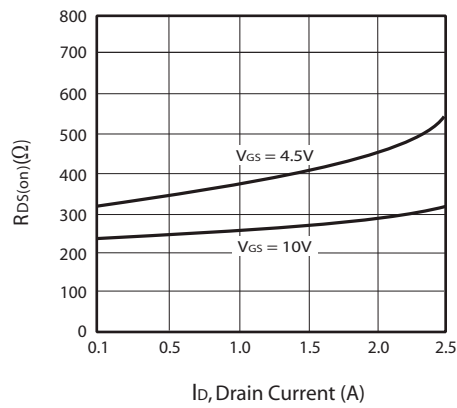

Figure 3. On-Resistance vs. Drain Current and Gate Voltage

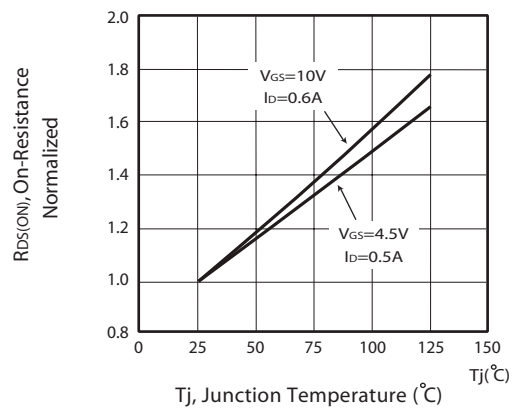

Figure 4. On-Resistance Variation with Drain Current and Temperature

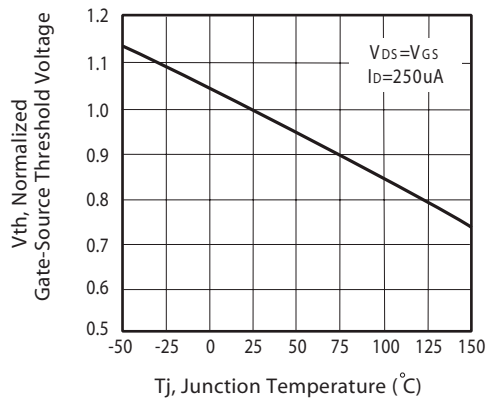

Figure 5. Gate Threshold Variation with Temperature

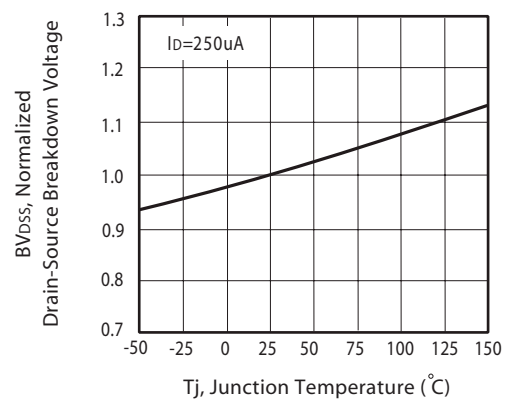

Figure 6. Breakdown Voltage Variation with Temperature

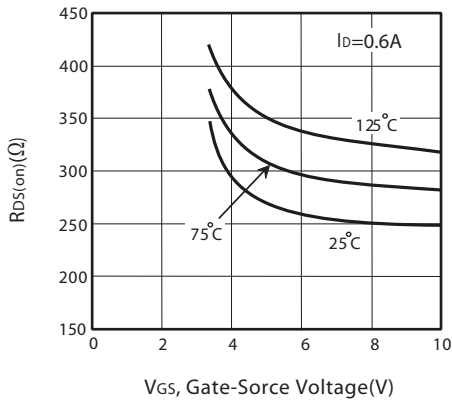

Figure 7. On-Resistance vs. Gate-Source Voltage

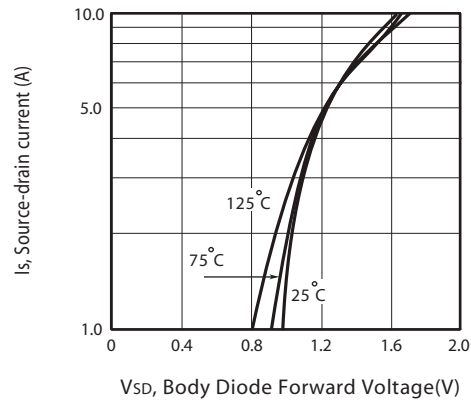

Figure 8. Body Diode Forward Voltage Variation with Source Current

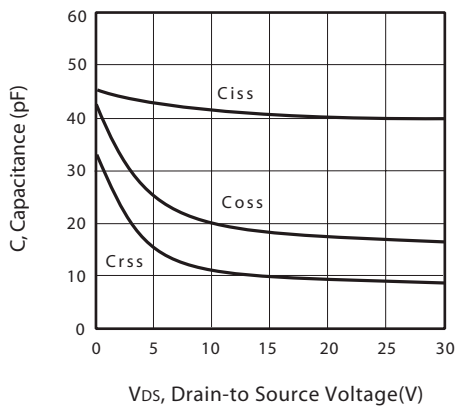

Figure 9. Capacitance

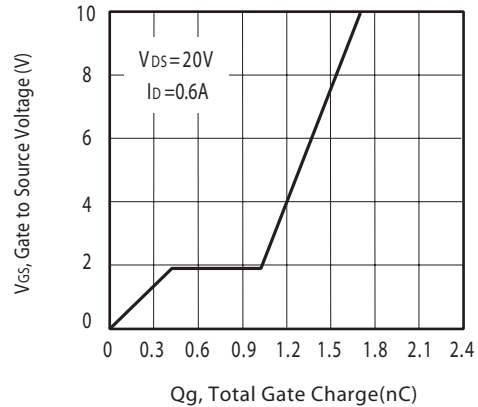

Figure 10. Gate Charge

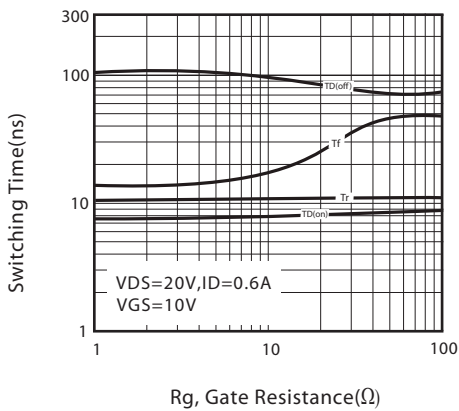

Figure 11. switching characteristics

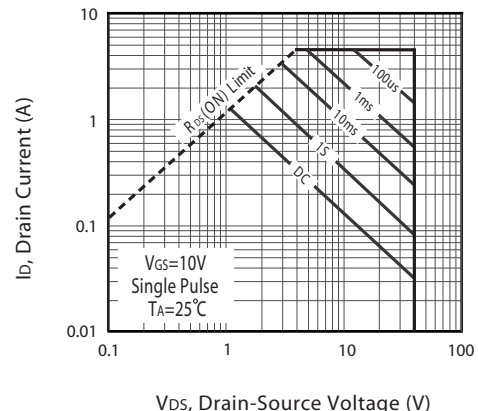

Figure 12. Maximum Safe Operating Area

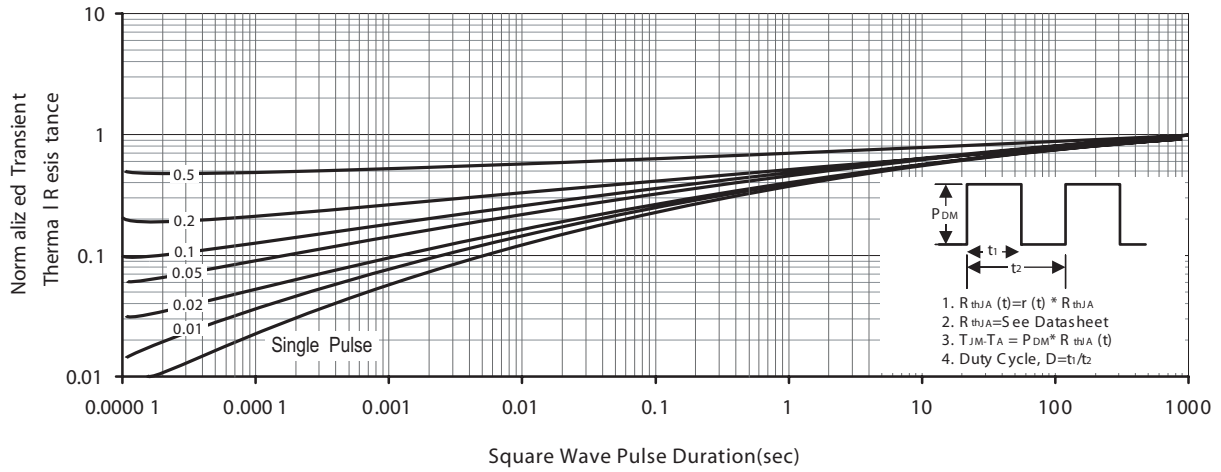
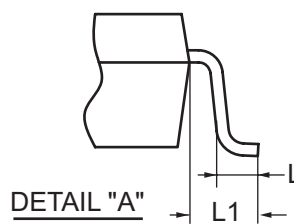
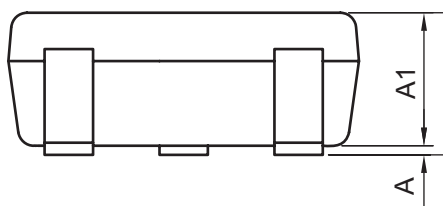
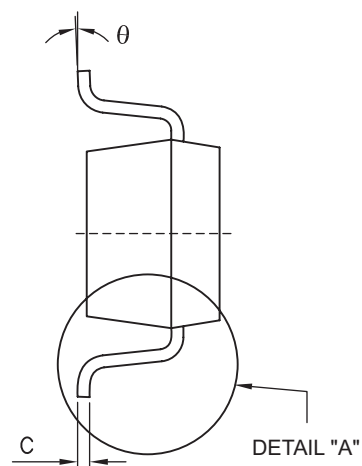
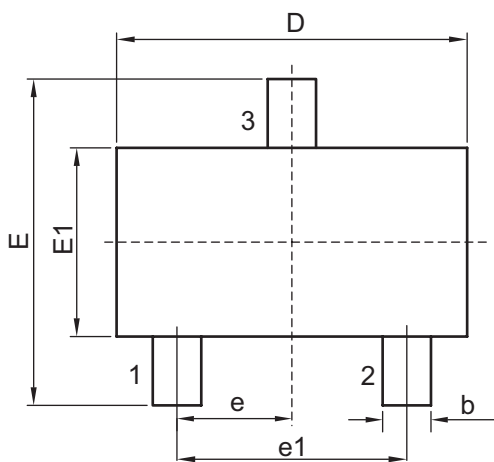

Figure 13. Normalized Thermal Transient Impedance Curve

PACKAGE OUTLINE DIMENSIONS

SOT 23



SYMBOLS	MILLIMETERS		INCHES	
	MIN	MAX	MIN	MAX
D	2.700	3.100	0.106	0.122
E	2.200	3.000	0.087	0.118
E1	1.200	1.700	0.047	0.067
e	0.850	1.150	0.033	0.045
e1	1.800	2.100	0.071	0.083
b	0.300	0.510	0.019	0.020
C	0.080	0.200	0.003	0.008
A	0.000	0.150	0.000	0.006
A1	0.887	1.300	0.035	0.051
L	0.450 REF.		0.018 REF.	
L1	0.600 REF.		0.024 REF.	
θ	0°	10°	0°	10°

SOT23 Tape and Reel Data

SOT23-3L Carrier Tape

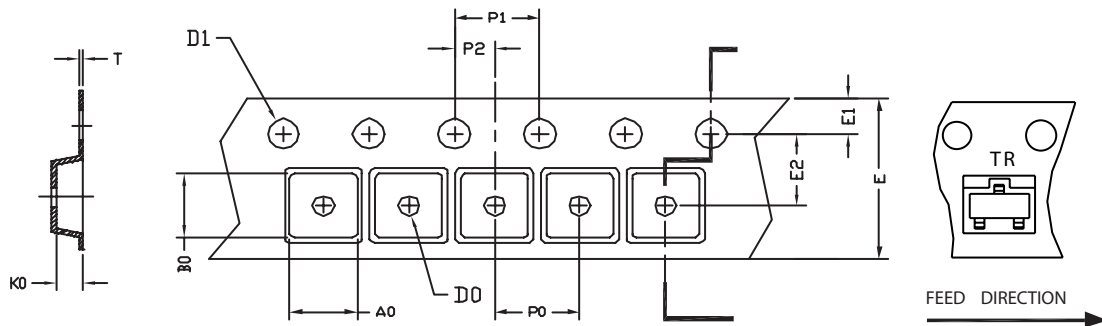

UNIT:mm

PACKAGE	A0	B0	K0	D0	D1	E	E1	E2	P0	P1	P2	T
SOT23-3L	3.15 ± 0.10	2.77 ± 0.10	1.22 ± 0.10	ϕ 1.00 $+0.05$	ϕ 1.50 $+0.10$	8.00 $+0.30$ -0.10	1.75 ± 0.10	3.50 ± 0.05	4.00 ± 0.10	4.00 ± 0.10	2.00 ± 0.05	0.22 ± 0.04

SOT23-3L Reel

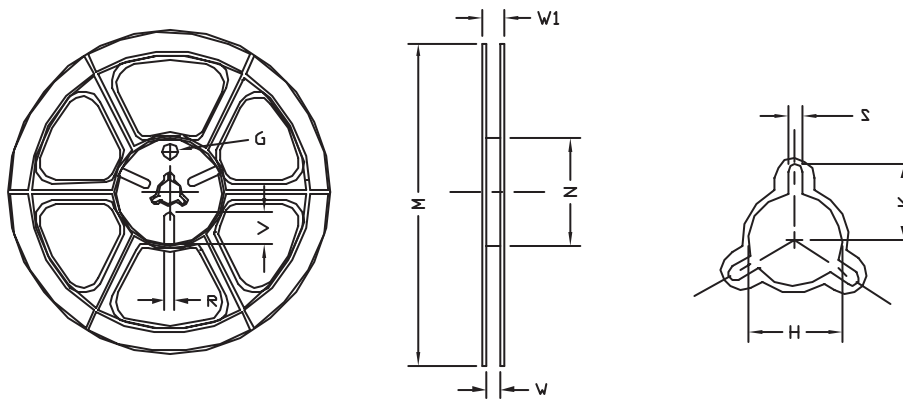

UNIT:mm

TAPE SIZE	REEL SIZE	M	N	W	W1	H	K	S	G	R	V
8mm	ϕ 178	ϕ 178 ± 1	ϕ 60 ± 1	9.00 ± 0.5	12.00 ± 0.5	ϕ 13.5 ± 0.5	10.5	2.00 ± 0.5	ϕ 10.0	5.00	18.00