



## P-Channel Enhancement Mode Field Effect Transistor

### PRODUCT SUMMARY

VDSS	ID	RDS(ON) (mΩ) Max
-60V	-2.5A	180 @ VGS=-10V
		240 @ VGS=-4.5V

### FEATURES

- Super high dense cell design for low RDS(ON).
- Rugged and reliable.
- SOT-223 package.

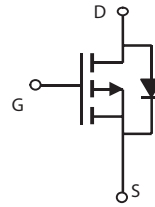
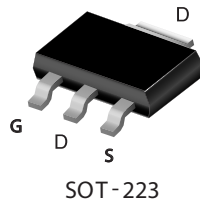

### ABSOLUTE MAXIMUM RATINGS (TA=25°C unless otherwise noted)

Symbol	Parameter	Limit	Units
V <sub>DS</sub>	Drain-Source Voltage	-60	V
V <sub>GS</sub>	Gate-Source Voltage	±20	V
I <sub>D</sub>	Drain Current-Continuous <sup>a</sup>	T <sub>A</sub> =25°C	-2.5
		T <sub>A</sub> =70°C	-2.0
I <sub>DM</sub>	-Pulsed <sup>b</sup>	-20	A
P <sub>D</sub>	Maximum Power Dissipation <sup>a</sup>	T <sub>A</sub> =25°C	2.08
		T <sub>A</sub> =70°C	1.33
T <sub>J</sub> , T <sub>STG</sub>	Operating Junction and Storage Temperature Range	-55 to 150	°C

### THERMAL CHARACTERISTICS

Symbol	Parameter	Limit	Units
R <sub>θJA</sub>	Thermal Resistance, Junction-to-Ambient <sup>a</sup>	60	°C/W

# STT6603

Ver 1.0

## ELECTRICAL CHARACTERISTICS (TA=25°C unless otherwise noted)

Symbol	Parameter	Conditions	Min	Typ	Max	Units
<b>OFF CHARACTERISTICS</b>						
BV <sub>DSS</sub>	Drain-Source Breakdown Voltage	V <sub>GS</sub> =0V , I <sub>D</sub> =-250uA	-60			V
I <sub>DSS</sub>	Zero Gate Voltage Drain Current	V <sub>DS</sub> =-48V , V <sub>GS</sub> =0V			-1	uA
I <sub>GSS</sub>	Gate-Body Leakage Current	V <sub>GS</sub> = ±20V , V <sub>DS</sub> =0V			±100	nA
<b>ON CHARACTERISTICS</b>						
V <sub>GS(th)</sub>	Gate Threshold Voltage	V <sub>DS</sub> =V <sub>GS</sub> , I <sub>D</sub> =-250uA	-1.0	-2.0	-3	V
R <sub>DS(ON)</sub>	Drain-Source On-State Resistance	V <sub>GS</sub> =-10V , I <sub>D</sub> =-2.5A		90	180	m ohm
		V <sub>GS</sub> =-4.5V , I <sub>D</sub> =-2.2A		120	240	m ohm
g <sub>FS</sub>	Forward Transconductance	V <sub>DS</sub> =-10V , I <sub>D</sub> =-2.5A		6.4		S
<b>DYNAMIC CHARACTERISTICS <sup>c</sup></b>						
C <sub>ISS</sub>	Input Capacitance	V <sub>DS</sub> =-30V, V <sub>GS</sub> =0V f=1.0MHz		780		pF
C <sub>OSS</sub>	Output Capacitance			65		pF
C <sub>RSS</sub>	Reverse Transfer Capacitance			40		pF
<b>SWITCHING CHARACTERISTICS <sup>c</sup></b>						
t <sub>D(ON)</sub>	Turn-On Delay Time	V <sub>DD</sub> =-30V I <sub>D</sub> =-1A V <sub>GS</sub> =-10V R <sub>GEN</sub> =6 ohm		12.5		ns
t <sub>r</sub>	Rise Time			13		ns
t <sub>D(OFF)</sub>	Turn-Off Delay Time			59.5		ns
t <sub>f</sub>	Fall Time			12		ns
Q <sub>g</sub>	Total Gate Charge	V <sub>DS</sub> =-30V, I <sub>D</sub> =-2.5A, V <sub>GS</sub> =-10V		13.5		nC
		V <sub>DS</sub> =-30V, I <sub>D</sub> =-2.5A, V <sub>GS</sub> =-4.5V		6.8		nC
Q <sub>gs</sub>	Gate-Source Charge	V <sub>DS</sub> =-30V, I <sub>D</sub> =-2.5A, V <sub>GS</sub> =-10V		1.8		nC
Q <sub>gd</sub>	Gate-Drain Charge			2.6		nC
<b>DRAIN-SOURCE DIODE CHARACTERISTICS AND MAXIMUM RATINGS</b>						
I <sub>S</sub>	Maximum Continuous Drain-Source Diode Forward Current				-2.0	A
V <sub>SD</sub>	Diode Forward Voltage <sup>b</sup>	V <sub>GS</sub> =0V, I <sub>S</sub> =-2A		-0.8	-1.2	V

### Notes

- Surface Mounted on FR4 Board, t ≤ 10sec.
- Pulse Test: Pulse Width ≤ 300us, Duty Cycle ≤ 2%.
- Guaranteed by design, not subject to production testing.

Nov, 17, 2008

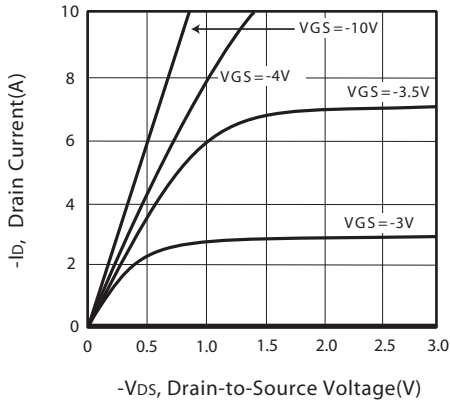

Figure 1. Output Characteristics

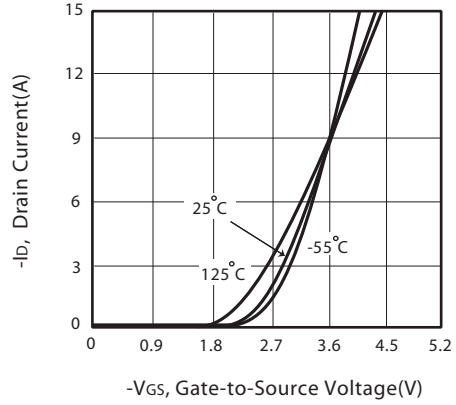

Figure 2. Transfer Characteristics

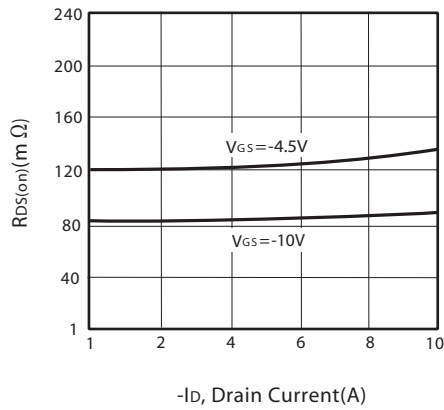

Figure 3. On-Resistance vs. Drain Current and Gate Voltage

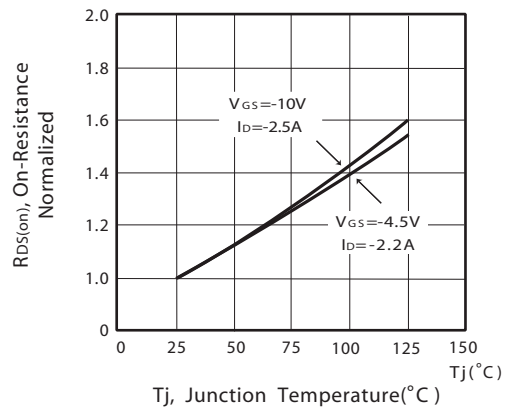

Figure 4. On-Resistance Variation with Drain Current and Temperature

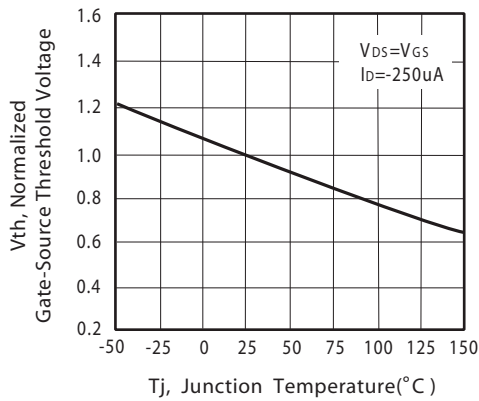

Figure 5. Gate Threshold Variation with Temperature

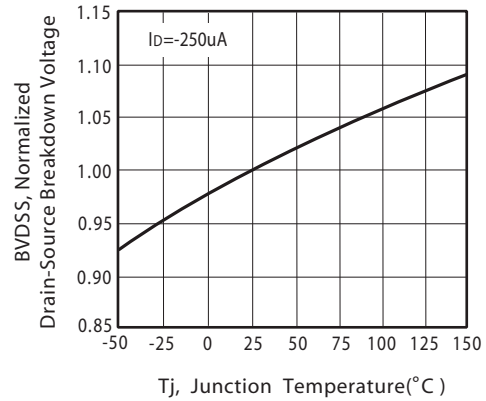

Figure 6. Breakdown Voltage Variation with Temperature

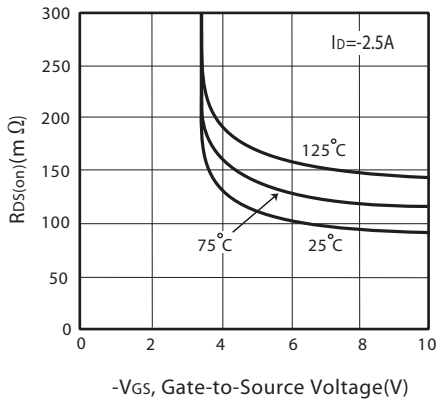

Figure 7. On-Resistance vs. Gate-Source Voltage

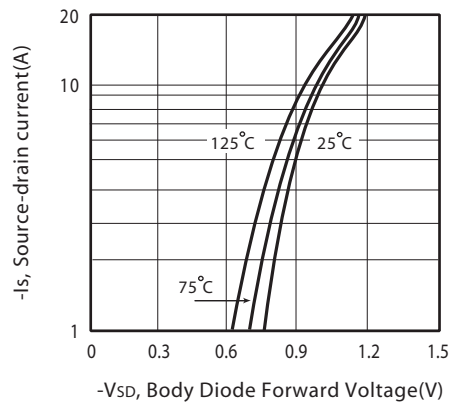

Figure 8. Body Diode Forward Voltage Variation with Source Current

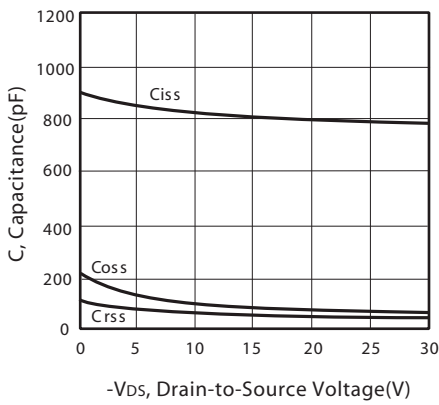

Figure 9. Capacitance

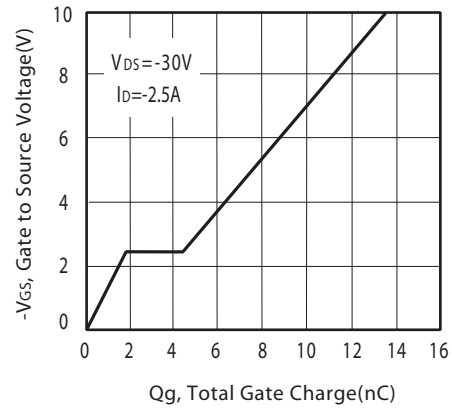

Figure 10. Gate Charge

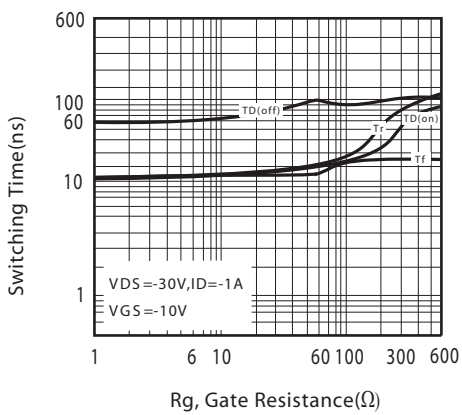

Figure 11. switching characteristics

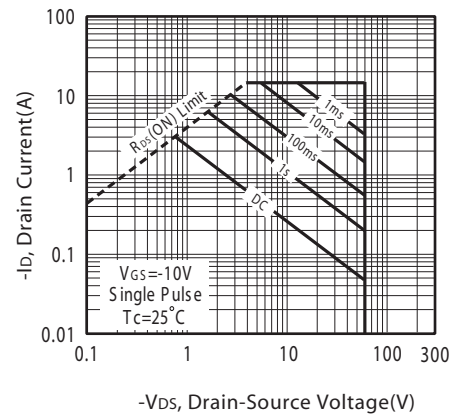

Figure 12. Maximum Safe Operating Area

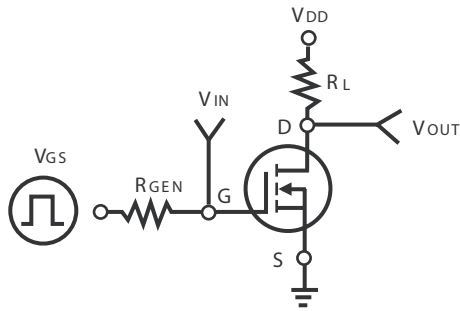

Figure 13. Switching Test Circuit

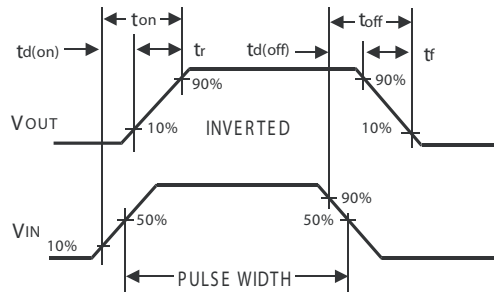

Figure 14. Switching Waveforms

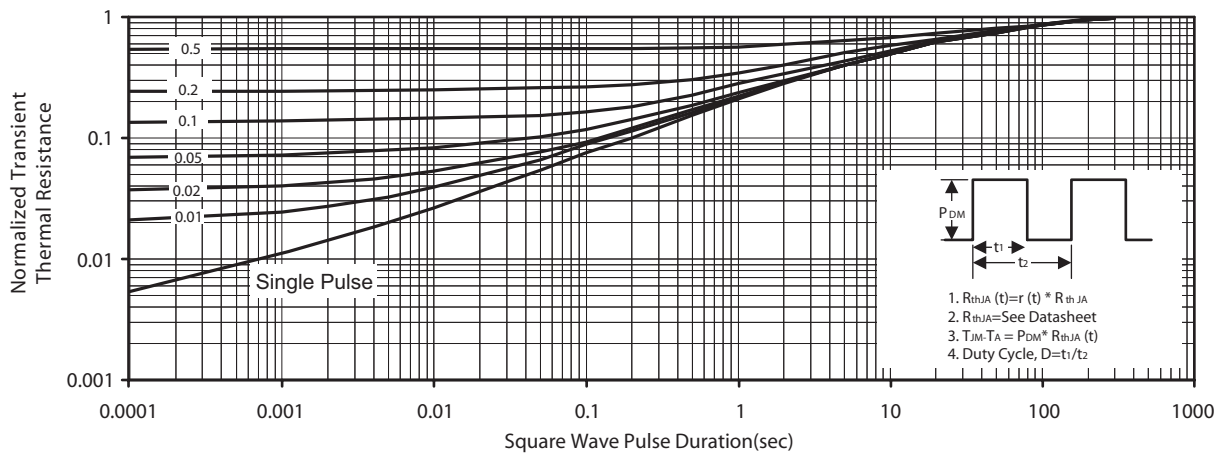
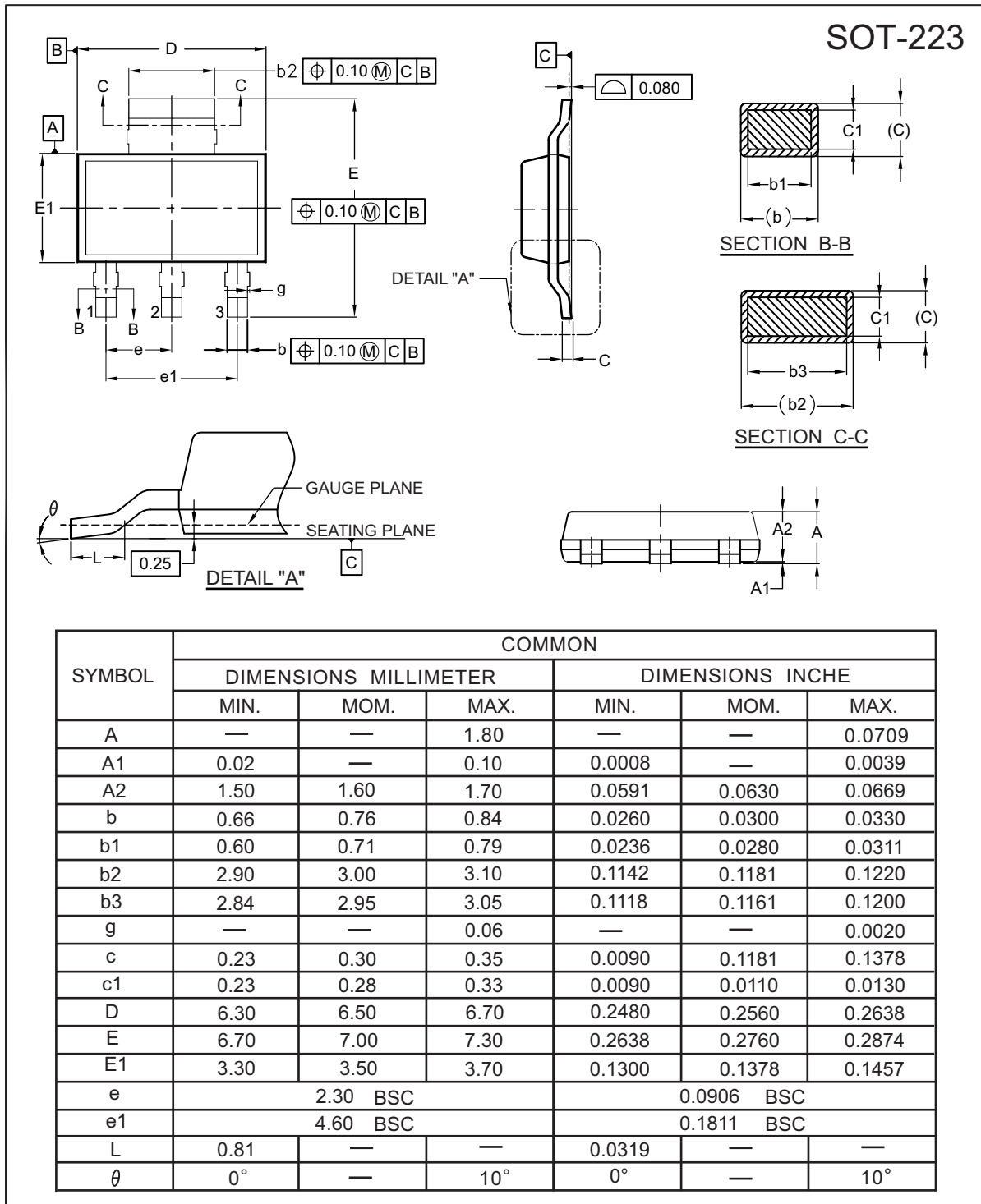

Figure 13. Normalized Thermal Transient Impedance Curve

# STT6603

Ver 1.0



Nov,17,2008

## SOT-223 Tape and Reel Data

### SOT-223 Carrier Tape

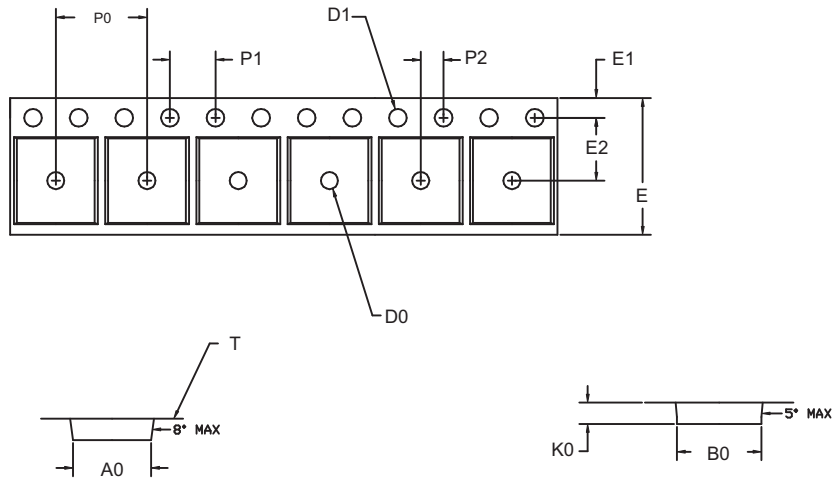

unit:mm

PACKAGE	A0	B0	K0	D0	D1	E	E1	E2	P0	P1	P2	T
---	6.83 ±0.1	7.42 ±0.1	1.88 ±0.1	1.50 + 0.25	1.60 + 0.1	12.0 + 0.3 - 0.1	1.75 ±0.1	5.50 ±0.5	8.0 ±0.1	4.00 ±0.1	2.00 ±0.05	0.292 ±0.02

### SOT-223 Reel

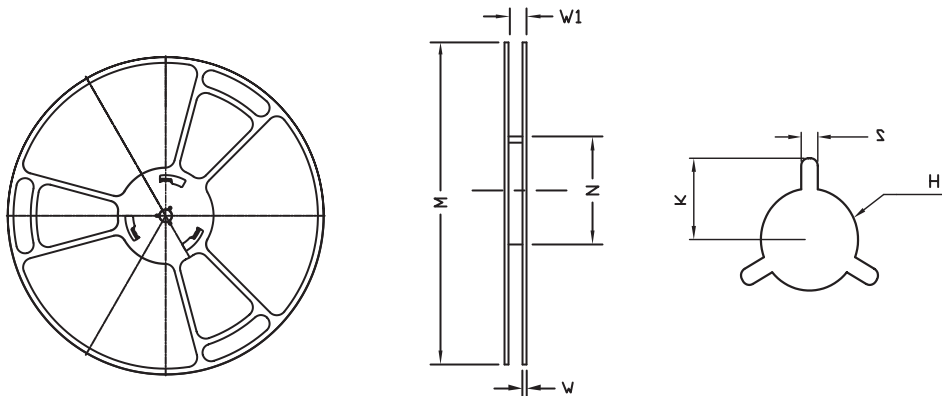

UNIT:mm

REEL SIZE	M	N	W	W1	H	K	S	G	R	V
φ 330 ± 0.5	---	φ 97.0 ± 1.0	2.2	13.0 + 1.5	φ 13.0 + 0.5 - 0.2	10.6	2.0 ±0.5	---	---	---