

用途：用于高频、低压、大电流整流二极管、续流二极管、保护二极管。

Purpose: For use in low voltage, high frequency inverters, free wheeling, and polarity protection applications.

特点：损耗低，效率高。

Features: Low power loss, high efficiency.

极限参数/Absolute maximum ratings per leg (Ta=25°C)

参数符号 Symbol	数值 Rating	单位 Unit
V_{RRM} V_{RWM}	40	V
V_R	40	V
$I_{F(AV)}$	10	A
I_{FSM}	100	A
T_j	-65~150	°C
T_{stg}	-65~150	°C

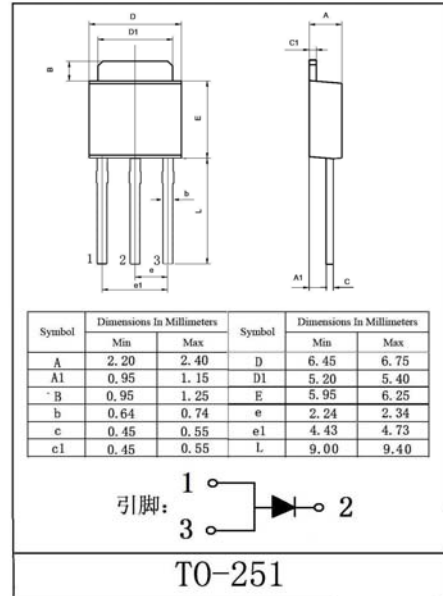

电性能参数/Electrical characteristics per leg (Ta=25°C)

参数符号 Symbol	测试条件 Test condition	数值 Rating			单位 Unit
		最小值 Min	典型值 Typ	最大值 Max	
V_R	$I_R = 1mA$	40			V
V_{FM}	$I_F = 8A (T_c = 25^\circ C)$		0.45	0.49	V
	$I_F = 8A (T_c = 125^\circ C)$			0.41	V
	$I_F = 10A (T_c = 25^\circ C)$		0.47	0.51	V
I_{RM}	$V_R = 35V (T_c = 25^\circ C)$		0.1	0.3	mA
	$V_R = 35V (T_c = 125^\circ C)$		12.5	25	mA
dv/dt				10000	V/μs

