

MJE13003VG5 (3DD13003VG5)

硅 NPN 半导体三极管/SILICON NPN TRANSISTOR

用途:主要用于节能灯、日光灯电子镇流器及其它开关、振荡电路。

Purpose: High frequency electronic lighting ballast applications, converters, inverters, switching regulators, etc.

极限参数/Absolute maximum ratings(Ta=25°C)

参数符号 Symbol	数值 Rating	单位 Unit
V_{CBO}	400	V
V_{CEO}	200	V
V_{EBO}	9.0	V
I_C	1.5	A
$P_C(T_a=25^\circ C)$	1.25	W
$P_C(T_c=25^\circ C)$	30	W
T_j	150	°C
T_{stg}	-55~150	°C

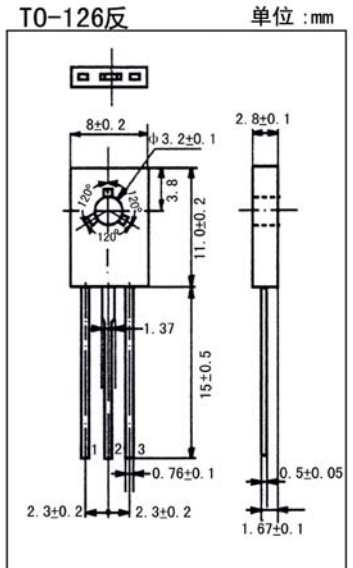
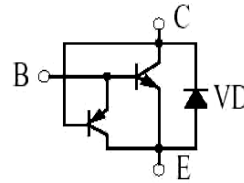

引脚: 1. B 2. C 3. E

电性能参数/Electrical characteristics(Ta=25°C)

参数符号 Symbol	测试条件 Test condition		数值 Rating			单位 Unit
			最小值 Min	典型值 Typ	最大值 Max	
V_{CBO}	$I_C=1mA$	$I_E=0$	400			V
V_{CEO}	$I_C=10mA$	$I_B=0$	200			V
V_{EBO}	$I_E=1mA$	$I_C=0$	9.0			V
I_{CBO}	$V_{CB}=400V$	$I_E=0$			0.1	mA
I_{CEO}	$V_{CE}=200V$	$I_B=0$			0.1	mA
I_{EBO}	$V_{EB}=9.0V$	$I_C=0$			0.1	mA
h_{FE}	$V_{CE}=5.0V$	$I_C=200mA$	10		40	
$V_{CE(sat)}$	$I_C=1A$	$I_B=250mA$			0.6	V
$V_{BE(sat)}$	$I_C=1A$	$I_B=250mA$			1.2	V
f_T	$V_{CE}=10V$	$I_C=200mA$	$f=1.0MHz$	5.0		MHz
t_f	$V_{CE}=5V$	$I_C=100mA$			0.6	μs
t_s	(UI9600)				4.0	μs

MJE13003VG5 (3DD13003VG5)

