

用途：主要用于节能灯、日光灯电子镇流器及其它开关、振荡电路。

Purpose: High frequency electronic lighting ballast applications, converters, inverters, switching regulators, etc.

极限参数/Absolute maximum ratings ( $T_a=25^\circ\text{C}$ )

参数符号 Symbol	数值 Rating	单位 Unit
$V_{CB0}$	700	V
$V_{CE0}$	400	V
$V_{EB0}$	9.0	V
$I_C$	2.0	A
$P_C (T_a=25^\circ\text{C})$	1.25	W
$P_C (T_c=25^\circ\text{C})$	50	W
$T_j$	150	$^\circ\text{C}$
$T_{stg}$	-55~150	$^\circ\text{C}$

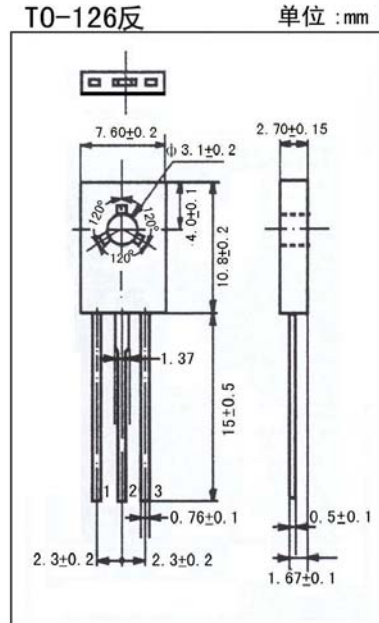

引脚: 1. B 2. C 3. E

电性能参数/Electrical characteristics ( $T_a=25^\circ\text{C}$ )

参数符号 Symbol	测试条件 Test condition		数值 Rating			单位 Unit
			最小值 Min	典型值 Typ	最大值 Max	
$V_{CB0}$	$I_C=1\text{mA}$	$I_E=0$	700			V
$V_{CE0}$	$I_C=10\text{mA}$	$I_B=0$	400			V
$V_{EB0}$	$I_E=1\text{mA}$	$I_C=0$	9.0			V
$I_{CB0}$	$V_{CB}=700\text{V}$	$I_E=0$			0.1	mA
$I_{CE0}$	$V_{CE}=400\text{V}$	$I_B=0$			0.1	mA
$I_{EB0}$	$V_{EB}=9.0\text{V}$	$I_C=0$			0.1	mA
$h_{FE}$	$V_{CE}=5.0\text{V}$	$I_C=0.5\text{A}$	10		40	
$V_{CE(sat)}$	$I_C=1.0\text{A}$	$I_B=0.25\text{A}$			0.8	V
$V_{BE(sat)}$	$I_C=1.0\text{A}$	$I_B=0.5\text{A}$			1.2	V
$f_T$	$V_{CE}=10\text{V}$	$I_C=0.1\text{A}$	$f=1.0\text{MHz}$	5.0		MHz
$T_{stg}$	$V_{CE}=5\text{V}$	$I_C=0.25\text{A}$			6	$\mu\text{s}$
$T_{off}$	(UI9600)				0.8	$\mu\text{s}$

