

用途：主要用于节能灯、日光灯电子镇流器及其它开关、振荡电路。

Purpose: High frequency electronic lighting ballast applications, converters, inverters, switching regulators, etc.

极限参数/Absolute maximum ratings(Ta=25°C)

参数符号 Symbol	数值 Rating	单位 Unit
V_{CB0}	700	V
V_{CE0}	400	V
V_{EB0}	9.0	V
I_C	1.8	A
$P_C(Ta=25^\circ C)$	2.0	W
$P_C(Tc=25^\circ C)$	50	W
T_j	150	°C
T_{stg}	-55~150	°C

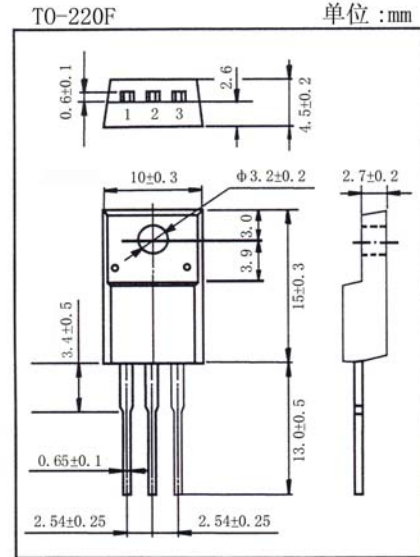

引脚： 1. B 2. C 3. E

电性能参数/Electrical characteristics(Ta=25°C)

参数符号 Symbol	测试条件 Test condition		数值 Rating			单位 Unit
			最小值 Min	典型值 Typ	最大值 Max	
V_{CB0}	$I_C=1mA$	$I_E=0$	700			V
V_{CE0}	$I_C=10mA$	$I_B=0$	400			V
V_{EB0}	$I_E=1mA$	$I_C=0$	9.0			V
I_{CB0}	$V_{CB}=700V$	$I_E=0$			0.1	mA
I_{CE0}	$V_{CE}=400V$	$I_B=0$			0.1	mA
I_{EB0}	$V_{EB}=9.0V$	$I_C=0$			0.1	mA
h_{FE}	$V_{CE}=5.0V$	$I_C=0.5A$	10		40	
$V_{CE(sat)}$	$I_C=1.0A$	$I_B=0.25A$			0.8	V
$V_{BE(sat)}$	$I_C=1.0A$	$I_B=0.5A$			1.2	V
f_T	$V_{CE}=10V$	$I_C=0.1A$	$f=1.0MHz$	5.0		MHz
t_f	$V_{CE}=5V$	$I_C=0.25A$			0.8	μs
t_s	(UI9600)				4.0	μs

MJE13003M8 (3DD13003M8)

