

用途：主要用于节能灯、日光灯电子镇流器及其它开关、振荡电路。

Purpose: High frequency electronic lighting ballast applications, converters, inverters, switching regulators, etc.

极限参数/Absolute maximum ratings ($T_a=25^\circ\text{C}$)

参数符号 Symbol	数值 Rating	单位 Unit
V_{CB0}	700	V
V_{CE0}	400	V
V_{EB0}	9.0	V
I_C	1.8	A
$P_C (T_a=25^\circ\text{C})$	1.25	W
$P_C (T_c=25^\circ\text{C})$	50	W
T_j	150	$^\circ\text{C}$
T_{stg}	-55~150	$^\circ\text{C}$

T0-126F反 单位: mm

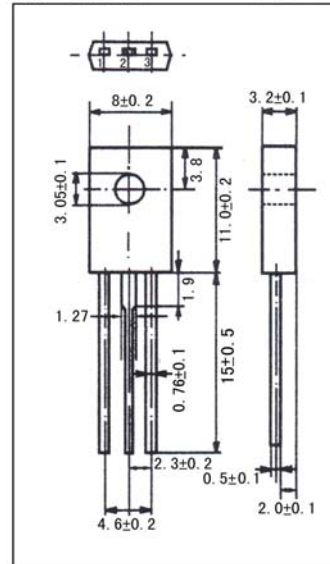

引脚： 1.B 2.C 3.E

电性能参数/Electrical characteristics ($T_a=25^\circ\text{C}$)

参数符号 Symbol	测试条件 Test condition	数值 Rating			单位 Unit
		最小值 Min	典型值 Typ	最大值 Max	
V_{CB0}	$I_C=1\text{mA}$ $I_E=0$	700			V
V_{CE0}	$I_C=10\text{mA}$ $I_B=0$	400			V
V_{EB0}	$I_E=1\text{mA}$ $I_C=0$	9.0			V
I_{CB0}	$V_{CB}=700\text{V}$ $I_E=0$			0.1	mA
I_{CE0}	$V_{CE}=400\text{V}$ $I_B=0$			0.1	mA
I_{EB0}	$V_{EB}=9.0\text{V}$ $I_C=0$			0.1	mA
h_{FE}	$V_{CE}=5.0\text{V}$ $I_C=0.5\text{A}$	10		40	
$V_{CE(sat)}$	$I_C=1.0\text{A}$ $I_B=0.25\text{A}$			0.8	V
$V_{BE(sat)}$	$I_C=1.0\text{A}$ $I_B=0.5\text{A}$			1.2	V
f_T	$V_{CE}=10\text{V}$ $I_C=0.1\text{A}$ $f=1.0\text{MHz}$	5.0			MHz
t_f	$V_{CE}=5\text{V}$ $I_C=0.25\text{A}$			0.8	μs
t_s	(UI9600)			4.0	μs

MJE13003M6 (3DD13003M6)

