

用途：主要用于节能灯、日光灯电子镇流器及其它开关、振荡电路。

Purpose: High frequency electronic lighting ballast applications, converters, inverters, switching regulators, etc.

极限参数/Absolute maximum ratings($T_a=25^\circ\text{C}$)

参数符号 Symbol	数值 Rating	单位 Unit
V_{CBO}	700	V
V_{CEO}	450	V
V_{EBO}	9	V
I_{C}	1.8	A
$P_{\text{C}}(T_a=25^\circ\text{C})$	1.25	W
$P_{\text{C}}(T_c=25^\circ\text{C})$	50	W
T_{j}	150	$^\circ\text{C}$
T_{stg}	-55~150	$^\circ\text{C}$

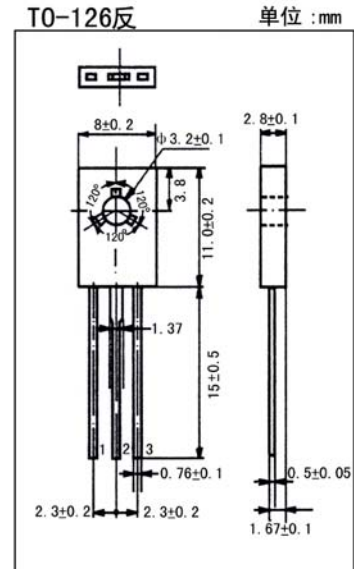

引脚: 1. B 2. C 3. E

电性能参数/Electrical characteristics($T_a=25^\circ\text{C}$)

参数符号 Symbol	测试条件 Test condition		数值 Rating			单位 Unit
			最小值 Min	典型值 Typ	最大值 Max	
V_{CBO}	$I_{\text{C}}=1\text{mA}$	$I_{\text{E}}=0$	700			V
V_{CEO}	$I_{\text{C}}=10\text{mA}$	$I_{\text{B}}=0$	450			V
V_{EBO}	$I_{\text{E}}=1\text{mA}$	$I_{\text{C}}=0$	9			V
I_{CBO}	$V_{\text{CB}}=700\text{V}$	$I_{\text{E}}=0$			0.1	mA
I_{CEO}	$V_{\text{CE}}=450\text{V}$	$I_{\text{B}}=0$			0.1	mA
I_{EBO}	$V_{\text{EB}}=9\text{V}$	$I_{\text{C}}=0$			0.1	mA
h_{FE}	$V_{\text{CE}}=5.0\text{V}$	$I_{\text{C}}=0.5\text{A}$	10		40	
$V_{\text{CE(sat)}}$	$I_{\text{C}}=1.0\text{A}$	$I_{\text{B}}=0.25\text{A}$			0.8	V
$V_{\text{BE(sat)}}$	$I_{\text{C}}=1.0\text{A}$	$I_{\text{B}}=0.5\text{A}$			1.2	V
f_{T}	$V_{\text{CE}}=10\text{V}$	$I_{\text{C}}=0.1\text{A}$	$f=1.0\text{MHz}$	5.0		MHz
t_{s}	$V_{\text{CE}}=5\text{V}$	$I_{\text{C}}=0.25\text{A}$			4	μs
t_{f}	(UI9600)				0.8	μs

SOA (DC)

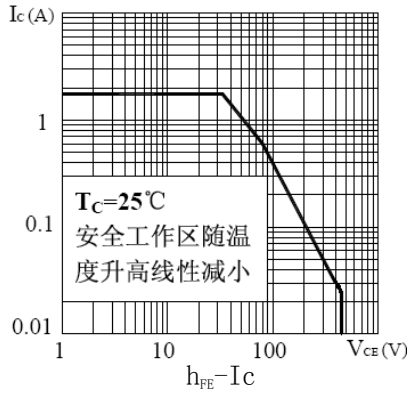

$P_c - T_c$

