

MJE13003LF5 (3DD13003LF5)

硅 NPN 半导体三极管/SILICON NPN TRANSISTOR

用途:主要用于节能灯、日光灯电子镇流器及其它开关、振荡电路。

Purpose: High frequency electronic lighting ballast applications, converters, inverters, switching regulators, etc.

极限参数/Absolute maximum ratings(Ta=25°C)

参数符号 Symbol	数值 Rating	单位 Unit
V _{CBO}	400	V
V _{CEO}	200	V
V _{EBO}	9.0	V
I _C	1.2	A
P _C (Ta=25°C)	1.25	W
P _C (T _C =25°C)	20	W
T _j	150	°C
T _{stg}	-55~150	°C

T0-126反 单位: mm

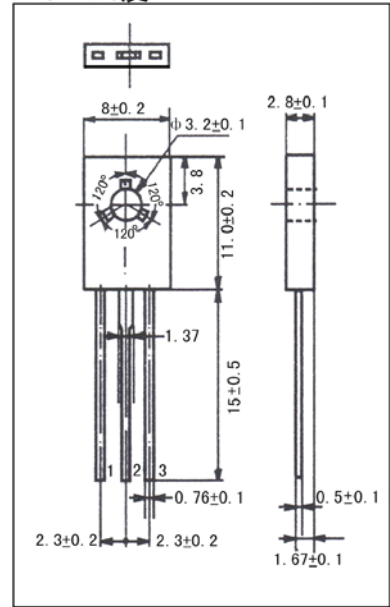

引脚: 1. B 2. C 3. E

电性能参数/Electrical characteristics(Ta=25°C)

参数符号 Symbol	测试条件 Test condition		数值 Rating			单位 Unit
			最小值 Min	典型值 Typ	最大值 Max	
V _{CBO}	I _C =1mA	I _E =0	400			V
V _{CEO}	I _C =10mA	I _B =0	200			V
V _{EBO}	I _E =1mA	I _C =0	9.0			V
I _{CBO}	V _{CB} =400V	I _E =0			0.1	mA
I _{CEO}	V _{CE} =200V	I _B =0			0.1	mA
I _{EBO}	V _{EB} =9.0V	I _C =0			0.1	mA
h _{FE}	V _{CE} =5.0V	I _C =200mA	10		40	
V _{CE(sat)}	I _C =1A	I _B =250mA			0.8	V
V _{BE(sat)}	I _C =1A	I _B =250mA			1.5	V
f _T	V _{CE} =10V	I _C =100mA	f=1.0MHz	5.0		MHz
t _f	V _{CE} =5V	I _C =100mA (UI9600)			0.6	μs
t _s					4.0	μs

MJE13003LF5 (3DD13003LF5)

