

用途:主要用于节能灯、日光灯电子镇流器及其它开关、振荡电路。

Purpose: High frequency electronic lighting ballast applications, converters, inverters, switching regulators, etc.

极限参数/Absolute maximum ratings(Ta=25°C)

参数符号 Symbol	数值 Rating	单位 Unit
$V_{CB0}$	600	V
$V_{CE0}$	400	V
$V_{EB0}$	9.0	V
$I_C$	0.75	A
$P_C(T_a=25^\circ\text{C})$	1.25	W
$P_C(T_c=25^\circ\text{C})$	30	W
$T_j$	150	°C
$T_{stg}$	-55~150	°C

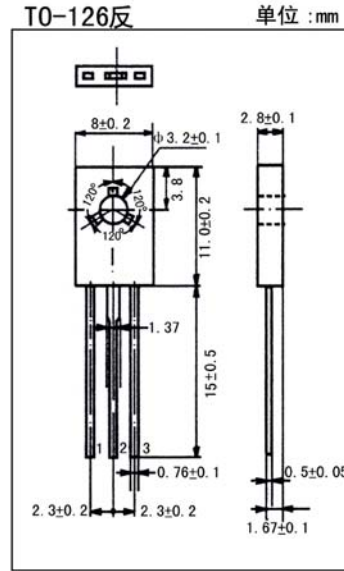

引脚: 1. B 2. C 3. E

电性能参数/Electrical characteristics(Ta=25°C)

参数符号 Symbol	测试条件 Test condition	数值 Rating			单位 Unit
		最小值 Min	典型值 Typ	最大值 Max	
$V_{CB0}$	$I_C=1\text{mA}$ $I_E=0$	600			V
$V_{CE0}$	$I_C=10\text{mA}$ $I_B=0$	400			V
$V_{EB0}$	$I_E=1\text{mA}$ $I_C=0$	9.0			V
$I_{CB0}$	$V_{CB}=600\text{V}$ $I_E=0$			0.1	mA
$I_{CE0}$	$V_{CE}=400\text{V}$ $I_B=0$			0.1	mA
$I_{EB0}$	$V_{EB}=9.0\text{V}$ $I_C=0$			0.1	mA
$h_{FE}$	$V_{CE}=5.0\text{V}$ $I_C=200\text{mA}$	10		40	
$V_{CE(sat)}$	$I_C=300\text{mA}$ $I_B=60\text{mA}$			0.5	V
$V_{BE(sat)}$	$I_C=300\text{mA}$ $I_B=60\text{mA}$			1.2	V
$f_T$	$V_{CE}=10\text{V}$ $I_C=100\text{mA}$ $f=1.0\text{MHz}$	5.0			MHz
$t_f$	$V_{CE}=5\text{V}$ $I_C=100\text{mA}$			0.6	μs
$t_s$	(UI9600)			3.5	μs

MJE13003G5 (3DD13003G5)

SOA (DC)

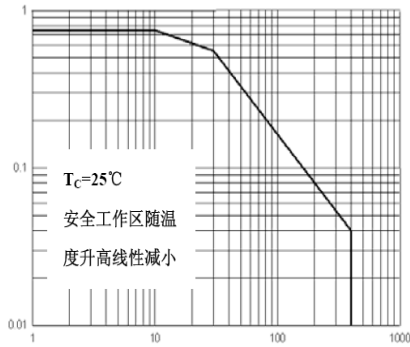

$P_c - T_c$

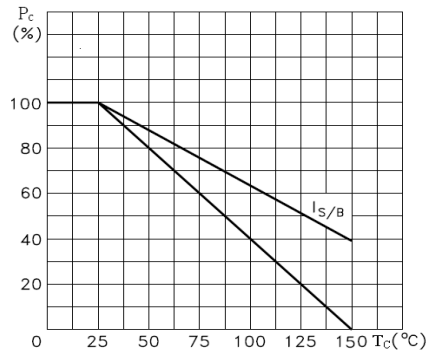

$h_{FE} - I_c$

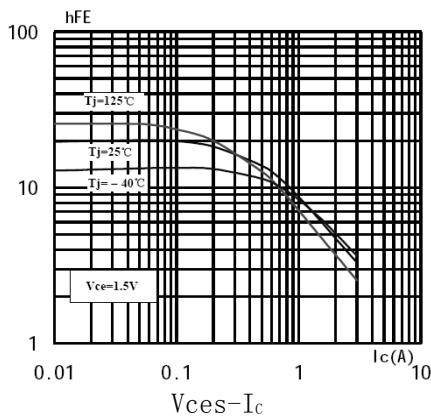

$h_{FE} - I_c$

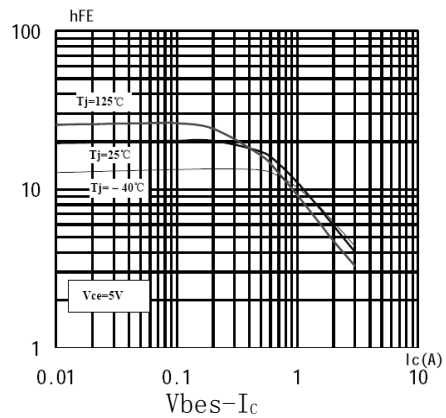

$V_{ces} - I_c$

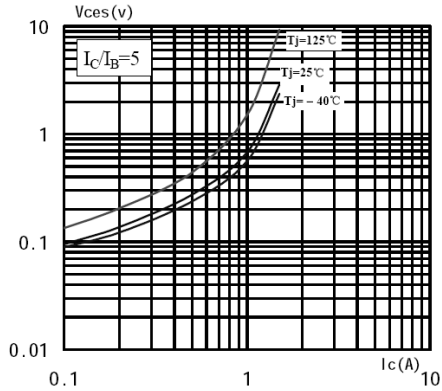

$V_{bes} - I_c$

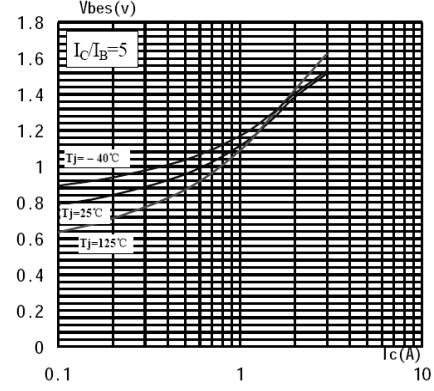

$t_s - T_a$

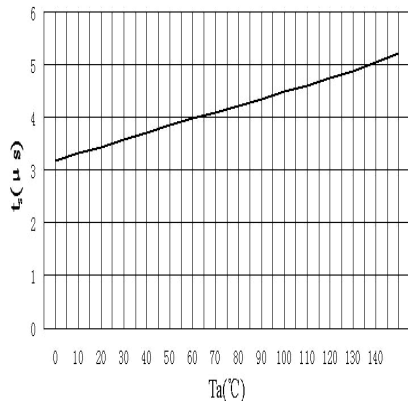

$h_{FE} - T_a$

