

用途：主要用于节能灯、日光灯电子镇流器及其它开关、振荡电路。

Purpose: High frequency electronic lighting ballast applications, converters, inverters, switching regulators, etc.

极限参数/Absolute maximum ratings ( $T_a=25^\circ\text{C}$ )

参数符号 Symbol	数值 Rating	单位 Unit
$V_{CB0}$	600	V
$V_{CE0}$	400	V
$V_{EB0}$	9.0	V
$I_C$	1.3	A
$P_C(T_a=25^\circ\text{C})$	1.0	W
$T_j$	150	$^\circ\text{C}$
$T_{\text{sag}}$	-55~150	$^\circ\text{C}$

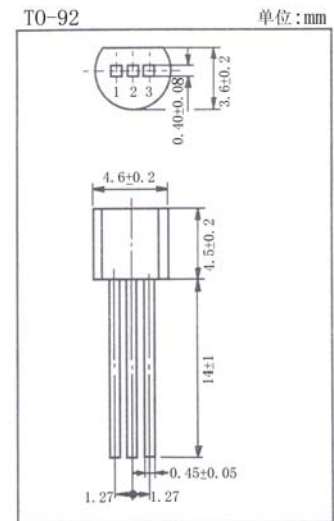
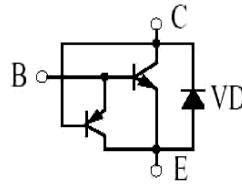

引脚: 1. E 2. C 3. B

电性能参数/Electrical characteristics ( $T_a=25^\circ\text{C}$ )

参数符号 Symbol	测试条件 Test condition		数值 Rating			单位 Unit
			最小值 Min	典型值 Typ	最大值 Max	
$V_{CB0}$	$I_C=1\text{mA}$	$I_E=0$	600			V
$V_{CE0}$	$I_C=10\text{mA}$	$I_B=0$	400			V
$V_{EB0}$	$I_E=1\text{mA}$	$I_C=0$	9.0			V
$I_{CB0}$	$V_{CB}=600\text{V}$	$I_E=0$			0.1	mA
$I_{CE0}$	$V_{CE}=400\text{V}$	$I_B=0$			0.1	mA
$I_{EB0}$	$V_{EB}=9.0\text{V}$	$I_C=0$			0.1	mA
$h_{FE(1)}$	$V_{CE}=5\text{V}$	$I_C=200\text{mA}$	10		40	
$h_{FE(2)}$	$V_{CE}=5\text{V}$	$I_C=1\text{mA}$	7			
$h_{FE(3)}$	$V_{CE}=5\text{V}$	$I_C=1.2\text{A}$	5			
$V_{CE(sat)(1)}$	$I_C=500\text{mA}$	$I_B=100\text{mA}$			0.5	V
$V_{CE(sat)(2)}$	$I_C=1.0\text{A}$	$I_B=500\text{mA}$			0.6	V
$V_{BE(sat)}$	$I_C=500\text{mA}$	$I_B=100\text{mA}$			1.2	V
$t_f$	$V_{CE}=5\text{V}$	$I_C=0.25\text{A}$			0.8	$\mu\text{S}$
$t_s$	(UI9600)				3.5	$\mu\text{S}$
$f_T$	$V_{CE}=10\text{V}$	$I_C=0.1\text{A}$	$f=1\text{MHz}$	5		MHz

# MJE13003DG1 (3DD13003DG1)

SOA (DC)

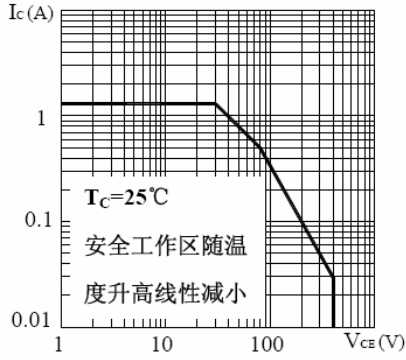

$P_c-T_c$

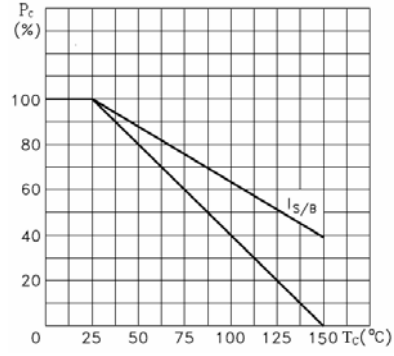

hFE-Ic

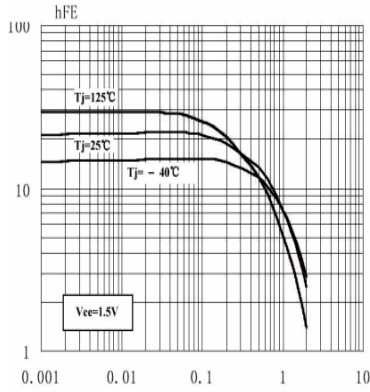

hFE-Ic

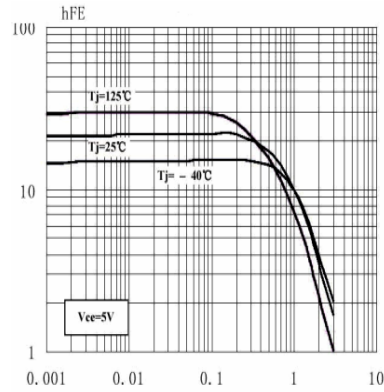

Vces-Ic

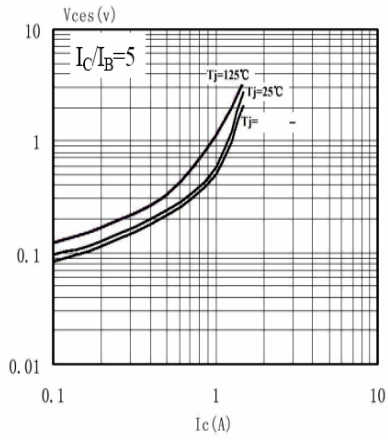

Vbes-Ic

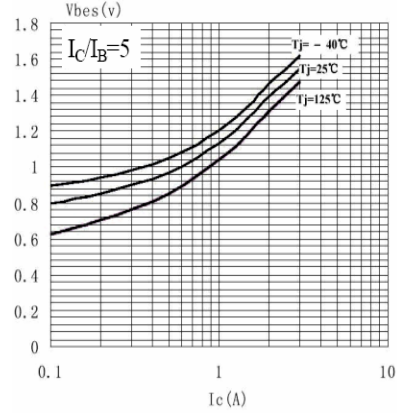

$t_s-T_a$

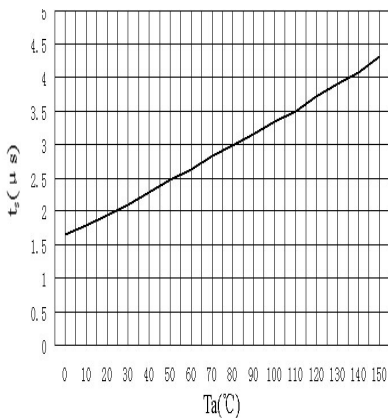

$h_{FE}-T_a$

