

MJE13002H6 (3DD13002H6)

硅 NPN 半导体三极管/SILICON NPN TRANSISTOR

用途：主要用于节能灯、日光灯电子镇流器及其它开关、振荡电路。

Purpose: High frequency electronic lighting ballast applications, converters, inverters, switching regulators, etc.

极限参数/Absolute maximum ratings(Ta=25°C)

参数符号 Symbol	数值 Rating	单位 Unit
V _{CBO}	600	V
V _{CEO}	400	V
V _{EBO}	9.0	V
I _C	1.2	A
P _C (Ta=25°C)	1.25	W
P _C (T _C =25°C)	40	W
T _J	150	°C
T _{stg}	-55~150	°C

T0-126F反 单位: mm

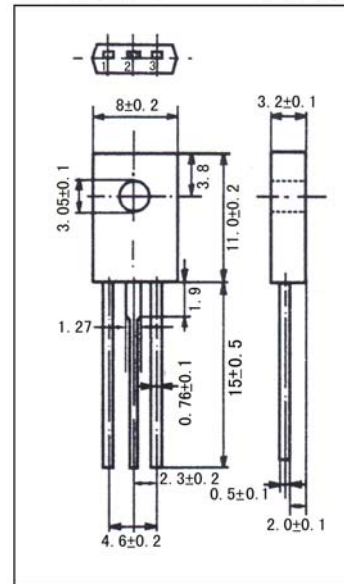

引脚： 1.B 2.C 3.E

电性能参数/Electrical characteristics(Ta=25°C)

参数符号 Symbol	测试条件 Test condition	数值 Rating			单位 Unit
		最小值 Min	典型值 Typ	最大值 Max	
V _{CBO}	I _C =1mA I _E =0	600			V
V _{CEO}	I _C =10mA I _B =0	400			V
V _{EBO}	I _E =1mA I _C =0	9.0			V
I _{CBO}	V _{CB} =600V I _E =0			0.1	mA
I _{CEO}	V _{CE} =400V I _B =0			0.1	mA
I _{EBO}	V _{EB} =9.0V I _C =0			0.1	mA
h _{FE}	V _{CE} =5.0V I _C =200mA	10		40	
V _{CE(sat)}	I _C =500mA I _B =100mA			0.8	V
V _{BE(sat)}	I _C =500mA I _B =100mA			1.2	V
f _T	V _{CE} =10V I _C =100mA f=1.0MHz	5.0			MHz
t _f	V _{CE} =5V I _C =250mA			0.6	μs
t _S	(UI9600)			3.5	μs

MJE13002H6 (3DD13002H6)

SOA (DC)

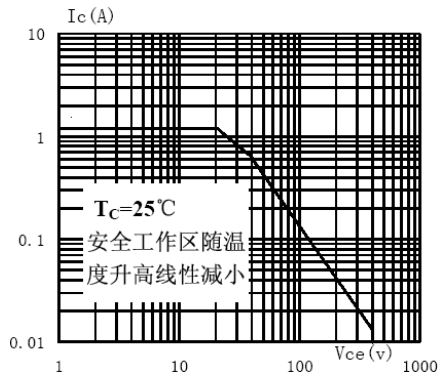

$P_c - T_c$

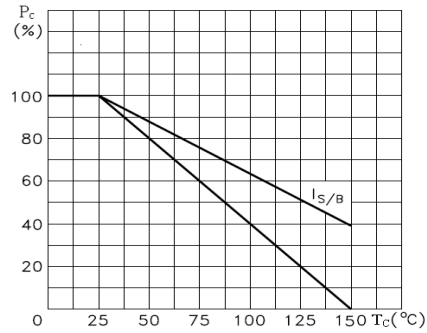

$h_{FE} - I_c$

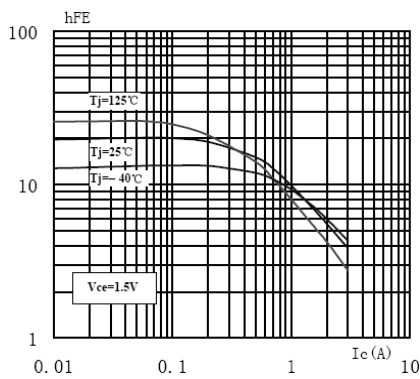

$h_{FE} - I_c$

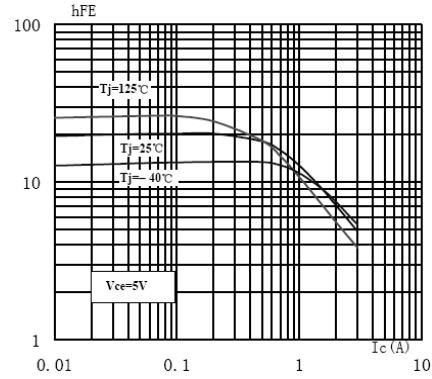

$V_{ces} - I_c$

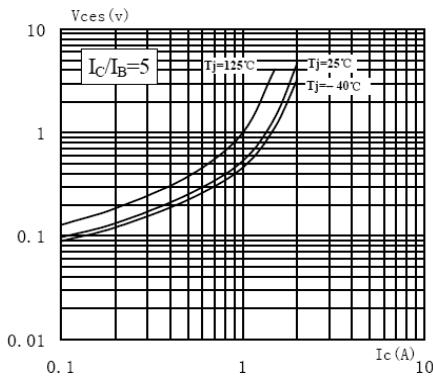

$V_{bes} - I_c$

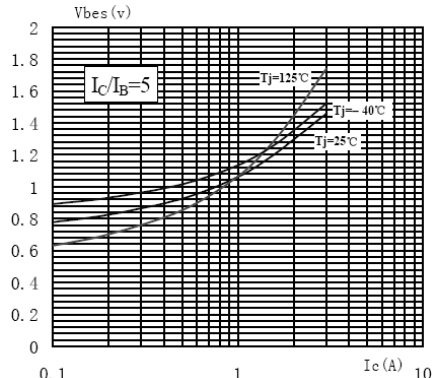

$t_s - T_a$

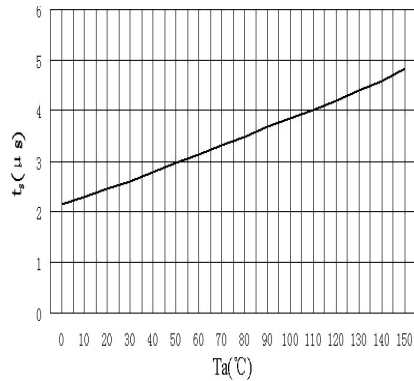

$h_{FE} - T_a$

