

用途：主要用于节能灯、日光灯电子镇流器及其它开关、振荡电路。

Purpose: High frequency electronic lighting ballast applications, converters, inverters, switching regulators, etc.

极限参数/Absolute maximum ratings(Ta=25℃)

参数符号 Symbol	数值 Rating	单位 Unit
$V_{CBO}$	600	V
$V_{CEO}$	400	V
$V_{EBO}$	9.0	V
$I_C$	0.45	A
$P_C(T_a=25^\circ\text{C})$	1.0	W
$T_j$	150	°C
$T_{stg}$	-55~150	°C

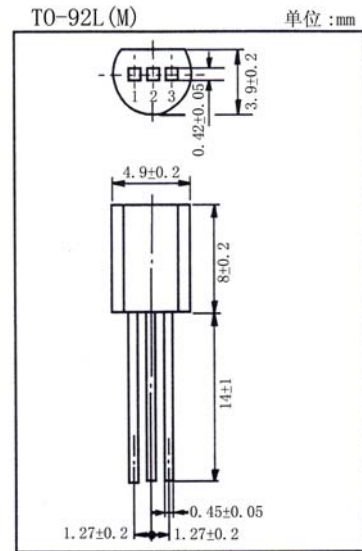

引脚： 1. E 2. C 3. B

电性能参数/Electrical characteristics(Ta=25℃)

参数符号 Symbol	测试条件 Test condition		数值 Rating			单位 Unit
			最小值 Min	典型值 Typ	最大值 Max	
$V_{CBO}$	$I_C=1\text{mA}$	$I_E=0$	600			V
$V_{CEO}$	$I_C=10\text{mA}$	$I_B=0$	400			V
$V_{EBO}$	$I_E=1\text{mA}$	$I_C=0$	9.0			V
$I_{CBO}$	$V_{CB}=600\text{V}$	$I_E=0$			0.1	mA
$I_{CEO}$	$V_{CE}=400\text{V}$	$I_B=0$			0.1	mA
$I_{EBO}$	$V_{EB}=9.0\text{V}$	$I_C=0$			0.1	mA
$h_{FE}$	$V_{CE}=5.0\text{V}$	$I_C=100\text{mA}$	10		40	
$V_{CE(sat)}$	$I_C=100\text{mA}$	$I_B=20\text{mA}$			0.5	V
$V_{BE(sat)}$	$I_C=100\text{mA}$	$I_B=20\text{mA}$			1.2	V
$f_T$	$V_{CE}=10\text{V}$	$I_C=50\text{A}$	$f=1.0\text{MHz}$	5.0		MHz
$t_f$	$V_{CE}=5\text{V}$	$I_C=100\text{mA}$			0.6	$\mu\text{s}$
$t_s$	(UI9600)				3.0	$\mu\text{s}$

# MJE13002E2 (3DD13002E2)

