

用途:用于节能灯电路。

Purpose: High frequency electronic lighting ballast applications.

极限参数/Absolute maximum ratings(Ta=25°C)

参数符号 Symbol	数值 Rating	单位 Unit
$V_{CB0}$	600	V
$V_{CE0}$	400	V
$V_{EB0}$	9.0	V
$I_C$	0.45	A
$P_C$ (Ta=25°C)	1.0	W
$T_j$	150	°C
$T_{stg}$	-55~150	°C

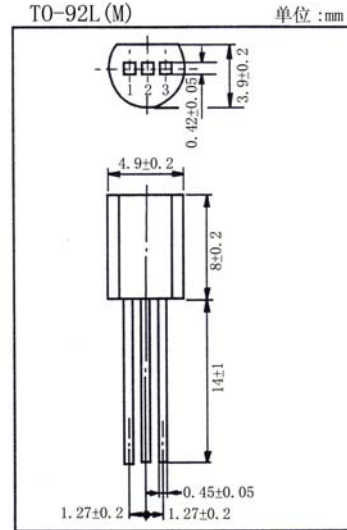

引脚: 1.E 2.C 3.B

电性能参数/Electrical characteristics(Ta=25°C)

参数符号 Symbol	测试条件 Test condition		数值 Rating			单位 Unit
			最小值 Min	典型值 Typ	最大值 Max	
$V_{CB0}$	$I_C=1mA$	$I_E=0$	600			V
$V_{CE0}$	$I_C=10mA$	$I_B=0$	400			V
$V_{EB0}$	$I_E=1mA$	$I_C=0$	9.0			V
$I_{CB0}$	$V_{CB}=600V$	$I_E=0$			0.1	mA
$I_{CE0}$	$V_{CE}=400V$	$I_B=0$			0.1	mA
$I_{EB0}$	$V_{EB}=9.0V$	$I_C=0$			0.1	mA
$h_{FE}$	$V_{CE}=5.0V$	$I_C=100mA$	10		40	
$V_{CE(sat)}$	$I_C=100mA$	$I_B=20mA$			0.5	V
$V_{BE(sat)}$	$I_C=100mA$	$I_B=20mA$			1.2	V
$f_T$	$V_{CE}=10V$	$I_C=50mA$	$f=1.0MHz$	5.0		MHz
$t_f$	$V_{CE}=5V$	$I_C=100mA$			0.6	$\mu s$
$t_s$	(UI9600)				3.0	$\mu s$

# MJE13001E2 (3DD13001E2)

