

用途:节能灯电路。

Purpose: High frequency electronic lighting ballast applications.

极限参数/Absolute maximum ratings(Ta=25°C)

参数符号 Symbol	数值 Rating	单位 Unit
V_{CB0}	600	V
V_{CE0}	400	V
V_{EB0}	9.0	V
I_C	0.25	A
P_C (Ta=25°C)	1.0	W
T_j	150	°C
T_{stg}	-55~150	°C

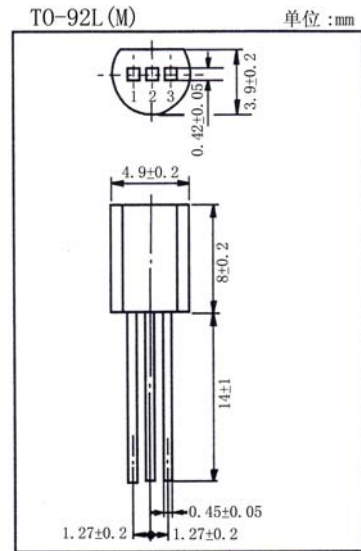

引脚: 1.E 2.C 3.B

电性能参数/Electrical characteristics(Ta=25°C)

参数符号 Symbol	测试条件 Test condition		数值 Rating			单位 Unit
			最小值 Min	典型值 Typ	最大值 Max	
V_{CB0}	$I_C=1mA$	$I_E=0$	600			V
V_{CE0}	$I_C=10mA$	$I_B=0$	400			V
V_{EB0}	$I_E=1mA$	$I_C=0$	9.0			V
I_{CB0}	$V_{CB}=600V$	$I_E=0$			0.1	mA
I_{CE0}	$V_{CE}=400V$	$I_B=0$			0.1	mA
I_{EB0}	$V_{EB}=9.0V$	$I_C=0$			0.1	mA
h_{FE}	$V_{CE}=20V$	$I_C=20mA$	10		40	
$V_{CE(sat)(1)}$	$I_C=100mA$	$I_B=20mA$			0.6	V
$V_{CE(sat)(2)}$	$I_C=50mA$	$I_B=10mA$			0.5	V
$V_{BE(sat)}$	$I_C=100mA$	$I_B=20mA$			1.2	V
f_T	$V_{CE}=20V$	$I_C=20mA$	$f=1.0MHz$	5.0		MHz
t_s	$V_{CE}=5V$	$I_C=100mA$			3.0	μs
t_f	(UI9600)				0.6	μs

