

用途：用于高功率 DC/DC 转换和功率开关。

Purpose: These devices are well suited for high efficiency switching DC/DC converters and switch mode power supplies.

特点：低栅电荷, 低反馈电容, 开关速度快。

Features: Low gate charge, low crss, fast switching.

极限参数/Absolute maximum ratings(Ta=25°C)

参数符号 Symbol	数值 Rating	单位 Unit
V_{DSS}	800	V
$I_D(T_c=25^\circ\text{C})$	1.0	A
$I_D(T_c=100^\circ\text{C})$	0.6	A
I_{DM}	3.0	A
V_{GSS}	± 30	V
E_{AS}	50	mJ
E_{AR}	2.8	mJ
I_{AR}	1.0	A
P_D	1.0	W
T_J, T_{STG}	-55 to 150	$^\circ\text{C}$

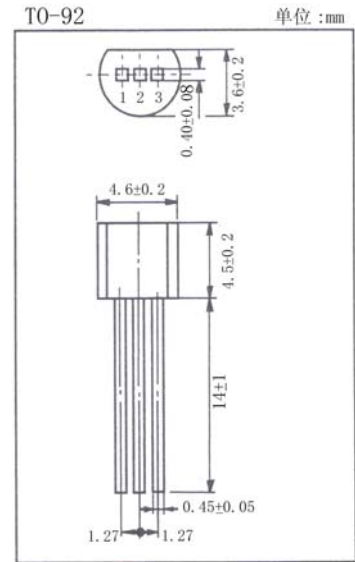

引脚: 1.G 2.D 3.S

电性能参数/Electrical Characteristics(Ta=25°C)

参数符号 Symbol	测试条件 Test Conditions		最小值 Min	典型值 Typ	最大值 Max	单位 Unit
BV_{DSS}	$V_{GS}=0V$	$I_D=250\ \mu\text{A}$	800			V
I_{DSS}	$V_{DS}=800V$	$V_{GS}=0V$			25	μA
	$V_{DS}=640V$	$T_c=125^\circ\text{C}$			100	μA
I_{GSS}	$V_{GS}=\pm 30V$	$V_{DS}=0V$			± 0.1	μA
$V_{GS(th)}$	$V_{DS}=V_{GS}$	$I_D=250\ \mu\text{A}$	2.0		4.0	V
$R_{DS(on)}$	$V_{GS}=10V$	$I_D=0.5A$			16	Ω
g_{FS}	$V_{DS}=40V$	$I_D=0.5A$		0.97		S
V_{SD}	$V_{GS}=0V$	$I_S=1.0A$			1.25	V
C_{iss}	$V_{DS}=25V$ $V_{GS}=0V$ $f=1.0\text{MHz}$			155	200	pF
C_{oss}				20	26	pF
C_{rss}				3.0	4.0	pF
$t_{d(on)}$	$V_{DD}=300V$ $I_D=1.2A$ $R_G=50\ \Omega$			10	30	ns
t_r				20	50	ns
$t_{d(off)}$				16	45	ns
t_f				25	60	ns

BRS1N80 (CS1N80S)

