

用途：用于大功率 DC/DC 转换和功率开关。

Purpose: These devices are well suited for high efficiency switching DC/DC converters and switch mode power supplies.

特点：低栅电荷, 低反馈电容, 开关速度快。

Features: Low gate charge, low crss, fast switching.

极限参数/Absolute maximum ratings(Ta=25°C)

参数符号 Symbol	数值 Rating	单位 Unit
V _{DSS}	600	V
I _D (Tc=25°C)	4.0	A
I _D (Tc=100°C)	2.5	A
I _{DM}	16	A
V _{GSS}	±30	V
E _{AS}	240	mJ
E _{AR}	10	mJ
I _{AR}	4.0	A
P _D (Tc=25°C)	100	W
T _J , T _{STG}	-55 to 150	°C

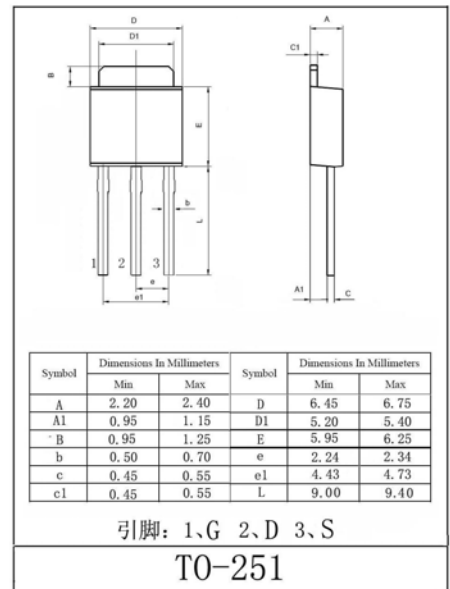

电性能参数/Electrical Characteristics(Ta=25°C)

参数符号 Symbol	测试条件 Test Conditions	最小值 Min	典型值 Typ	最大值 Max	单位 Unit
BV _{DSS}	V _{GS} =0V I _D =250 μ A	600			V
I _{DSS}	V _{DS} =600V V _{GS} =0V			10	μ A
	V _{DS} =480V T _c =125°C			100	μ A
I _{GSS}	V _{GS} =±30V V _{DS} =0V			±0.1	μ A
V _{GS(th)}	V _{DS} =V _{GS} I _D =250 μ A	2.0		4.0	V
R _{DS(on)}	V _{GS} =10V I _D =2.0A		2.0	2.5	Ω
g _{FS}	V _{DS} =40V I _D =2.0A		4.7		S
V _{SD}	V _{GS} =0V I _S =4.0A			1.4	V
C _{iss}	V _{DS} =25V V _{GS} =0V f=1.0MHz		545	710	pF
C _{oss}			60	80	pF
C _{rss}			8	11	pF
t _{d(on)}	V _{DD} =300V I _D =4.0A R _G =25 Ω		10	30	ns
t _r			35	80	ns
t _{d(off)}			45	100	ns
t _f			40	90	ns

