

用途：用于高功率 DC/DC 转换和功率开关。

Purpose: These devices are well suited for high efficiency switching DC/DC converters and switch mode power supplies.

特点：低栅电荷, 低反馈电容, 开关速度快。

Features: Low gate charge, low crss, fast switching.

极限参数/Absolute maximum ratings (Ta=25°C)

参数符号 Symbol	数值 Rating	单位 Unit
V_{DSS}	650	V
I_D (Tc=25°C)	2.0	A
I_D (Tc=100°C)	1.35	A
I_{DM}	8.0	A
V_{GSS}	±30	V
E_{AS}	120	mJ
E_{AR}	5.4	mJ
I_{AR}	2.0	A
P_D (Tc=25°C)	23	W
T_J, T_{STG}	-55 to 150	°C

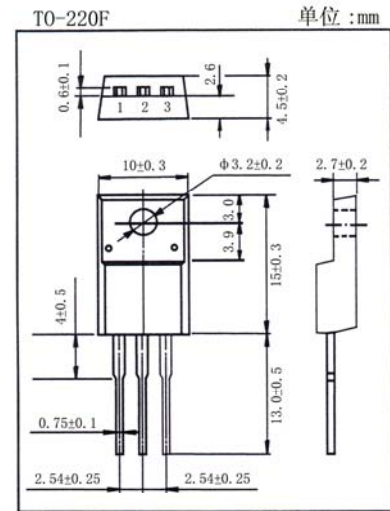

引脚： 1.G 2.D 3.S

电性能参数/Electrical Characteristics (Ta=25°C)

参数符号 Symbol	测试条件 Test Conditions	最小值 Min	典型值 Typ	最大值 Max	单位 Unit
BV_{DSS}	$V_{GS}=0V$ $I_D=250\mu A$	650			V
I_{DSS}	$V_{DS}=600V$ $V_{GS}=0V$			1.0	μA
	$V_{DS}=480V$ $T_C=125^\circ C$			100	μA
I_{GSS}	$V_{GS}=\pm 30V$ $V_{DS}=0V$			±0.1	μA
$V_{GS(th)}$	$V_{DS}=V_{GS}$ $I_D=250\mu A$	2.0		4.0	V
$R_{DS(on)}$	$V_{GS}=10V$ $I_D=1.0A$		5.6	6.5	Ω
g_{FS}	$V_{DS}=40V$ $I_D=1.0A$		5.0		S
V_{SD}	$V_{GS}=0V$ $I_S=2.0A$			1.4	V
C_{iss}	$V_{DS}=25V$ $V_{GS}=0V$ $f=1.0MHz$		320	420	pF
C_{oss}			35	46	pF
C_{rSS}			4.5	6.0	pF
$t_{d(on)}$	$V_{DD}=300V$ $I_D=2.0A$ $R_G=25\Omega$		8.0	30	ns
t_r			23	60	ns
$t_{d(off)}$			25	60	ns
t_f			28	70	ns

