

用途：用于高功率 DC/DC 转换和功率开关。

Purpose: These devices are well suited for high efficiency switching DC/DC converters and switch mode power supplies.

特点：低栅电荷, 低反馈电容, 开关速度快。

Features: Low gate charge, low crss, fast switching.

极限参数/Absolute maximum ratings($T_a=25^\circ\text{C}$)

参数符号 Symbol	数值 Rating	单位 Unit
V_{DSS}	600	V
$I_D(T_c=25^\circ\text{C})$	1.0	A
$I_D(T_c=100^\circ\text{C})$	0.6	A
I_{DM}	3.0	A
V_{GSS}	± 30	V
E_{AS}	50	mJ
E_{AR}	2.8	mJ
I_{AR}	1.0	A
$P_D(T_c=25^\circ\text{C})$	34	W
T_J, T_{STG}	-55 to 150	$^\circ\text{C}$

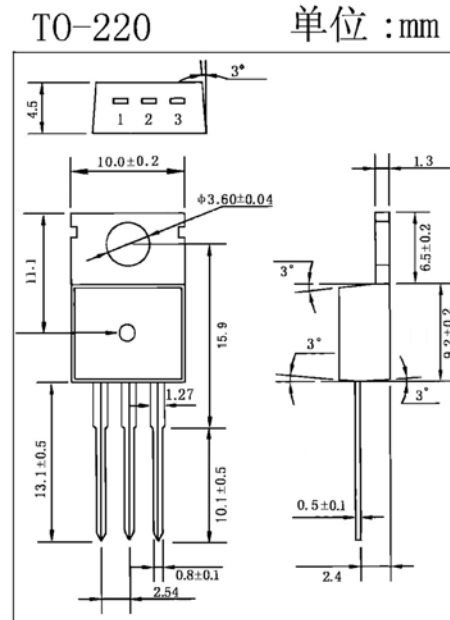

引脚：1 G 2 D 3 S

电性能参数/Electrical Characteristics($T_a=25^\circ\text{C}$)

参数符号 Symbol	测试条件 Test Conditions	最小值 Min	典型值 Typ	最大值 Max	单位 Unit
BV_{DSS}	$V_{GS}=0V$ $I_D=250\mu A$	600			V
I_{DSS}	$V_{DS}=600V$ $V_{GS}=0V$			10	μA
	$V_{DS}=480V$ $T_c=125^\circ\text{C}$			100	μA
I_{GSS}	$V_{GS}=\pm 30V$ $V_{DS}=0V$			± 0.1	μA
$V_{GS(th)}$	$V_{DS}=V_{GS}$ $I_D=250\mu A$	2.0		4.0	V
$R_{DS(on)}$	$V_{GS}=10V$ $I_D=0.5A$		9.7	12	Ω
g_{FS}	$V_{DS}=40V$ $I_D=0.5A$		0.97		S
V_{SD}	$V_{GS}=0V$ $I_S=1.0A$			1.4	V
C_{iss}	$V_{DS}=25V$ $V_{GS}=0V$ $f=1.0\text{MHz}$		155	200	pF
C_{oss}			20	26	pF
C_{rss}			3.0	4.0	pF
$t_{d(on)}$	$V_{DD}=300V$ $I_D=1.2A$ $R_G=50\Omega$		10	30	ns
t_r			20	50	ns
$t_{d(off)}$			16	45	ns
t_f			25	60	ns

BR1N60 (CS1N60)

