

SWITCHING APPLICATION.
INTERFACE CIRCUIT AND DRIVER CIRCUIT APPLICATION.

FEATURES

- With Built-in Bias Resistors.
- Simplify Circuit Design.
- Reduce a Quantity of Parts and Manufacturing Process.
- Thin fine Pitch Small Package.

EQUIVALENT CIRCUIT

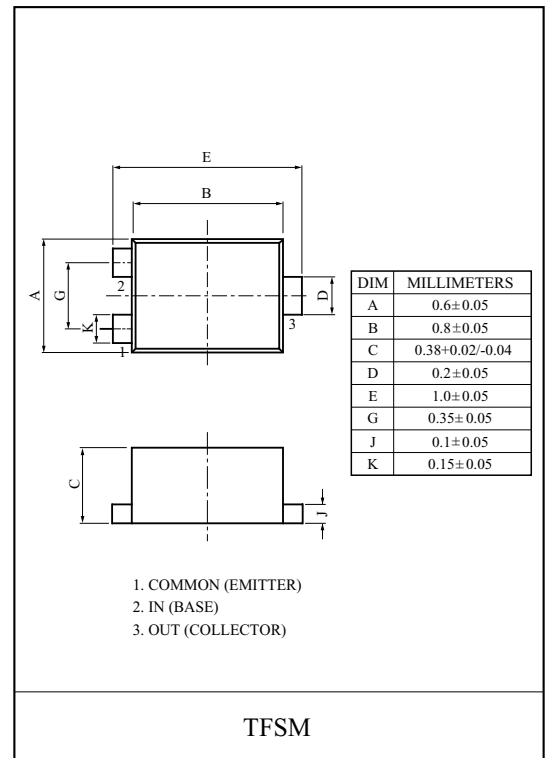
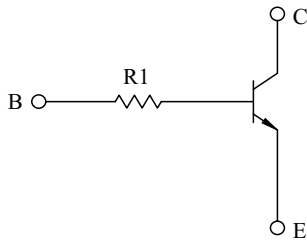

MAXIMUM RATING (Ta=25 °C)

CHARACTERISTIC	SYMBOL	RATING	UNIT
Collector-Base Voltage	V_{CBO}	20	V
Collector-Emitter Voltage	V_{CEO}	20	V
Emitter-Base Voltage	V_{EBO}	5	V
Collector Current	I_C	50	mA

CHARACTERISTIC	SYMBOL	RATING	UNIT
Collector Power Dissipation	P_C	50	mW
Junction Temperature	T_j	150	°C
Storage Temperature Range	T_{stg}	-55 ~ 150	°C

ELECTRICAL CHARACTERISTICS (Ta=25 °C)

CHARACTERISTIC	SYMBOL	TEST CONDITION	MIN.	TYP.	MAX.	UNIT
Collector Cut-off Current	I_{CBO}	$V_{CB}=20V, I_E=0$	-	-	100	nA
Emitter Cut-off Current	I_{EBO}	$V_{EB}=5V, I_C=0$	-	-	100	nA
DC Current Gain	h_{FE}	$V_{CE}=5V, I_C=1mA$	300	-	-	
Collector-Emitter Saturation Voltage	$V_{CE(sat)}$	$I_C=5mA, I_B=0.25mA$	-	-	0.15	V
Collector Output Capacitance	C_{ob}	$V_{CB}=10V, I_E=0, f=1MHz$	-	1.2	-	pF
Input Resistor	KRC160F	-	-	4.7	-	k Ω
	KRC161F		-	10	-	
	KRC163F		-	22	-	
	KRC164F		-	47	-	

MARK SPEC

TYPE	KRC160F	KRC161F	KRC163F	KRC164F
MARK	FK	FL	FN	FP

Marking

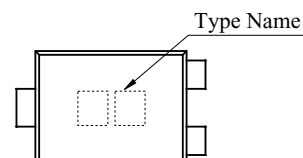

KRC160F~KRC164F

$I_O - V_{I(ON)}$

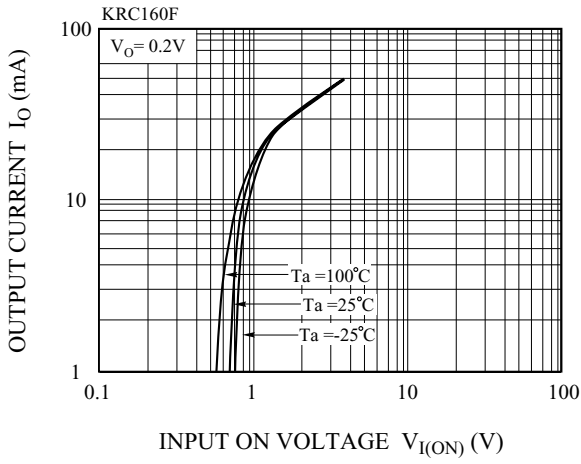

$I_O - V_{I(OFF)}$

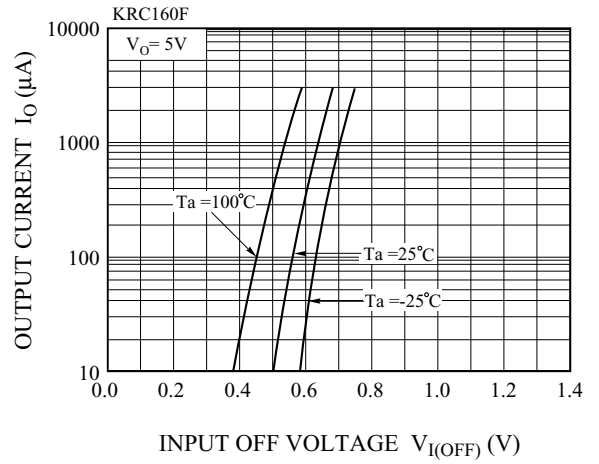

$G_I - I_O$

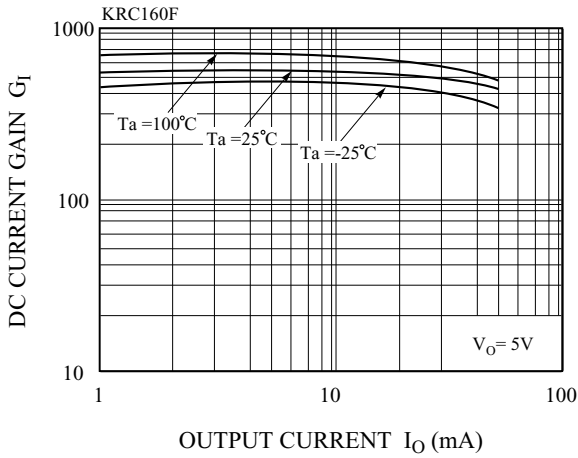

$V_{O(ON)} - I_O$

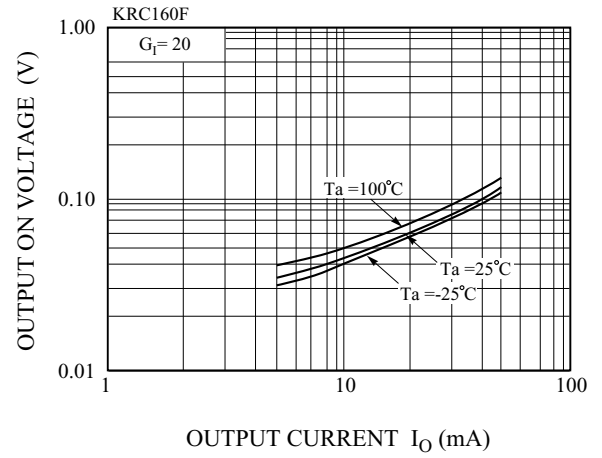

$I_O - V_{I(ON)}$

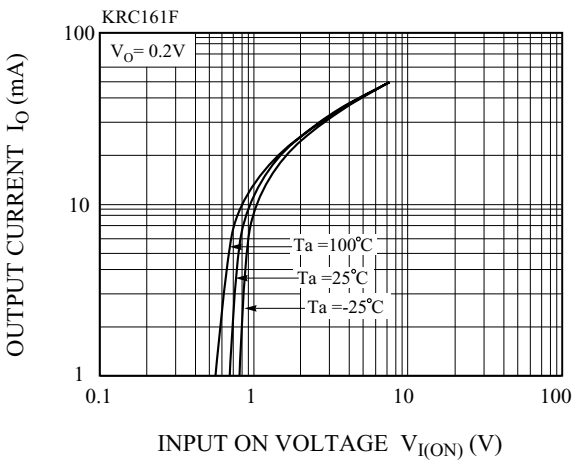

$I_O - V_{I(OFF)}$

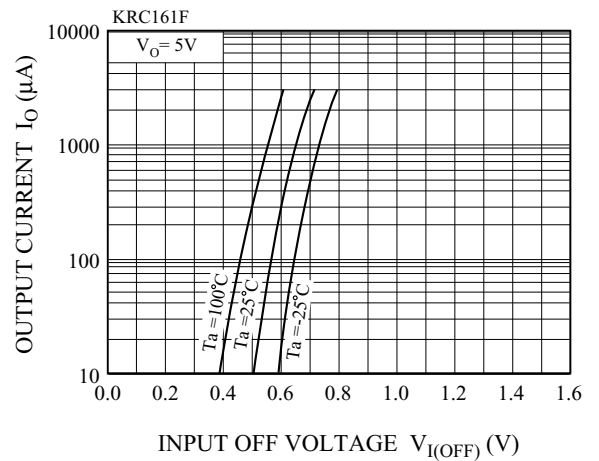

KRC160F~KRC164F

$G_I - I_O$

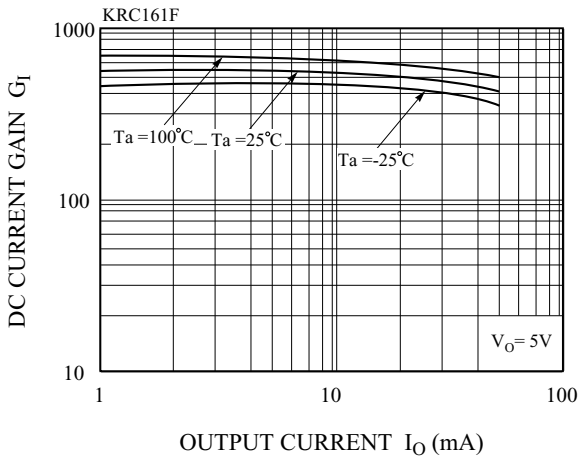

$V_{O(ON)} - I_O$

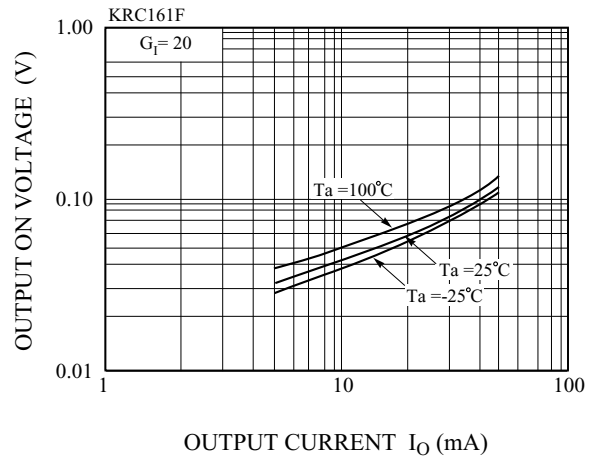

$I_O - V_{I(ON)}$

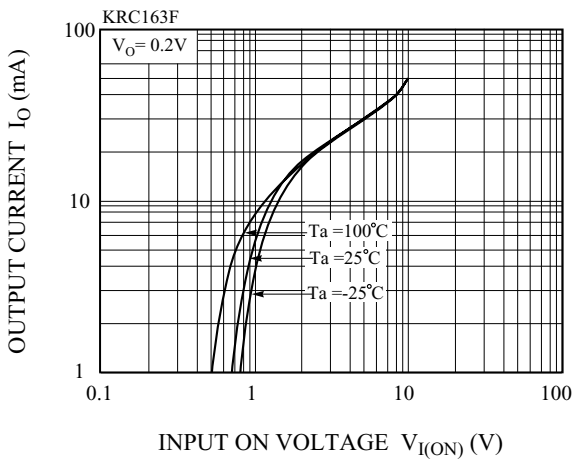

$I_O - V_{I(OFF)}$

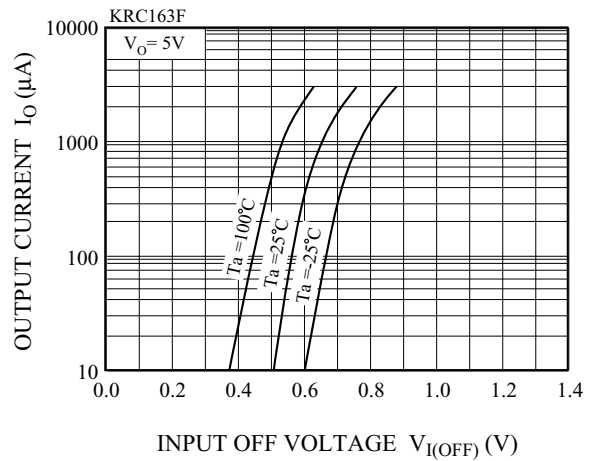

$G_I - I_O$

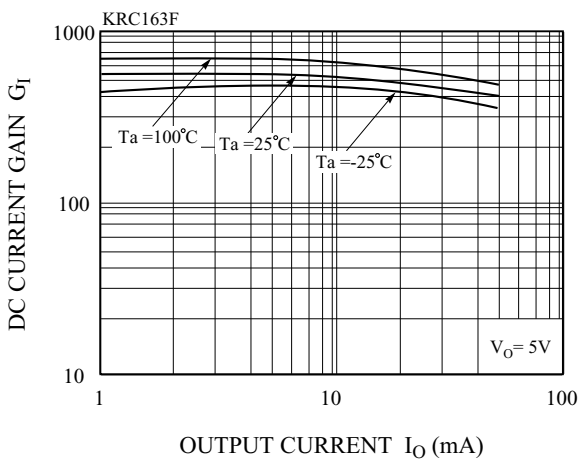

$V_{O(ON)} - I_O$

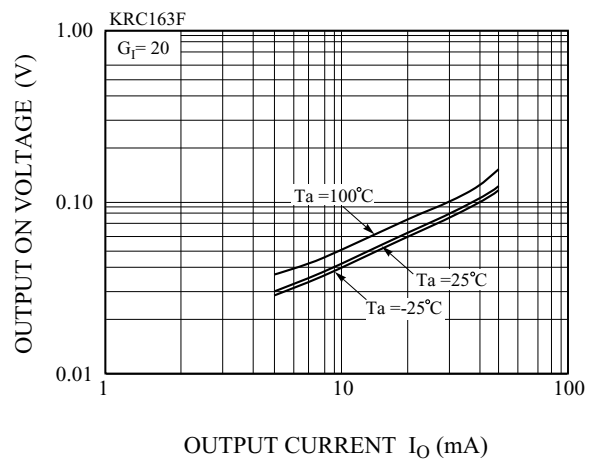

KRC160F~KRC164F

$I_O - V_{I(ON)}$

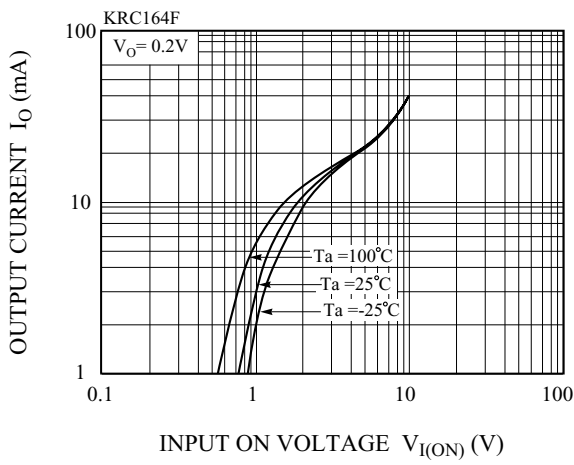

$I_O - V_{I(OFF)}$

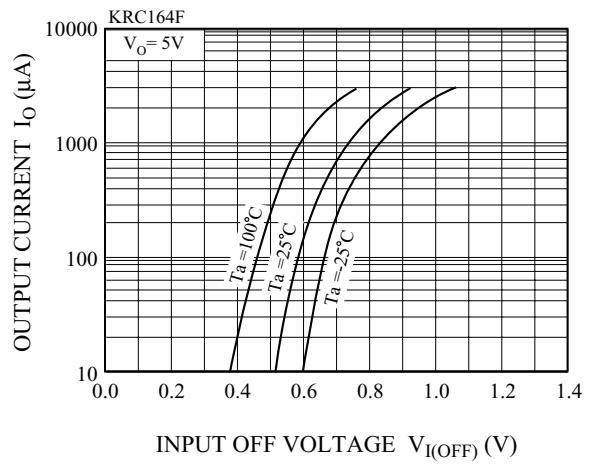

$G_I - I_O$

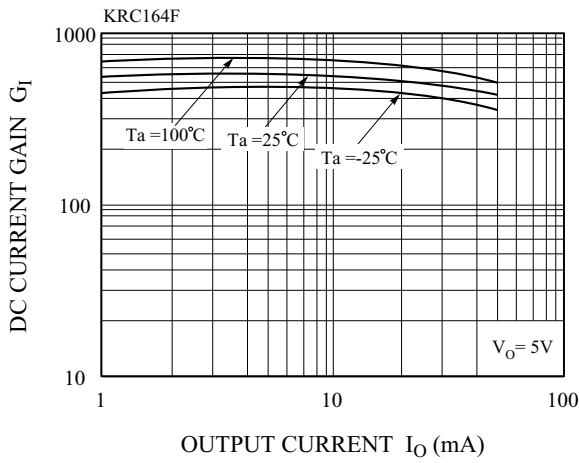

$V_{O(ON)} - I_O$

