

用途:用于中功率放大。

Purpose: Medium power amplifier.

特点: $V_{CE(sat)}$ 低,与 2SA885 (3CA885) 互补可得到 3W 输出。

Features: Low $V_{CE(sat)}$, 3W output in complementary pair with 2SA885 (3CA885).

极限参数/Absolute maximum ratings ($T_a=25^\circ\text{C}$)

参数符号 Symbol	数值 Rating	单位 Unit
V_{CBO}	45	V
V_{CEO}	35	V
V_{EBO}	5.0	V
I_C	1.0	A
I_{CP}	1.5	A
P_C	1.2*	W
P_C	5**	W
T_j	150	$^\circ\text{C}$
T_{stg}	-55~150	$^\circ\text{C}$

*Without heat sink

**With a 100×100×2mm AL heat sink

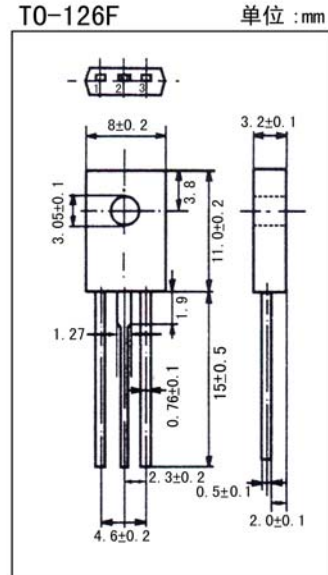

引脚: 1. E 2. C 3. B

电性能参数/Electrical characteristics ($T_a=25^\circ\text{C}$)

参数符号 Symbol	测试条件 Test condition		数值 Rating			单位 Unit
			最小值 Min	典型值 Typ	最大值 Max	
V_{CBO}	$I_C=1.0\text{mA}$	$I_E=0$	45			V
V_{CEO}	$I_C=2.0\text{mA}$	$I_B=0$	35			V
I_{CBO}	$V_{CB}=20\text{V}$	$I_E=0$			0.1	μA
I_{CEO}	$V_{CE}=20\text{V}$	$I_B=0$			100	μA
I_{EBO}	$V_{EB}=5.0\text{V}$	$I_C=0$			10	μA
$h_{FE(1)}$	$V_{CE}=10\text{V}$	$I_C=500\text{mA}$	85	160	340	
$h_{FE(2)}$	$V_{CE}=5.0\text{V}$	$I_C=1.0\text{A}$	50			
$V_{CE(sat)}$	$I_C=500\text{mA}$	$I_B=50\text{mA}$			0.5	V
f_T	$V_{CE}=10\text{V}$	$I_C=50\text{mA}$		200		MHz
C_{ob}	$V_{CB}=10\text{V}$	$I_E=0$			20	pF

$h_{FE(1)}$ 分档/ $h_{FE(1)}$ classifications: Q:85~170 R:120~240 S:170~340

