

用途:用于一般放大。

Purpose: General purpose amplifier.

特点:共基极输出电容小,与 2SA933A(3CG933A)互补。

Features: Small base output capacitance, complementary pair with 2SA933A(3CG933A).

极限参数/Absolute maximum ratings(Ta=25°C)

参数符号 Symbol	数值 Rating	单位 Unit
$V_{CB0}$	60	V
$V_{CE0}$	50	V
$V_{EB0}$	7.0	V
$I_C$	150	mA
$P_C$	300	mW
$T_j$	150	°C
$T_{stg}$	-55~150	°C

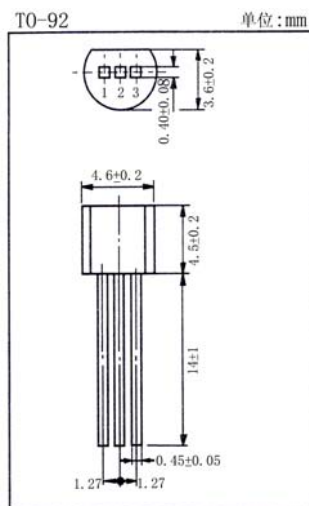

引脚: 1. E 2. C 3. B

电性能参数/Electrical characteristics(Ta=25°C)

参数符号 Symbol	测试条件 Test condition		数值 Rating			单位 Unit
			最小值 Min	典型值 Typ	最大值 Max	
$V_{CB0}$	$I_C=50 \mu A$	$I_E=0$	60			V
$V_{CE0}$	$I_C=1.0mA$	$I_B=0$	50			V
$V_{EB0}$	$I_E=50 \mu A$	$I_C=0$	7.0			V
$I_{CB0}$	$V_{CB}=60V$	$I_E=0$			0.1	$\mu A$
$I_{EB0}$	$V_{EB}=7.0V$	$I_C=0$			0.1	$\mu A$
$h_{FE}$	$V_{CE}=6.0V$	$I_C=1.0mA$	120		560	
$V_{CE(sat)}$	$I_C=50mA$	$I_B=5.0mA$			0.4	V
$f_T$	$V_{CE}=12V$	$I_E=-2.0mA$		180		MHz
$C_{ob}$	$V_{CB}=12V$	$I_E=0$		2.0	3.5	pF

$h_{FE}$  分档/ $h_{FE}$  classifications: Q:120~270 R:180~390 S:270~560

# 2SC1740 (3DG1740)

