

20V P-Channel Enhancement-Mode MOSFET

● Features

Low on-resistance

$R_{DS(ON)} (V_{GS}=4.5V, I_{ds}=2.8A) = 100m\Omega$

$R_{DS(ON)} (V_{GS}=2.5V, I_{ds}=2.0A) = 150m\Omega$

High Density Cell Design For Ultra Low On-Resistance

Fully Characterized Avalanche Voltage and Current

Improved Shoot-Through FOM

- We declare that the material of product are Halogen Free and compliance with RoHS requirements.

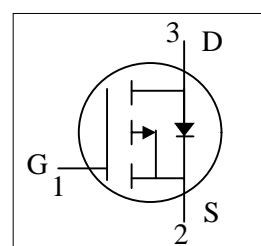
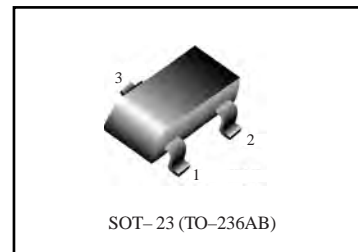

● Ordering Information

Device	Marking	Shipping
FTK2301	01	3000/Tape&Reel

● Maximum Ratings and Thermal Characteristics (T_A = 25°C unless otherwise noted)

Parameter	Symbol	Limit	Unit	
Drain-Source Voltage	V _{DS}	-20	V	
Gate-Source Voltage	V _{GS}	± 8		
Continuous Drain Current	I _D	-2.3	A	
Pulsed Drain Current ¹⁾	I _{DM}	-8		
Maximum Power Dissipation	P _D	T _A = 25°C	0.9	W
		T _A = 75°C	0.57	
Operating Junction and Storage Temperature Range	T _J , T _{stg}	-55 to 150	°C	
Junction-to-Case Thermal Resistance	R _{qJC}		°C/W	
Junction-to-Ambient Thermal Resistance (PCB mounted) ²⁾	R _{qJA}	140		

Note: 1. Repetitive Rating: Pulse width limited by the Maximum junction temperature

2. 1-in² 2oz Cu PCB board

3. Guaranteed by design; not subject to production testing

ELECTRICAL CHARACTERISTICS

Parameter	Symbol	Test Condition	Min	Typ	Max	Unit
Static						
Drain-Source Breakdown Voltage	BV_{DSS}	$V_{GS} = 0V, I_D = -250 \mu A$	-20	-	-	V
Drain-Source On-State Resistance	$R_{DS(ON)}$	$V_{GS} = -4.5V, I_D = -2.8A$		69	100	$m\Omega$
Drain-Source On-State Resistance	$R_{DS(ON)}$	$V_{GS} = -2.5V, I_D = -2.0A$		83	150	$m\Omega$
Gate Threshold Voltage	$V_{GS(th)}$	$V_{DS} = V_{GS}, I_D = -250 \mu A$	-0.45		-0.95	V
Zero Gate Voltage Drain Current	I_{DSS}	$V_{DS} = -9.6V, V_{GS} = 0V$			-1	μA
Gate Body Leakage	I_{GSS}	$V_{GS} = \pm 8V, V_{DS} = 0V$			± 100	nA
Gate Resistance	R_g					Ω
Forward Transconductance	g_{fs}	$V_{DS} = -5V, I_D = -4.0A$		6.5		S
Dynamic 3)						
Total Gate Charge	Q_g	$V_{DS} = -6V, I_D = -2.8A$ $V_{GS} = -4.5V$		15.23		nC
Gate-Source Charge	Q_{gs}			5.49		nC
Gate-Drain Charge	Q_{gd}			2.74		nC
Turn-On Delay Time	$t_{d(on)}$	$V_{DD} = -6V, R_L = 6\Omega$ $I_D = -1A, V_{GEN} = -4.5V$ $R_G = 6\Omega$		17.28		ns
Turn-On Rise Time	t_r			3.73		ns
Turn-Off Delay Time	$t_{d(off)}$			36.05		ns
Turn-Off Fall Time	t_f			6.19		ns
Input Capacitance	C_{iss}	$V_{DS} = -6V, V_{GS} = 0V$ $f = 1.0MHz$		882.51		pF
Output Capacitance	C_{oss}			145.54		pF
Reverse Transfer Capacitance	C_{rss}			97.26		pF
Source-Drain Diode						
Max. Diode Forward Current	I_S				-2.4	A
Diode Forward Voltage	V_{SD}	$I_S = -0.75A, V_{GS} = 0V$		-0.8	-1.2	V

Note: Pulse test: Pulse Width $\leq 300\mu s$, Duty Cycle $\leq 2.0\%$.

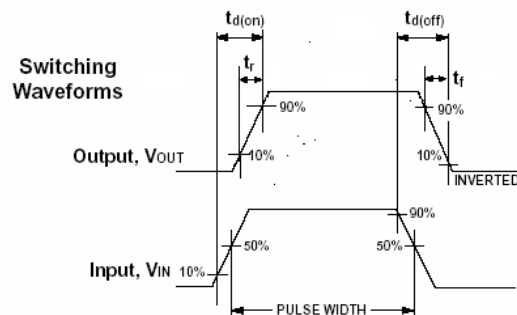
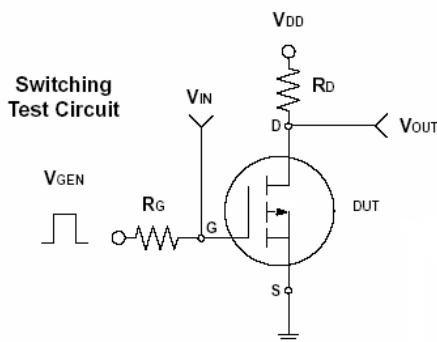

Output Characteristics

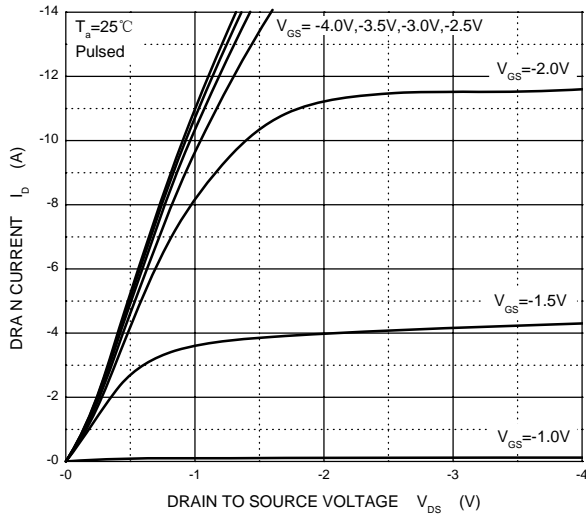

Transfer Characteristics

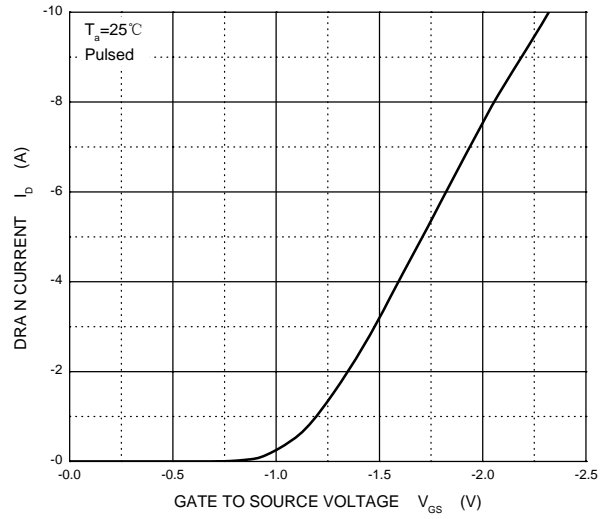

$R_{DS(ON)}$ — I_D

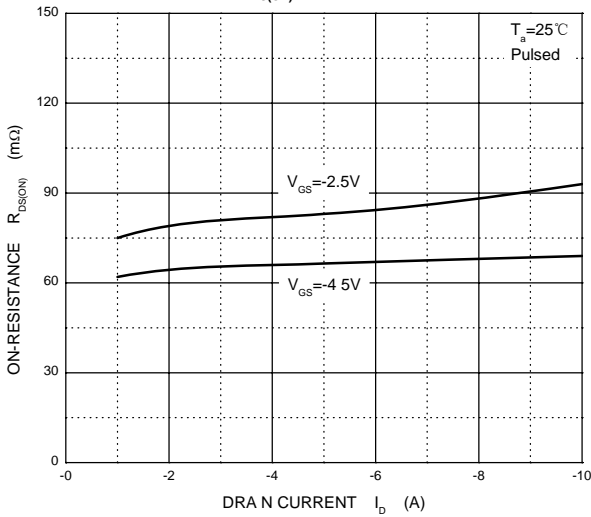

$R_{DS(ON)}$ — V_{GS}

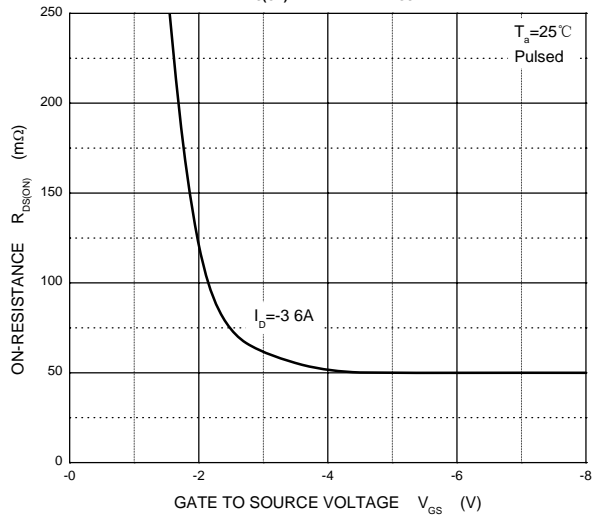

I_S — V_{SD}

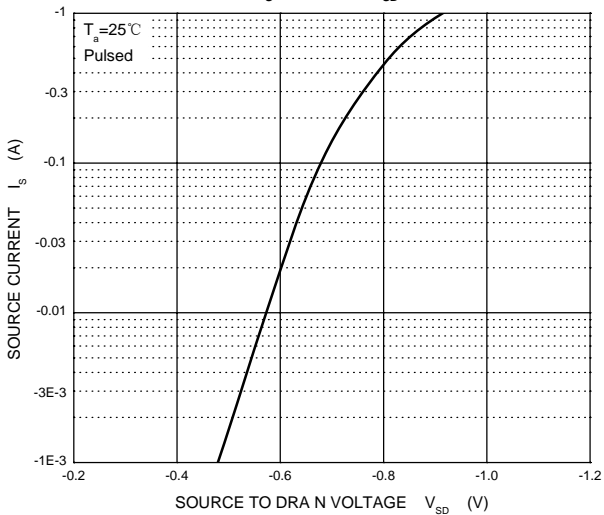

SOT -23

NOTES:

1. DIMENSIONING AND TOLERANCING PER ANSI Y14.5M,1982
2. CONTROLLING DIMENSION: INCH.

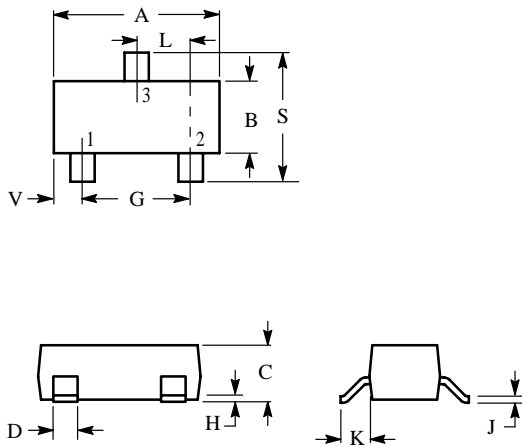

DIM	INCHES		MILLIMETERS	
	MIN	MAX	MIN	MAX
A	0.1102	0.1197	2.80	3.04
B	0.0472	0.0551	1.20	1.40
C	0.0350	0.0440	0.89	1.11
D	0.0150	0.0200	0.37	0.50
G	0.0701	0.0807	1.78	2.04
H	0.0005	0.0040	0.013	0.100
J	0.0034	0.0070	0.085	0.177
K	0.0140	0.0285	0.35	0.69
L	0.0350	0.0401	0.89	1.02
S	0.0830	0.1039	2.10	2.64
V	0.0177	0.0236	0.45	0.60

