

Feathers:

- Advanced trench process technology
- Ultra low Rdson, typical 16mohm
- High avalanche energy, 100% test
- Fully characterized avalanche voltage and current

ID =60A
BV=100V
Rdson=22mohm

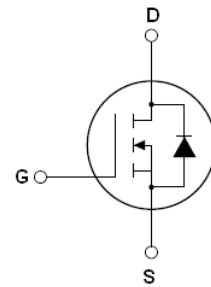

FTK3022 TOP View (TO-220)

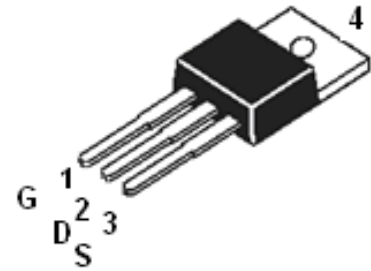
Description:

The FTK3022 is a new generation of middle voltage and high current N-Channel enhancement mode trench power MOSFET. This new technology increases the device reliability and electrical parameter repeatability. FTK3022 is assembled in high reliability and qualified assembly house.

Application:

- Power switching application

Absolute Maximum Ratings

	Parameter	Max.	Units
$I_D@T_c=25^\circ\text{C}$	Continuous drain current, VGS@10V	60	A
$I_D@T_c=100^\circ\text{C}$	Continuous drain current, VGS@10V	50	
I_{DM}	Pulsed drain current ①	240	
$P_D@T_c=25^\circ\text{C}$	Power dissipation	150	W
	Linear derating factor	2.0	W/°C
V_{GS}	Gate-to-Source voltage	±20	V
dv/dt	Peak diode recovery voltage	31	v/ns
E_{AS}	Single pulse avalanche energy ②	240	mJ
E_{AR}	Repetitive avalanche energy	TBD	
T_J T_{STG}	Operating Junction and Storage Temperature Range	-55 to +150	°C

Thermal Resistance

	Parameter	Min.	Typ.	Max.	Units
$R_{\theta JC}$	Junction-to-case	—	0.83	—	C/W
$R_{\theta JA}$	Junction-to-ambient	—	—	62	

Electrical Characteristics @TJ=25 °C(unless otherwise specified)

	Parameter	Min.	Typ.	Max.	Units	Test Conditions
BV_{DSS}	Drain-to-Source breakdown voltage	100	—	—	V	$V_{GS}=0V, I_D=250\mu A$
$R_{DS(on)}$	Static Drain-to-Source on-resistance	—	16	22	mΩ	$V_{GS}=10V, I_D=30A$
$V_{GS(th)}$	Gate threshold voltage	2.0	3	4.0	V	$V_{DS}=V_{GS}, I_D=250\mu A$
g_{fs}	Forward transconductance	-	58	—	S	$V_{DS}=5V, I_D=30A$
I_{DSS}	Drain-to-Source leakage current	—	—	1	μA	$V_{DS}=100V, V_{GS}=0V$
		—	—	10		$V_{DS}=100V, V_{GS}=0V, T_J=150^\circ\text{C}$

I_{GSS}	Gate-to-Source forward leakage	—	—	100	nA	$V_{GS}=20V$
	Gate-to-Source reverse leakage	—	—	-100		$V_{GS}=-20V$
Q_g	Total gate charge	—	90	—	nC	$I_D=30A$
Q_{gs}	Gate-to-Source charge	—	14	—		$V_{DD}=30V$
Q_{gd}	Gate-to-Drain("Miller") charge	—	24	—		$V_{GS}=10V$
$t_{d(on)}$	Turn-on delay time	—	18.2	—	nS	$V_{DD}=30V$
t_r	Rise time	—	15.6	—		$I_D=2A, R_L=15\Omega$
$t_{d(off)}$	Turn-Off delay time	—	70.5	—		$R_G=2.5\Omega$
t_f	Fall time	—	13.8	—		$V_{GS}=10V$
C_{iss}	Input capacitance	—	3150	—	pF	$V_{GS}=0V$
C_{oss}	Output capacitance	—	300	—		$V_{DS}=25V$
C_{rss}	Reverse transfer capacitance	—	240	—		$f=1.0MHz$

Source-Drain Ratings and Characteristics

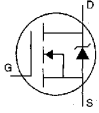
	Parameter	Min.	Typ.	Max.	Units	Test Conditions
I_S	Continuous Source Current (Body Diode)	—	—	60	A	MOSFET symbol showing the integral reverse p-n junction diode. 
I_{SM}	Pulsed Source Current (Body Diode) ①	—	—	240		
V_{SD}	Diode Forward Voltage	—	—	1.3	V	$T_J=25^\circ C, I_S=30A, V_{GS}=0V$ ③
t_{rr}	Reverse Recovery Time	—	57	—	nS	$T_J=25^\circ C, I_F=60A$
Q_{rr}	Reverse Recovery Charge	—	107	—	nC	$di/dt=100A/\mu s$ ③
t_{on}	Forward Turn-on Time	Intrinsic turn-on time is negligible (turn-on is dominated by $L_s + L_D$)				

Notes:

- ① Repetitive rating; pulse width limited by max junction temperature.
- ② Test condition: $L=0.3mH, I_D=40A, V_{DD}=50V$
- ③ Pulse width $\leq 300\mu s$, duty cycle $\leq 1.5\%$; $R_G=25\Omega$ Starting $T_J=25^\circ C$

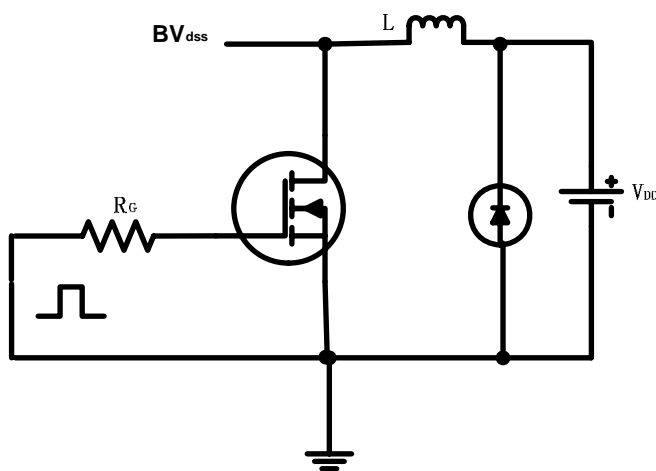

EAS test circuit

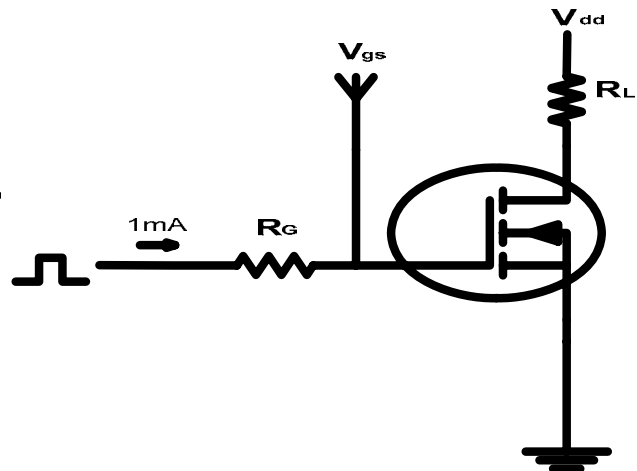

Gate charge test circuit

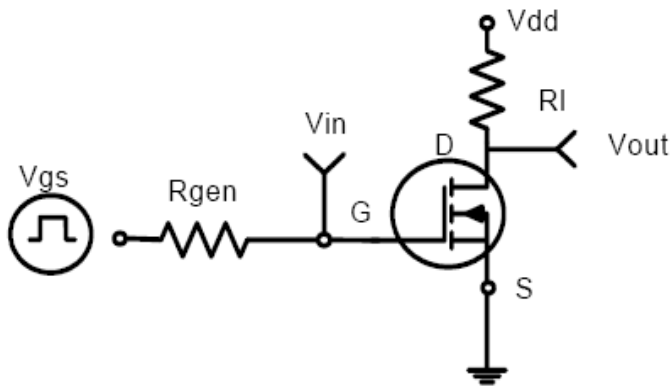

Switch Time Test Circuit:

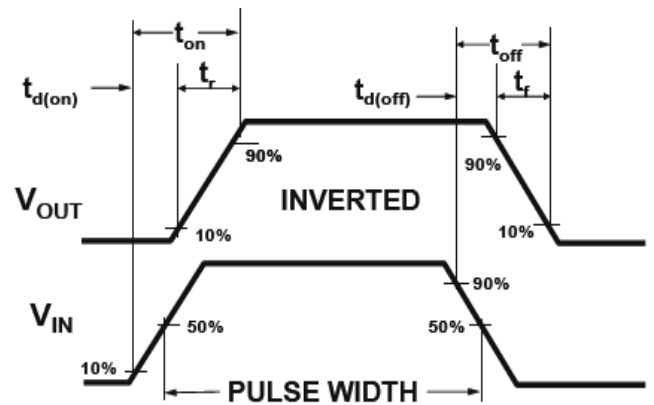

Switch Waveforms:

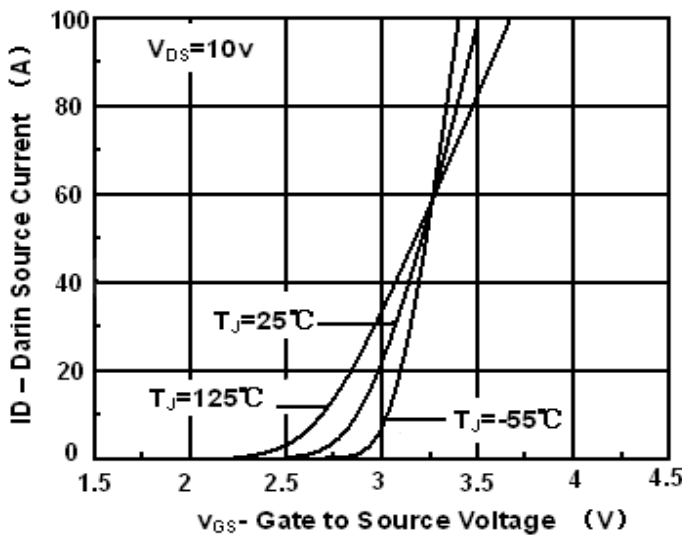

Transfer Characteristic

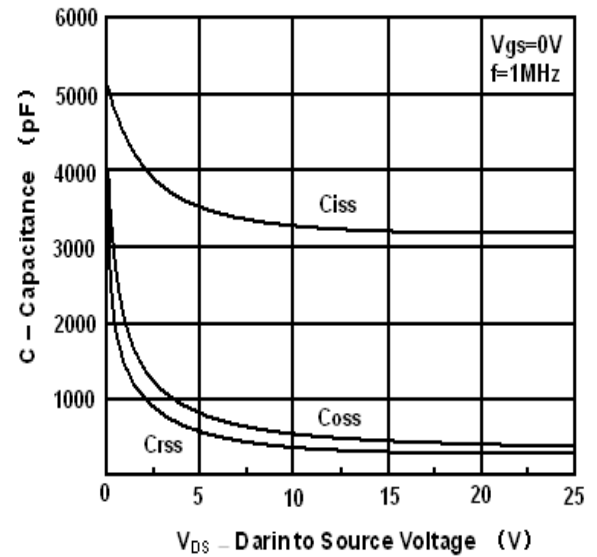

Capacitance:

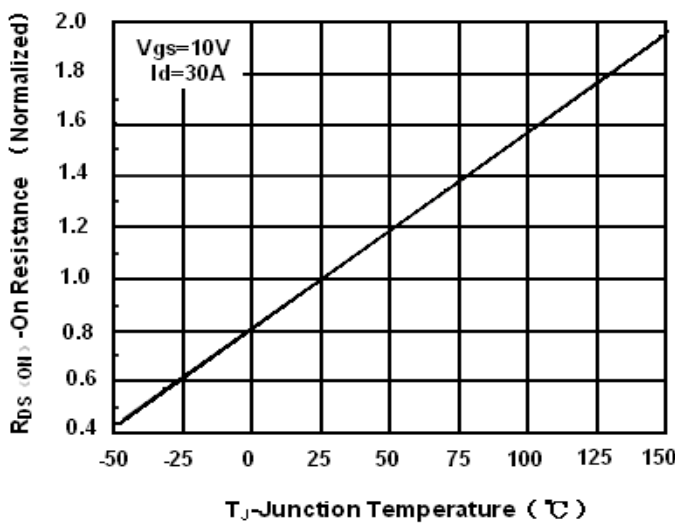

On Resistance vs Junction Temperature

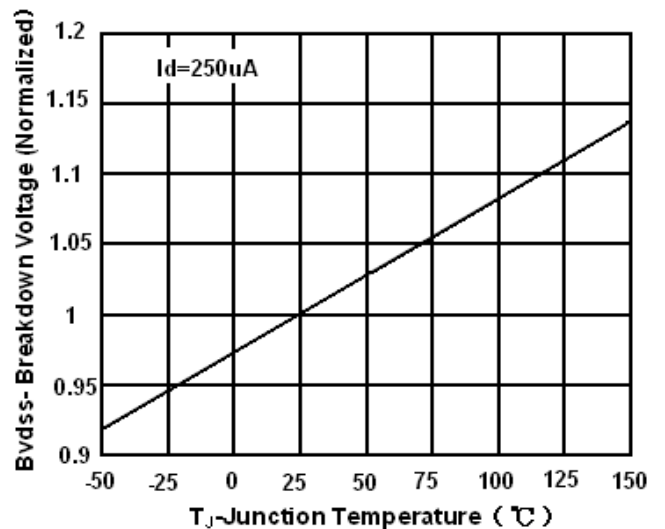

Breakdown Voltage vs Junction Temperature

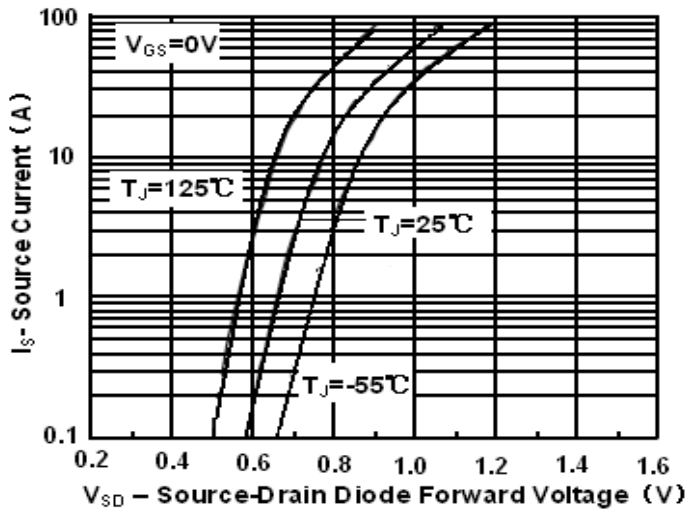

Source-Drain Diode Forward Voltage

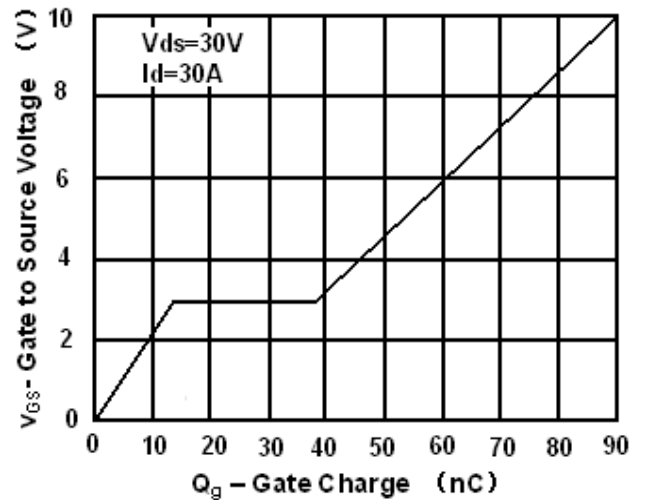

Gate Charge

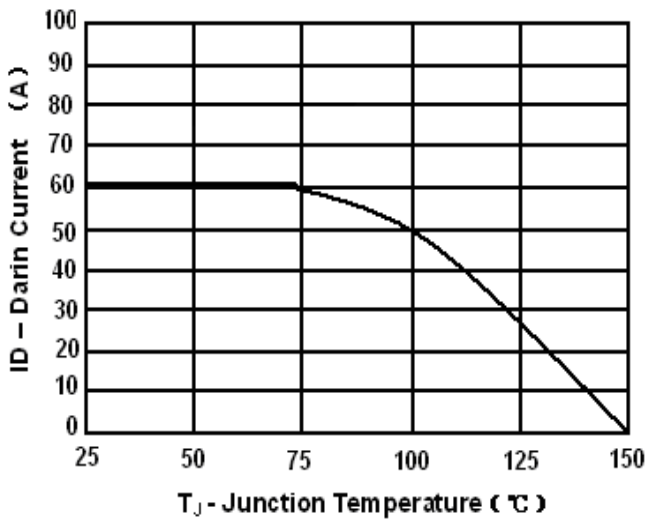

Max Drain Current vs Junction Temperature

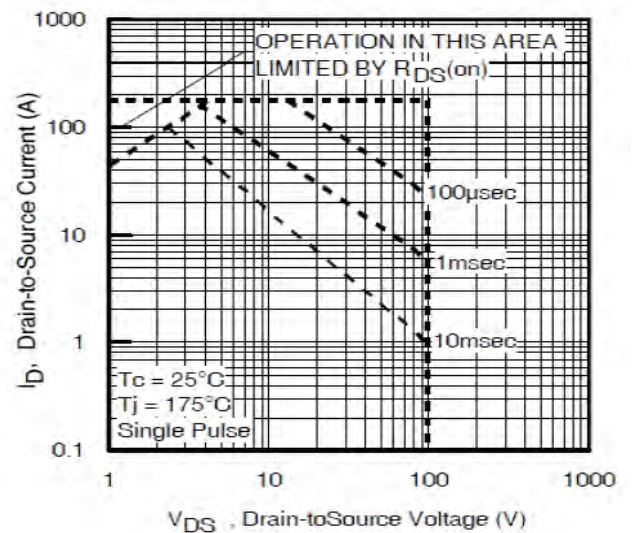

Safe Operation Area

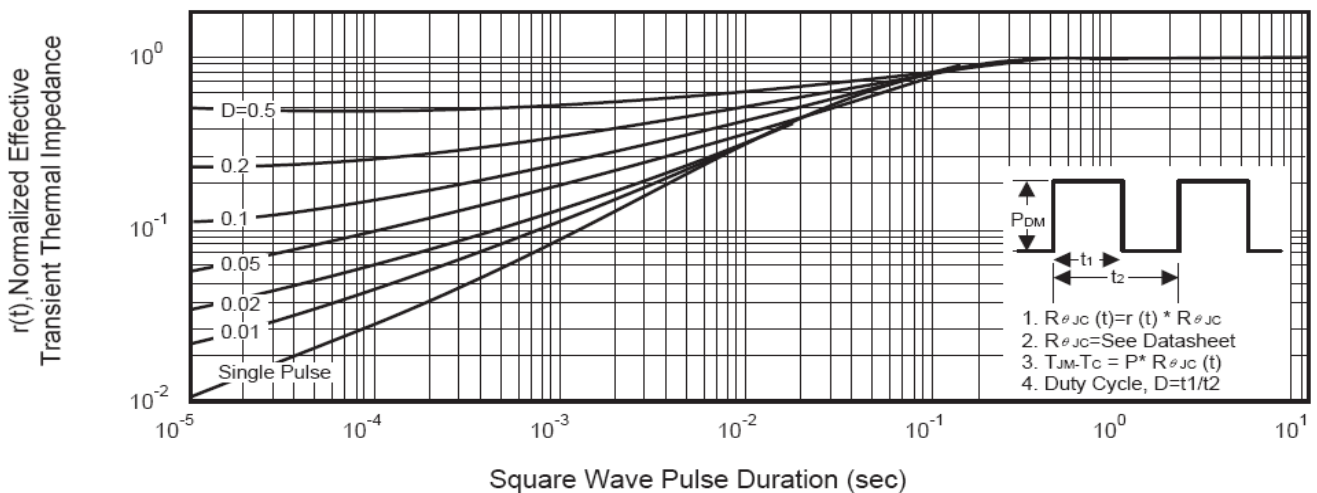

Transient Thermal Impedance Curve

TO-220 MECHANICAL DATA:

