

### FTD880 TRANSISTOR (NPN)

#### FEATURES

- Low Frequency Power Amplifier
- Complement to FTB834

#### MAXIMUM RATINGS (T<sub>a</sub>=25°C unless otherwise noted)

Symbol	Parameter	Value	Unit
V <sub>CBO</sub>	Collector- Base Voltage	60	V
V <sub>CEO</sub>	Collector- Emitter Voltage	60	V
V <sub>EBO</sub>	Emitter- Base Voltage	7	V
I <sub>c</sub>	Collector Current - Continuous	3	A
P <sub>c</sub>	Collector Power Dissipation	1.5	W
T <sub>J</sub>	Junction Temperature	150	°C
T <sub>stg</sub>	Storage Temperature	- 55- 150	°C

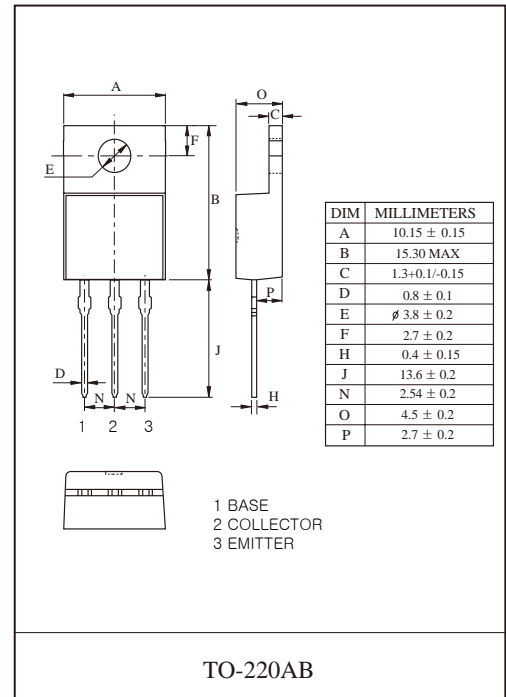

#### ELECTRICAL CHARACTERISTICS (T<sub>a</sub>=25°C unless otherwise specified)

Parameter	Symbol	Test conditions	Min	Typ	Max	Unit
Collector-base breakdown voltage	V <sub>(BR)CBO</sub>	I <sub>C</sub> =100μA, I <sub>E</sub> =0	60			V
Collector-emitter breakdown voltage	V <sub>(BR)CEO</sub>	I <sub>C</sub> =50mA, I <sub>B</sub> =0	60			V
Emitter-base breakdown voltage	V <sub>(BR)EBO</sub>	I <sub>E</sub> =100μA, I <sub>C</sub> =0	7			V
Collector cut-off current	I <sub>CBO</sub>	V <sub>CB</sub> =60V, I <sub>E</sub> =0			100	μA
Emitter cut-off current	I <sub>EBO</sub>	V <sub>EB</sub> =7V, I <sub>C</sub> =0			100	μA
DC current gain	h <sub>FE</sub>	V <sub>CE</sub> =5V, I <sub>C</sub> =500mA	60		300	
Collector-emitter saturation voltage	V <sub>CE(sat)</sub>	I <sub>C</sub> =3A, I <sub>B</sub> =300mA			1	V
Base-emitter voltage	V <sub>BE</sub>	I <sub>C</sub> =0.5A, V <sub>CE</sub> = 5V			1	V
Transition Frequency	f <sub>T</sub>	V <sub>CE</sub> =5 V, I <sub>C</sub> =500mA		3		MHz
Collector output capacitance	C <sub>ob</sub>	V <sub>CB</sub> =10V, I <sub>E</sub> =0, f=1MHz		70		pF
Turn on time	t <sub>on</sub>	I <sub>B1</sub> =- I <sub>B2</sub> =0.2A, I <sub>C</sub> =2A V <sub>CC</sub> =30V, PW=20μs		0.8		μs
Storage time	t <sub>s</sub>			1.5		μs
Fall time	t <sub>f</sub>			0.8		μs

#### CLASSIFICATION OF h<sub>FE</sub>

Rank	O	Y	GR
Range	60- 120	100- 200	150- 300

## Typical Characteristics

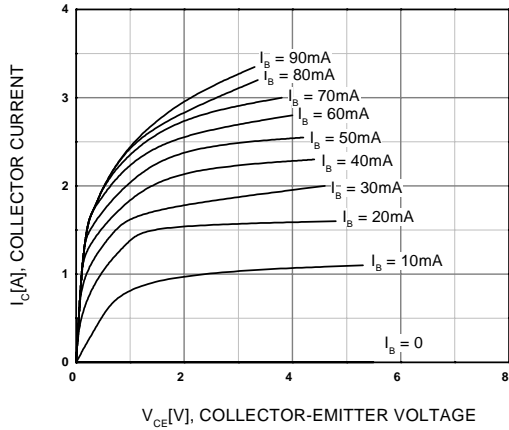

Figure 1. Static Characteristic

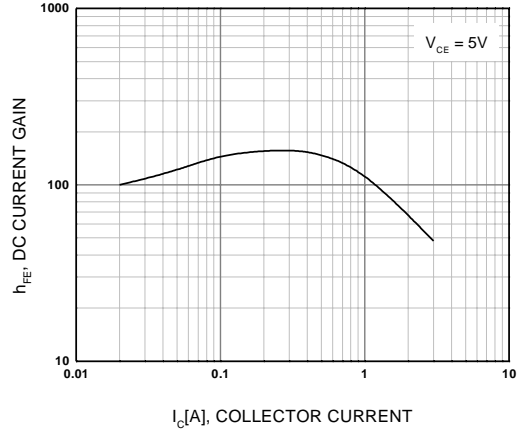

Figure 2. DC current Gain

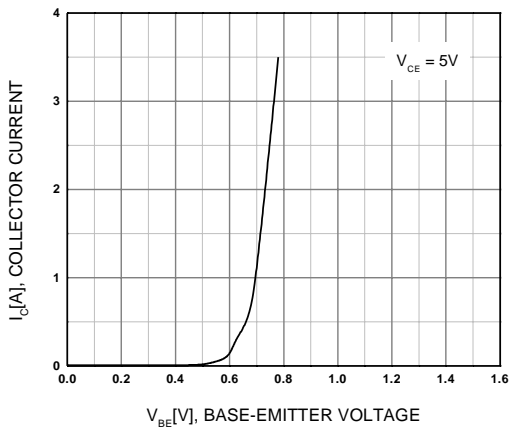

Figure 3. Base-Emitter On Voltage

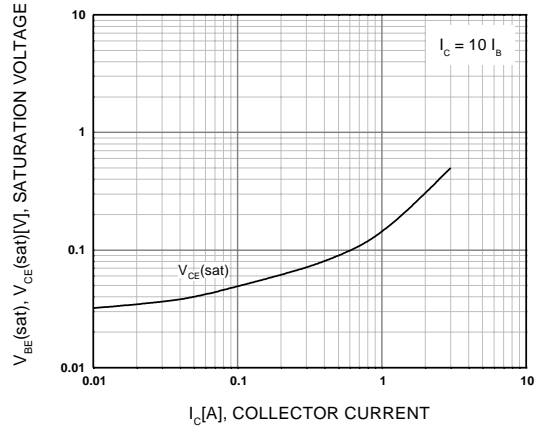

Figure 4. Collector-Emitter Saturation Voltage vs Collector Current

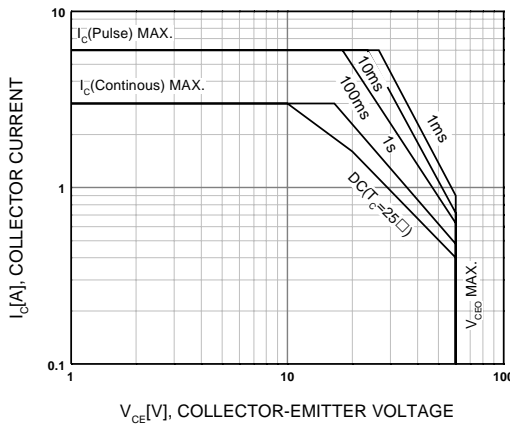

Figure 5. Safe Operating Area

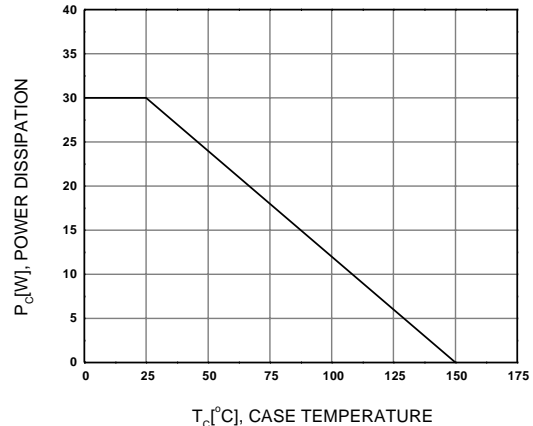

Figure 6. Power Derating