

### ● Features

1. Current transfer ratio: 50–600%(at condition  $I_F=5\text{mA}$ ,  $V_{CE}=5\text{V}$ )
2. High isolation voltage between input and output ( $V_{ISO}=3750\text{Vrms}$ )
3. Compact 4 pin SSOP
4. Pb free and RoHS compliant
5. CQC approval  
UL approval  
VDE approval  
CE approval

### ● Description

The JC357 device consist of an infrared emitting diode, optically coupled to a phototransistor detector encapsulated with green compound.

Length of lead pin: 2.54mm

### ● Applications:

- DC-DC converters
- Programmable controllers
- Telecommunication equipments
- Single transmission between circuits of different potentials and impedances

### ● Dimension:

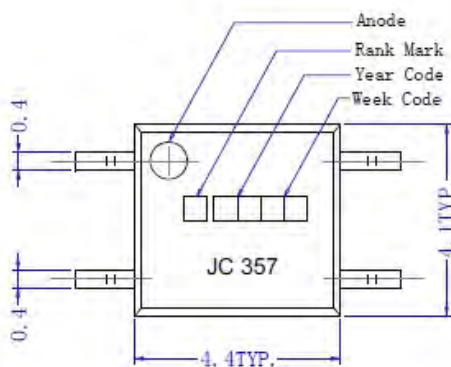

PIN NO. AND INTERNAL CONNECTION DIAGRAM

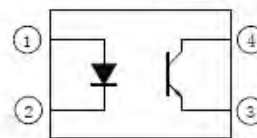

- |           |             |
|-----------|-------------|
| 1 Anode   | 3 Emitter   |
| 2 Cathode | 4 Collector |

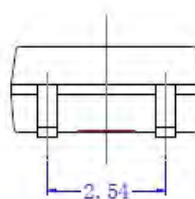
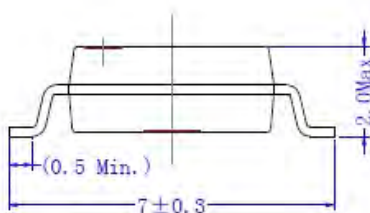

● Electrical Characteristics (Ta=25°C unless specified other wise)

Parameter		Symbol	Condition	Min	Typ.	Max	Unit
Input	Forward Voltage	V <sub>F</sub>	I <sub>F</sub> =20mA	---	1.2	1.4	V
	Reverse Current	I <sub>R</sub>	V <sub>R</sub> =4V	---	---	10	uA
	Input Capacitance	C <sub>t</sub>	V=0, f=1KHz	---	30	250	pF
Output	Collector-Emitter dark current	I <sub>CEO</sub>	V <sub>CE</sub> =20V, I <sub>F</sub> =0	---	---	100	nA
	Collector-Emitter breakdown voltage	BV <sub>CEO</sub>	I <sub>C</sub> =0.1mA I <sub>F</sub> =0	80	---	---	V
	Emitter-Collector breakdown voltage	BV <sub>ECO</sub>	I <sub>E</sub> =10 μ A I <sub>F</sub> =0	7	---	---	V
	Collector current	I <sub>C</sub>	I <sub>F</sub> =5mA	4	---	30	mA
	*2 Current transfer ratio	CTR	V <sub>CE</sub> =5V	80	---	600	%
	Saturation voltage	V <sub>CE(sat)</sub>	I <sub>F</sub> =20mA I <sub>C</sub> = 1mA	---	0.1	0.2	V
	Isolation resistor	R <sub>iso</sub>	DC 500V 40~60%R. H.	5×10 <sup>10</sup>	---	---	Ω
	Capacitance	C <sub>f</sub>	V=0, f=1MHz	---	0.6	1	pF
	cut-off frequency	f <sub>c</sub>	V <sub>CE</sub> =5V, I <sub>C</sub> =2mA R <sub>L</sub> =100 Ω, -3dB	---	80	---	kHz
	Rise time	t <sub>r</sub>	V <sub>CE</sub> =2V, I <sub>C</sub> =2mA	---	4	18	us
Fall time	t <sub>f</sub>	R <sub>L</sub> =100 Ω	---	3	18	us	

\*1 :  $CTR = I_C / I_F \times 100\%$

● CTR range

BIN range	Min (%)	Max (%)
A	80	160
B	130	260
C	200	400
D	300	600
A or B or C or D	80	600

Test condition at: I<sub>F</sub>=5mA, V<sub>CE</sub>=5V, Ta=25°C.

● Absolute Maximum Ratings ( $T_a=25^\circ\text{C}$ )

Parameter		Symbol	Rating	Unit
Input	Forward current	$I_F$	50	mA
	Reverse voltage	$V_R$	6	V
	Power dissipation	$P_D$	70	mW
Output	Collector-Emitter breakdown voltage	$V_{CE0}$	80	V
	Emitter-Collector breakdown voltage	$V_{ECO}$	7	
	Collector current	$I_C$	50	mA
	Collector power dissipation	$P_C$	150	mW
Total power dissipation		$P_{tot}$	200	mW
*1 Isolation voltage		$V_{iso}$	3750	$V_{rms}$
Operating temperature		$T_{opr}$	-55 to +110	°C
Storage temperature		$T_{stg}$	-55 to +125	
*2 Soldering temperature		$T_{sol}$	260	

Notes:

1. AC for one minute, R. H. =40~60%.

Test methods:

- 1); In this test, pins 1&2 are shorted together, and pins 3&4 are shorted together.
- 2); For 10 seconds.

● Typical performance curves:

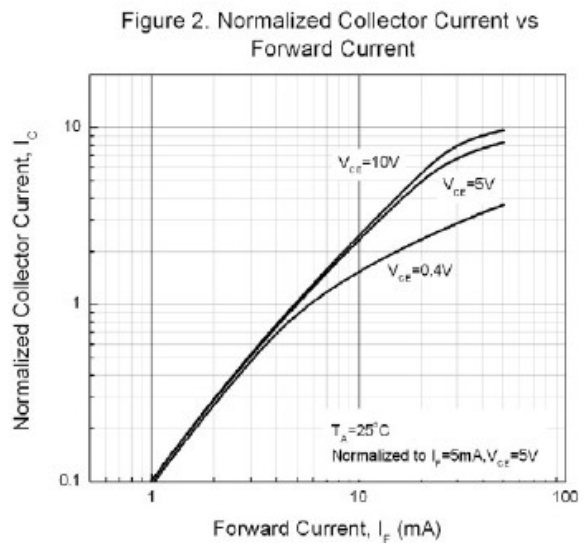
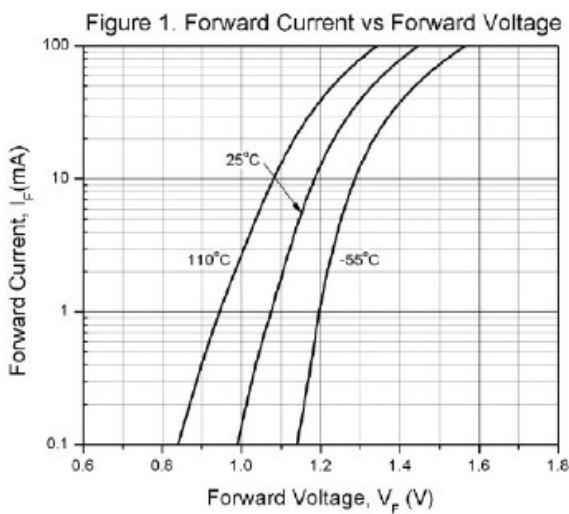

● Typical performance curves:

Figure 3. Normalized Current Transfer Ratio vs Forward Current

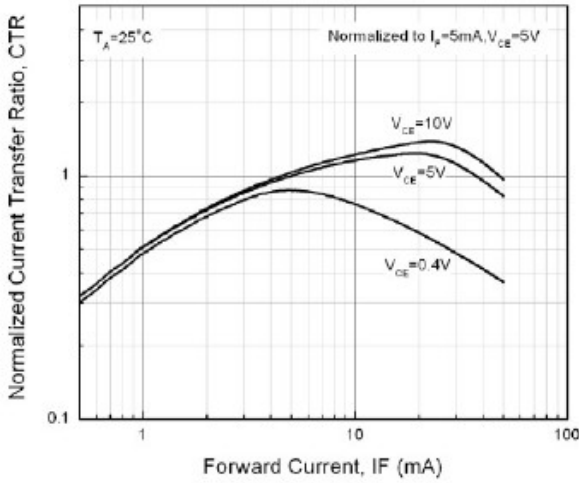

Figure 4. Normalized Collector Current vs Ambient Temperature

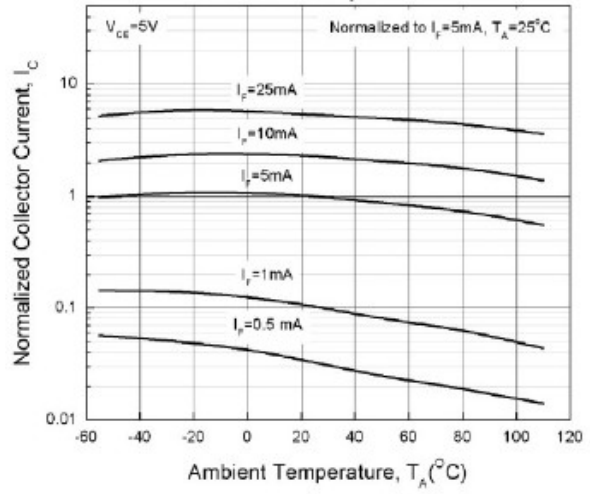

Figure 5. Collector Current vs Collector-Emitter Voltage

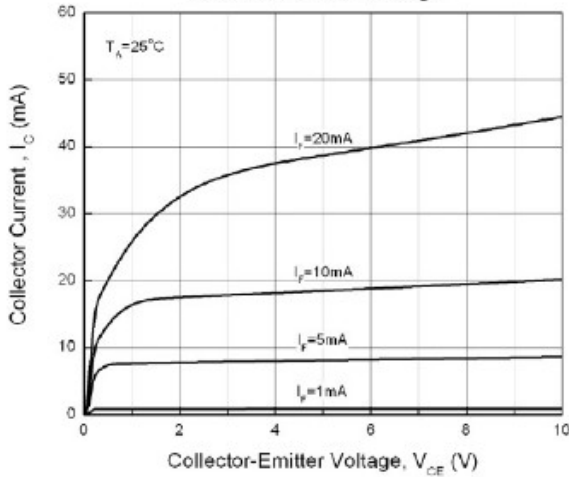

Figure 6. Collector Current vs Collector-Emitter Voltage

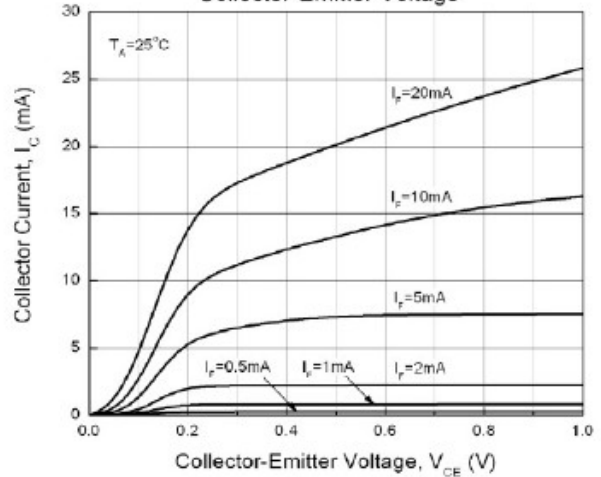

Figure 7. Collector Dark Current vs Ambient Temperature

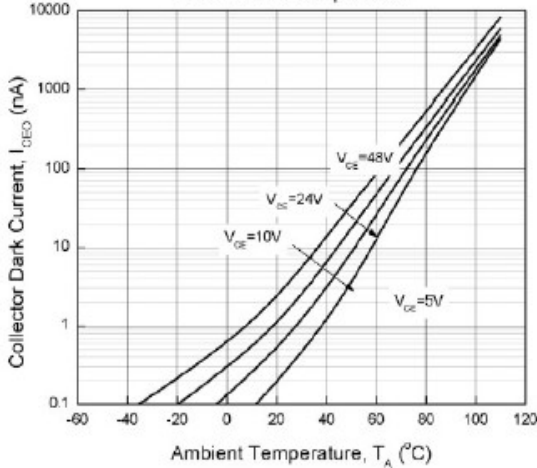
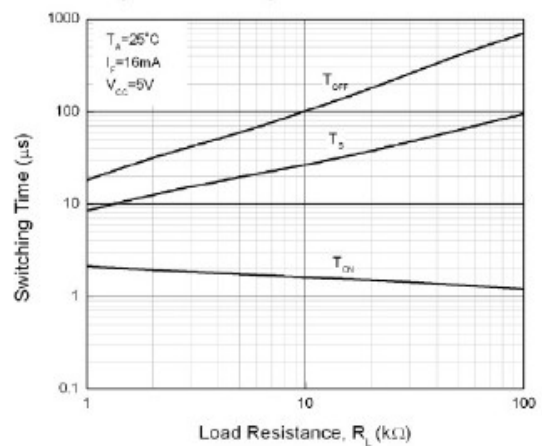
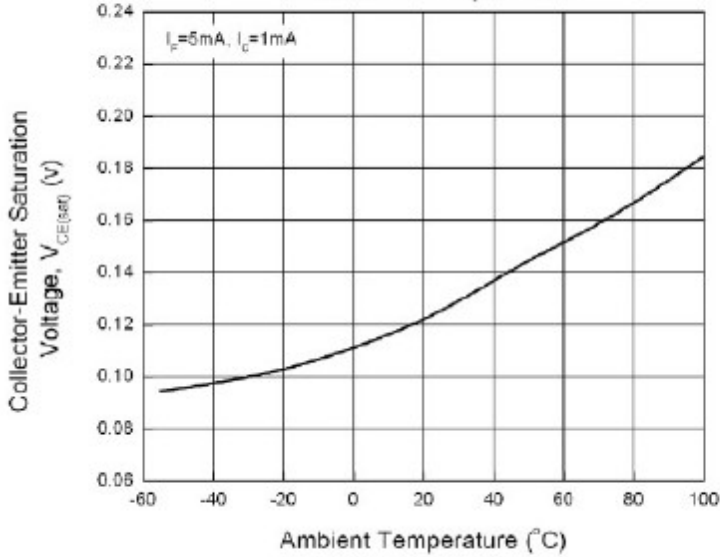

Figure 8. Switching Time vs Load Resistance



- Typical performance curves:

Figure 9. Collector-Emitter Saturation Voltage vs Ambient Temperature



Test Circuit for Response Time

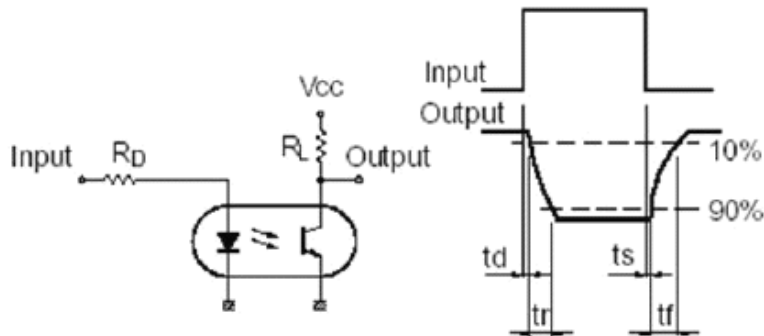

Test Circuit for Frequency Response

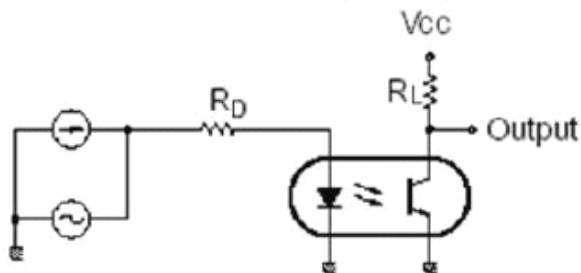

● Installation and dimension recommendation:

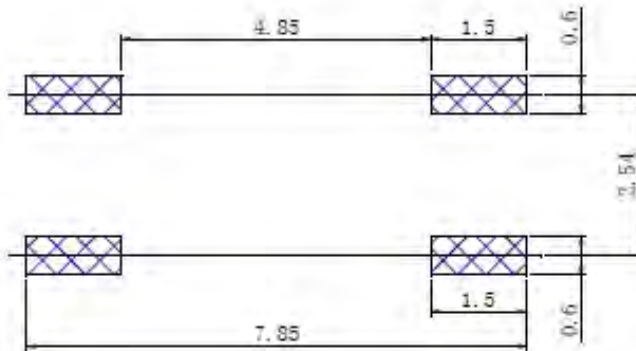

● Packaging

A. Tape & Reel Packing Specifications:

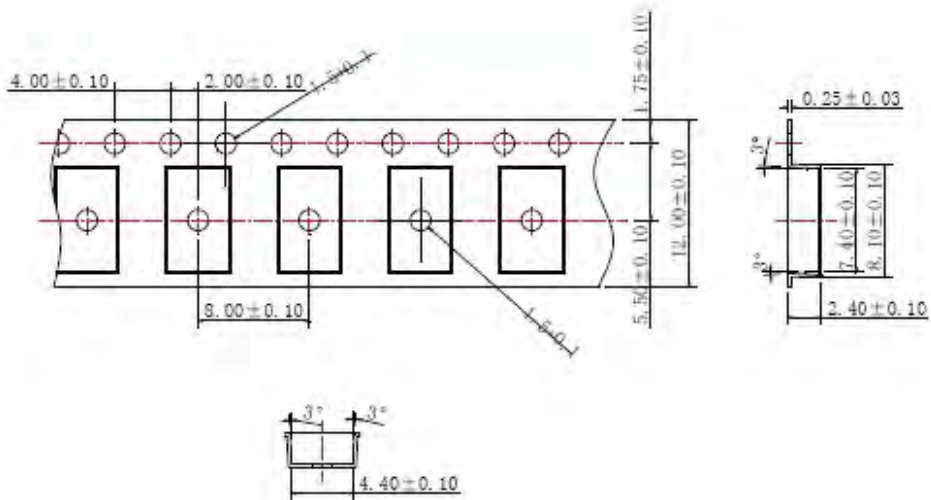

B. Tape dimensions: 1KP/Reel

