

TFS4083

Description

The TFS4083 is designed for use in VHF & UHF oscillators and VHF mixer in tuner of a TV receiver.

Features

- High transition frequency. ($f_T = 3.2\text{GHz}$, typ. @ $V_{CE}=10\text{V}$, $I_C=10\text{mA}$, $f=500\text{MHz}$)
- Very low capacitance. ($C_{ob} = 0.8\text{pF}$, typ. @ $V_{CB}=10\text{V}$, $f=1\text{MHz}$)
- Small $R_{bb'}$ - C_c and high gain. ($R_{bb'}$ - $C_c = 4\text{ps}$, typ. @ $V_{CB}=10\text{V}$, $I_C=10\text{mA}$, $f=31.8\text{MHz}$)
- Small NF. ($NF = 3.5\text{dB}$, typ. @ $V_{CE}=12\text{V}$, $I_C=2\text{mA}$, $f=200\text{MHz}$, $R_g=50$)

Symbol

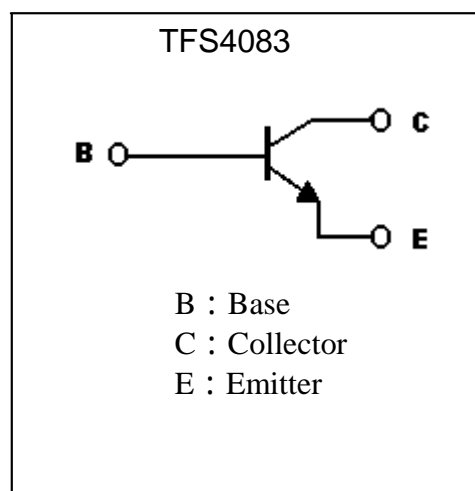

Outline

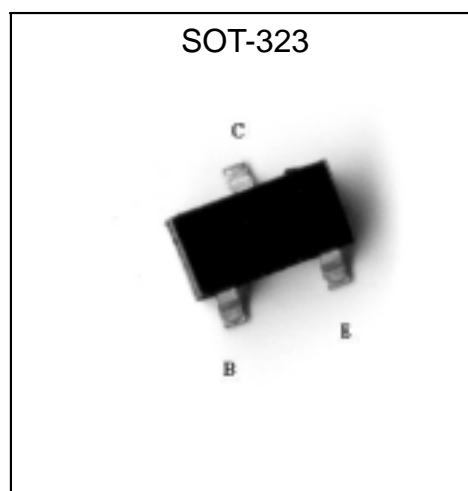

Absolute Maximum Ratings (Ta=25°C)

Parameter	Symbol	Limits	Unit
Collector-Base Voltage	V_{CBO}	20	V
Collector-Emitter Voltage	V_{CEO}	11	V
Emitter-Base Voltage	V_{EBO}	3	V
Collector Current	I_C	50	mA
Power Dissipation	P_d	200	mW
Junction Temperature	T_j	150	°C
Storage Temperature	T_{stg}	-55~+150	°C



Characteristics (Ta=25°C)

Symbol	Min.	Typ.	Max.	Unit	Test Conditions
BV _{CB0}	20	-	-	V	I _C =10μA
BV _{CEO}	11	-	-	V	I _C =1mA
BV _{EBO}	3	-	-	V	I _E =10μA
I _{CB0}	-	-	0.5	μA	V _{CB} =10V
I _{EBO}	-	-	0.5	μA	V _{EB} =2V
*V _{CE(sat)}	-	-	0.5	V	I _C =10mA, I _B =5mA
*h _{FE}	82	-	180	-	V _{CE} =10V, I _C =5mA
f _T	1.4	3.2	-	GHz	V _{CE} =10V, I _C =10mA, f=500MHz
C _{ob}	-	0.8	1.5	pF	V _{CB} =10V, I _E =0A, f=1MHz
R _{bb} '-C _C	-	4	12	ps	V _{CB} =10V, I _C =10mA, f=31.8MHz
NF	-	3.5	-	dB	V _{CE} =12V, I _C =2mA, f=200MHz, R _g =50

*Pulse Test : Pulse Width ≤380μs, Duty Cycle≤2%

Ordering Information

Device	Package	Shipping	Marking
TFS4083	SOT-323	3000 pcs / Tape & Reel	1D



Characteristic Curves

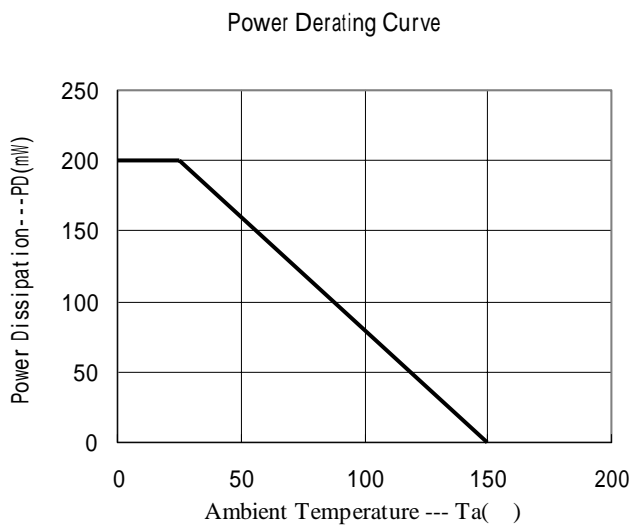
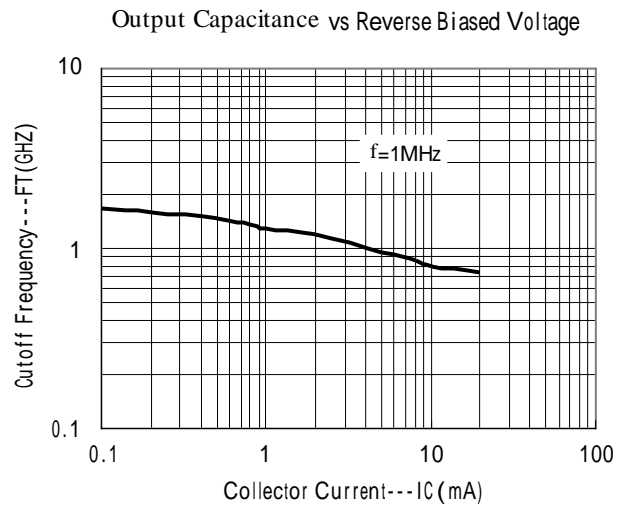
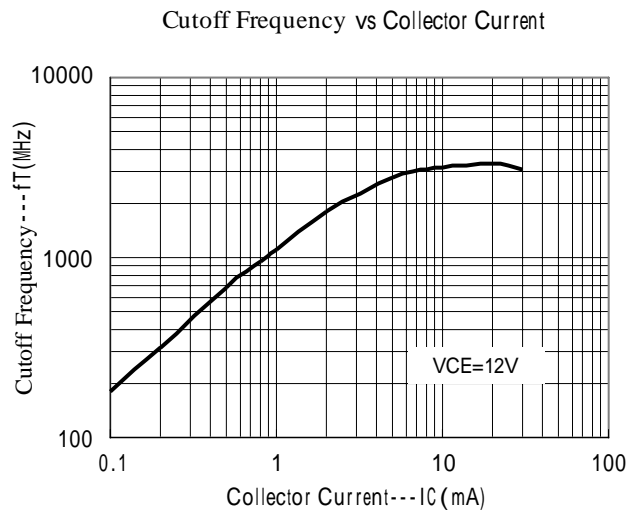
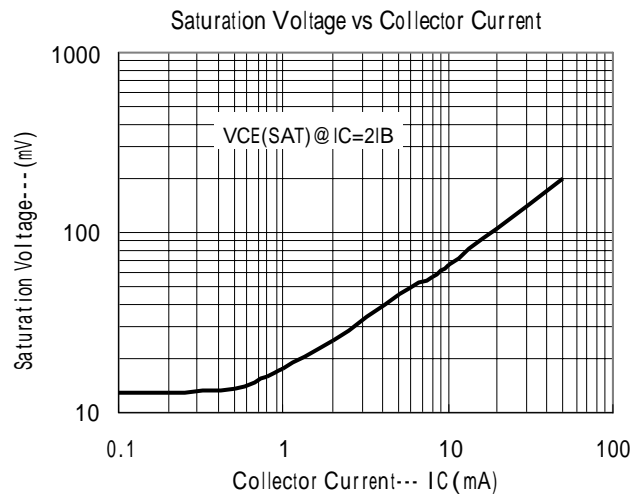
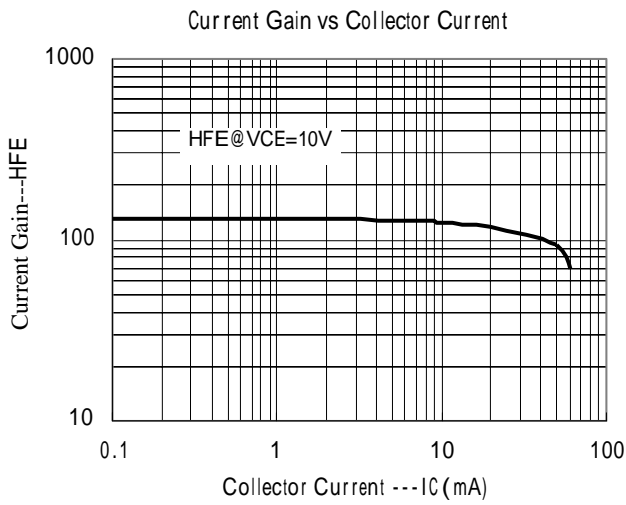

SOT-323 Dimension

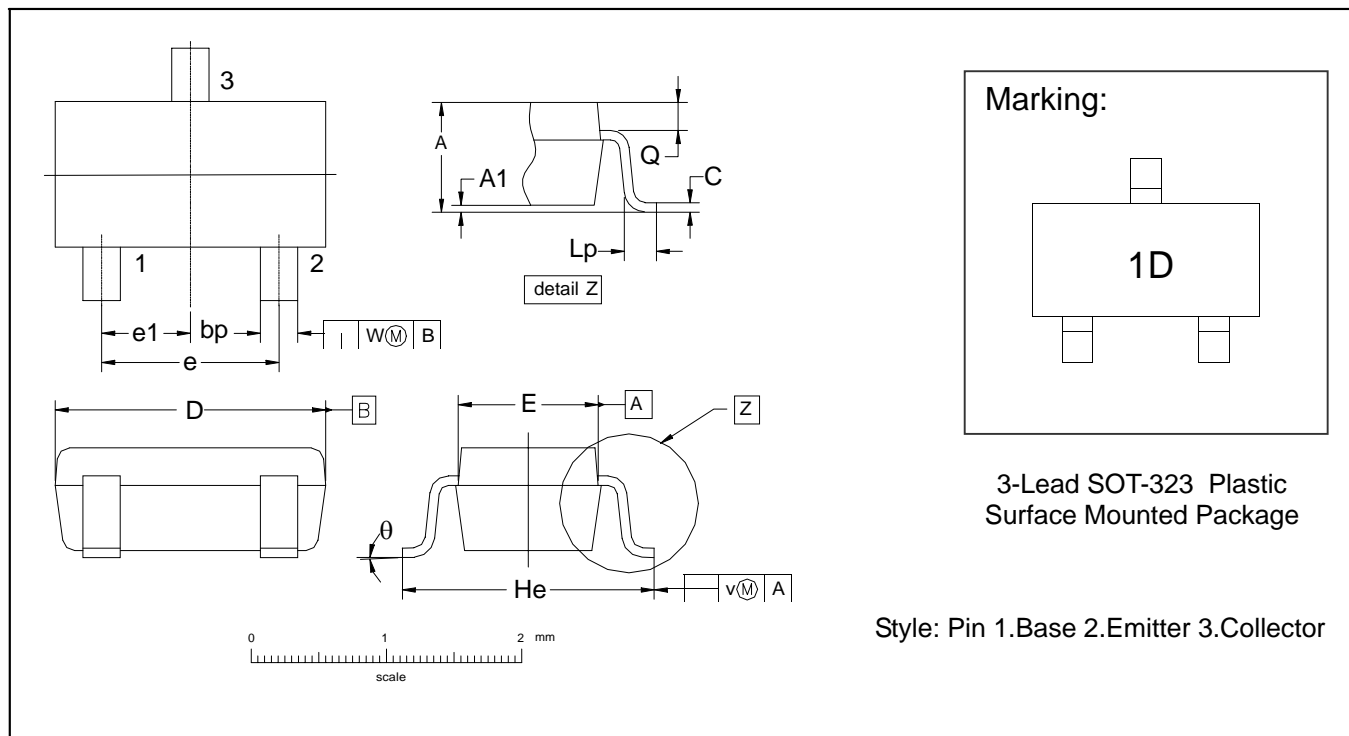

*: Typical

DIM	Inches		Millimeters		DIM	Inches		Millimeters	
	Min.	Max.	Min.	Max.		Min.	Max.	Min.	Max.
A	0.0315	0.0433	0.80	1.10	e1	0.0256	-	0.65	-
A1	0.0000	0.0039	0.00	0.10	He	0.0787	0.0886	2.00	2.25
bp	0.0118	0.0157	0.30	0.40	Lp	0.0059	0.0177	0.15	0.45
C	0.0039	0.0098	0.10	0.25	Q	0.0051	0.0091	0.13	0.23
D	0.0709	0.0866	1.80	2.20	v	0.0079	-	0.2	-
E	0.0453	0.0531	1.15	1.35	w	0.0079	-	0.2	-
e	0.0512	-	1.3	-	(-	-	10°	0°

Notes: 1.Controlling dimension: millimeters.

2.Maximum lead thickness includes lead finish thickness, and minimum lead thickness is the minimum thickness of base material.

3.If there is any question with packing specification or packing method, please contact your local Tin Far sales office.

Material:

Lead: 42 Alloy ; solder plating

Mold Compound: Epoxy resin family, flammability solid burning class: UL94V-0

Important Notice:

- All rights are reserved. Reproduction in whole or in part is prohibited without the prior written approval of Tin Far.
- Tin Far reserves the right to make changes to its products without notice.
- Tin Far **semiconductor products are not warranted to be suitable for use in Life-Support Applications, or systems.**
- Tin Far assumes no liability for any consequence of customer product design, infringement of patents, or application assistance.