

TFN2059

Description

The TFN2059 is designed for using in VHF & UHF oscillators and VHF mixer in tuner of a TV receiver.

Features

- High transition frequency. ($f_T = 1.0\text{GHz}$, $T_{YP. @ V_{CB}=10V, I_C=10mA, f=200MHz}$)
- Very low capacitance. ($C_{ob} = 1.4\text{ pF}$, $T_{YP. @ V_{CB}=10V, f=1MHz}$)
- Small $r_{bb'}-C_c$ and high gain. ($r_{bb'}-C_c = 8ps$, $T_{YP. @ V_{CB}=10V, I_c=10mA, f=31.8MHz}$)
- Small NF. ($NF = 5.5dB$, $T_{YP. @ V_{CE}=12V, I_c=2mA, f=200MHz, R_g=50ohm}$)

Equivalent Circuit

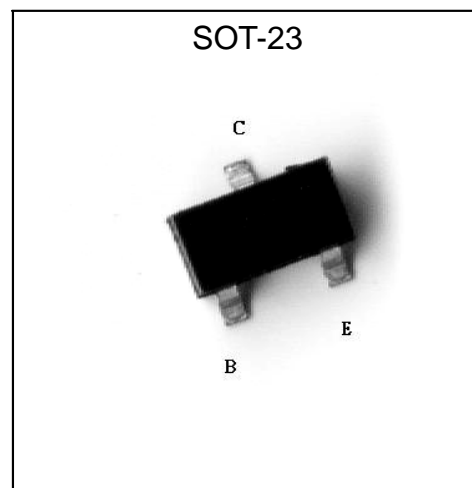
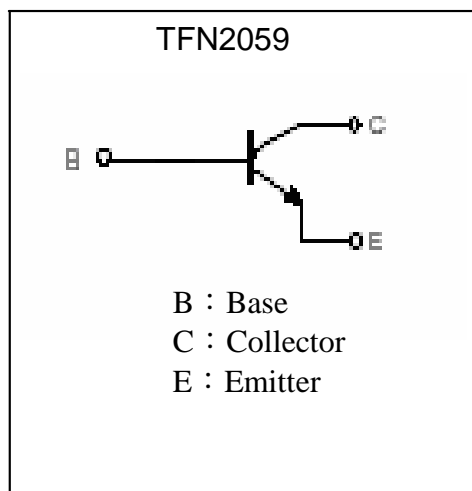

Absolute Maximum Ratings (Ta=25°C)

Parameter	Symbol	Limits	Unit
Collector-Base Voltage	VCBO	25	V
Collector-Emitter Voltage	VCEO	18	V
Emitter-Base Voltage	VEBO	3	V
Collector Current	IC	50	mA
Power Dissipation	Pd	225	mW
Junction Temperature	Tj	150	°C
Storage Temperature	Tstg	-55~+150	°C

Characteristics (Ta=25°C)

Symbol	Min.	Typ.	Max.	Unit	Test Conditions
BVCBO	25	-	-	V	IC=10uA
BVCEO	18	-	-	V	IC=1mA
BVEBO	3	-	-	V	IC=10uA
ICBO	-	-	0.5	uA	VCB=10V
IEBO	-	-	0.5	uA	VEB=2V
*VCE(sat)	-	0.1	0.5	V	IC=20mA, IB=4mA
*hFE	52	-	270		VCE=10V, IC=10mA
fT	600	1000	-	MHz	VCB=10V, IC=10mA, f=200MHz
Cob	-	1.4	2.0	pF	VCB=10V, IE=0A, f=1MHz
Rbb'-Cc	-	8	15	pF	VCB=10V, IC=10mA, f=31.8MHz
NF	-	5.5	-	dB	VCE=12V, IC=2mA, f=200MHz, Rg=50ohm

*Pulse Test : Pulse Width ≤380us, Duty Cycle≤2%

Classification Of hFE

Rank	K	P	Q
Range	52~120	82~180	120~270

Characteristic Curves

Current Gain vs Collector Current

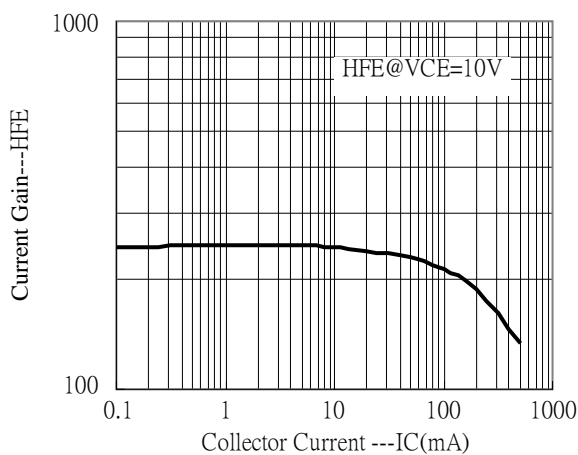

Saturation Voltage vs Collector Current

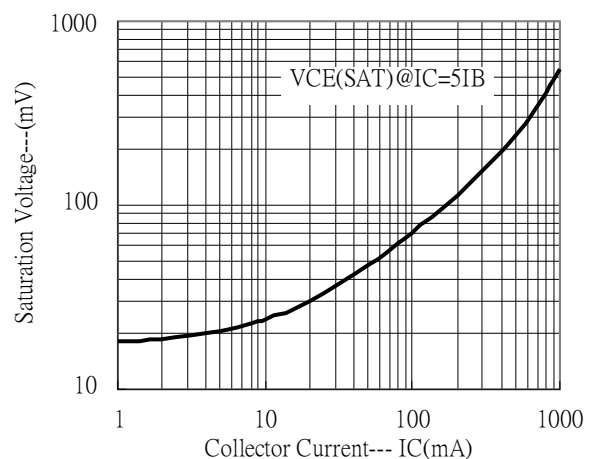

Saturation Voltage vs Collector Current

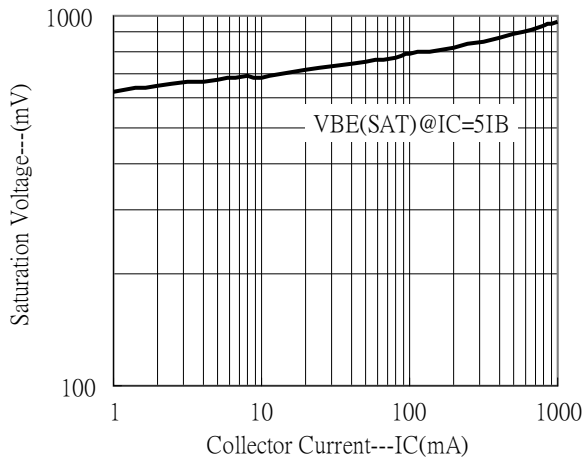

Cutoff Frequency vs Collector Current

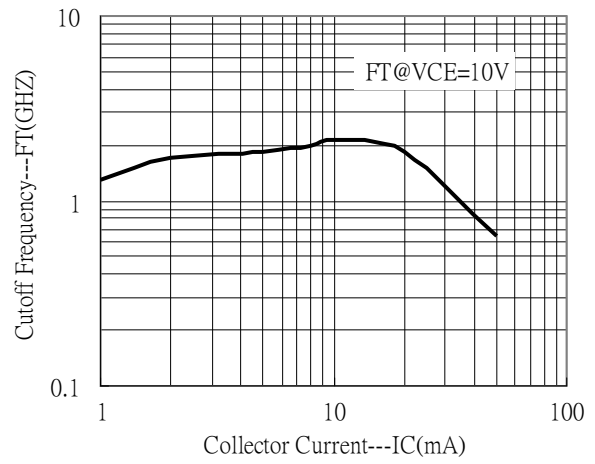

PD - Ta

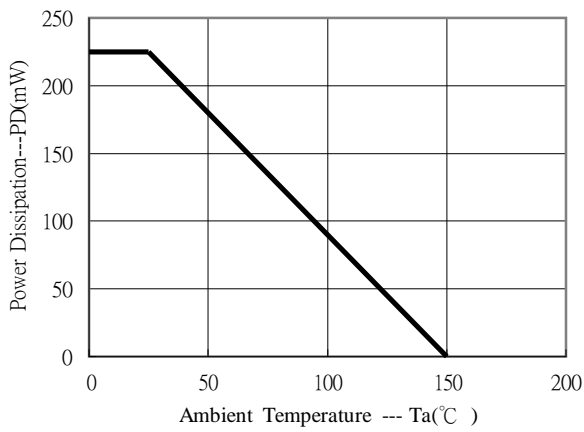

SOT-23 Dimension

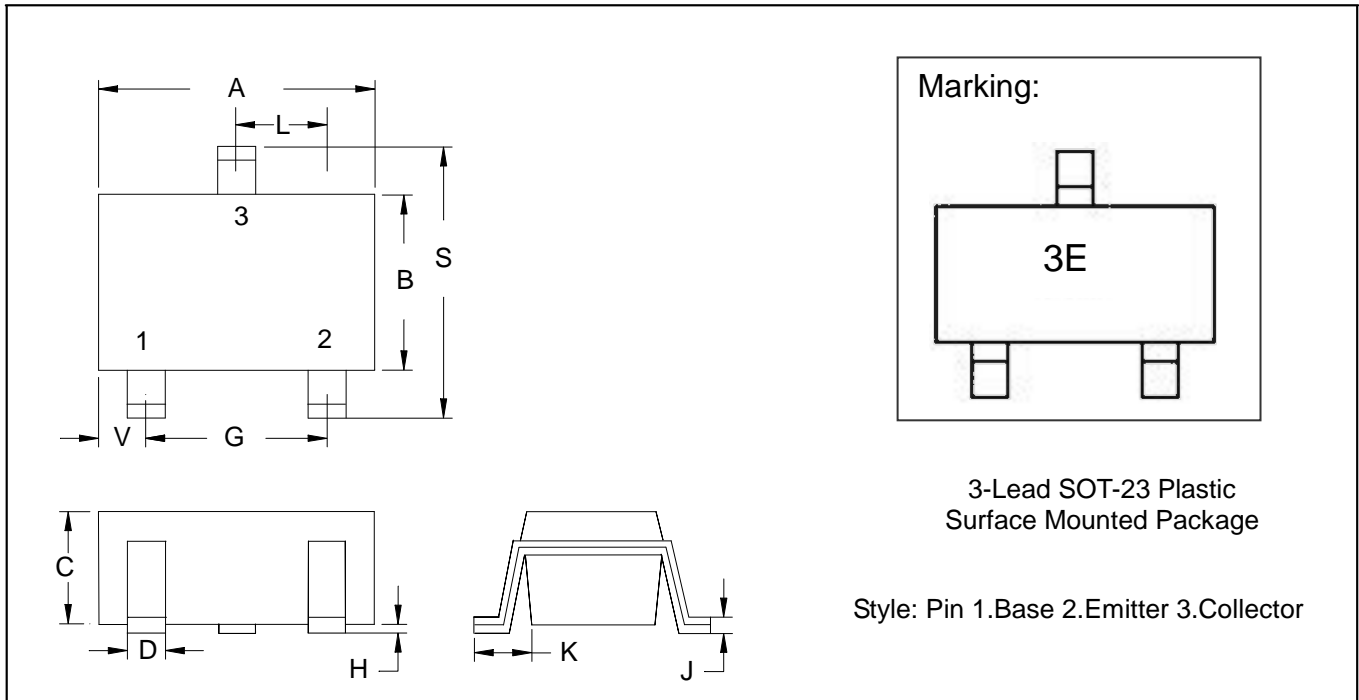

*: Typical

DIM	Inches		Millimeters		DIM	Inches		Millimeters	
	Min.	Max.	Min.	Max.		Min.	Max.	Min.	Max.
A	0.1102	0.1204	2.80	3.04	J	0.0034	0.0070	0.085	0.177
B	0.0472	0.0630	1.20	1.60	K	0.0128	0.0266	0.32	0.67
C	0.0335	0.0512	0.89	1.30	L	0.0335	0.0453	0.85	1.15
D	0.0118	0.0197	0.30	0.50	S	0.0830	0.1083	2.10	2.75
G	0.0669	0.0910	1.70	2.30	V	0.0098	0.0256	0.25	0.65
H	0.0005	0.0040	0.013	0.10					

- Notes: 1.Dimension and tolerance based on our Spec. dated Feb. 18,2002.
 2.Controlling dimension: millimeters.
 3.Maximum lead thickness includes lead finish thickness, and minimum lead thickness is the minimum thickness of base material.
 4.If there is any question with packing specification or packing method, please contact your local Tin Far sales office.

Material:

- Lead: 42 Alloy ; solder plating
- Mold Compound: Epoxy resin family, flammability solid burning class: UL94V-0

Important Notice:

- All rights are reserved. Reproduction in whole or in part is prohibited without the prior written approval of Tin Far.
- Tin Far reserves the right to make changes to its products without notice.
- Tin Far **semiconductor products are not warranted to be suitable for use in Life-Support Applications, or systems.**
- Tin Far assumes no liability for any consequence of customer product design, infringement of patents, or application assistance.