

TFN2411

40V 600mA NPN Transistor

Description

- The TFN2411 is designed for using in driver stage of AF amplifier and general purpose switching application.
- High $I_{C(Max)}$, $I_{C(Max)} = 0.6A$.
- Low $V_{CE(sat)}$, Typ. $V_{CE(sat)} = 0.4V$ at $I_C/I_B = 500mA/50mA$.
Optimal for low Voltage operation.
- Complementary to TFN1036.
- Pb-free package

Symbol

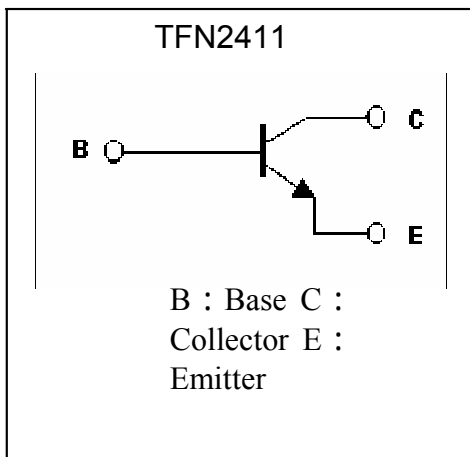

Outline

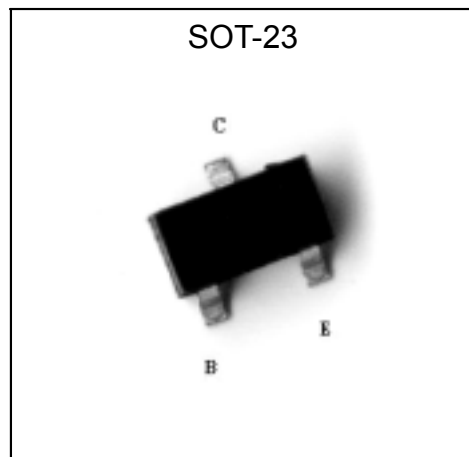

Absolute Maximum Ratings (Ta=25°C)

Parameter	Symbol	Limits	Unit
Collector-Base Voltage	V_{CBO}	75	V
Collector-Emitter Voltage	V_{CEO}	40	V
Emitter-Base Voltage	V_{EBO}	6	V
Collector Current	I_C	0.6	A
Power Dissipation (Ta=25°C)	P_D	225 (Note)	mW
Power Dissipation (Tc=25°C)	P_D	560	mW
Thermal Resistance, Junction to Ambient	$R_{\theta JA}$	556 (Note)	°C/W
Thermal Resistance, Junction to Case	$R_{\theta JC}$	223	°C/W
Junction Temperature	T_j	150	°C
Storage Temperature	T_{stg}	-55~+150	°C

Note : Free air condition



Characteristics (Ta=25°C)

Symbol	Min.	Typ.	Max.	Unit	Test Conditions
BV _{CBO}	75	-	-	V	I _C =10μA
BV _{CEO}	40	-	-	V	I _C =10mA
BV _{EBO}	6	-	-	V	I _E =10μA
I _{CBO}	-	-	10	nA	V _{CB} =60V
I _{CEX}	-	-	10	nA	V _{CE} =60V, V _{BE} =-3V
I _{EBO}	-	-	10	nA	V _{EB} =3V
*V _{CE(sat)1}	-	-	0.5	V	I _C =380mA, I _B =10mA
*V _{CE(sat)2}	-	-	0.4	V	I _C =150mA, I _B =15mA
*V _{CE(sat)3}	-	-	0.75	V	I _C =500mA, I _B =50mA
*V _{BE(sat)1}	0.75	-	0.95	V	I _C =150mA, I _B =15mA
*V _{BE(sat)2}	-	-	1.2	V	I _C =500mA, I _B =50mA
*h _{FE1}	85	-	-		V _{CE} =1V, I _C =0.1mA
*h _{FE2}	90	-	-		V _{CE} =1V, I _C =1mA
*h _{FE3}	95	-	-		V _{CE} =1V, I _C =10mA
*h _{FE4}	100	-	300		V _{CE} =1V, I _C =150mA
*h _{FE5}	40	-	-		V _{CE} =2V, I _C =500mA
f _T	300	-	-	MHz	V _{CE} =5V, I _C =20mA, f=100MHz
C _{ob}	-	6	-	pF	V _{CB} =5V, f=1MHz

*Pulse Test: Pulse Width ≤380μs, Duty Cycle≤2%

Ordering Information

Device	Package	Shipping	Marking
TFN2411	SOT-23 (Pb-free)	3000 pcs / Tape & Reel	2X

Recommended Storage Condition:

Temperature : ≤ 30 °C

Humidity : ≤ 60% RH



Characteristic Curves

Current Gain vs Collector Current

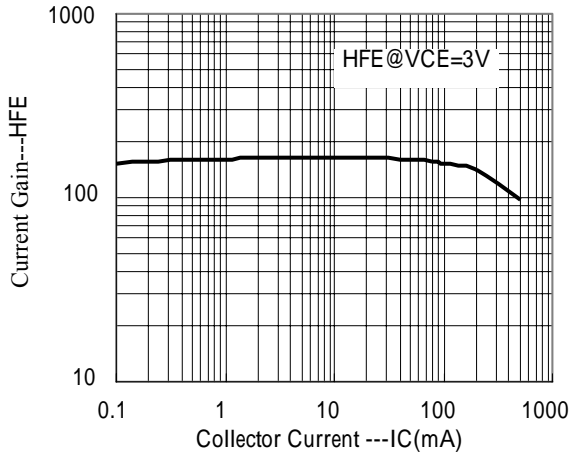

Saturation Voltage vs Collector Current

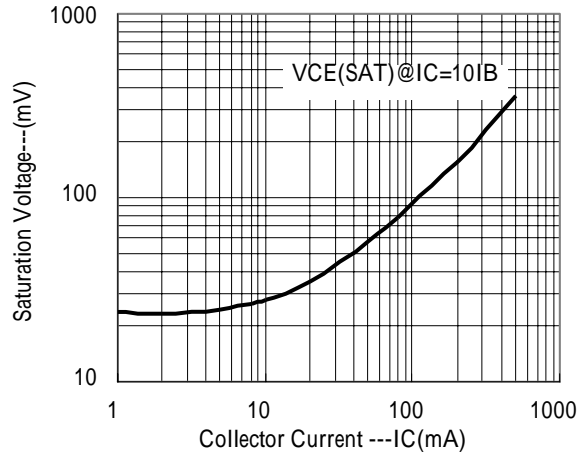

Saturation Voltage vs Collector Current

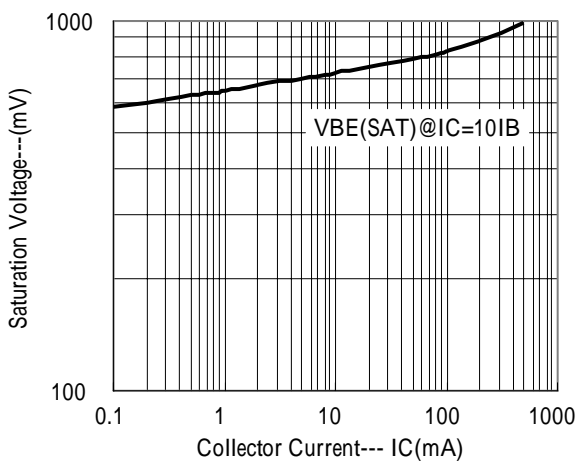

Cutoff Frequency vs Collector Current

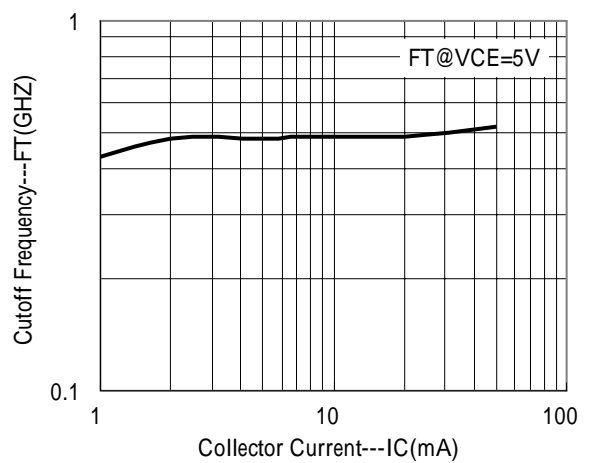

Power Derating Curve

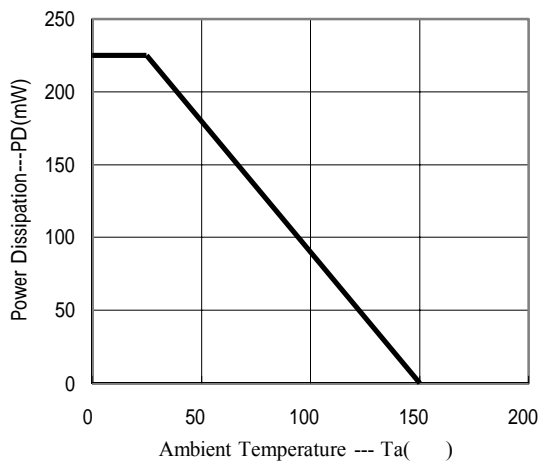



Reel Dimension

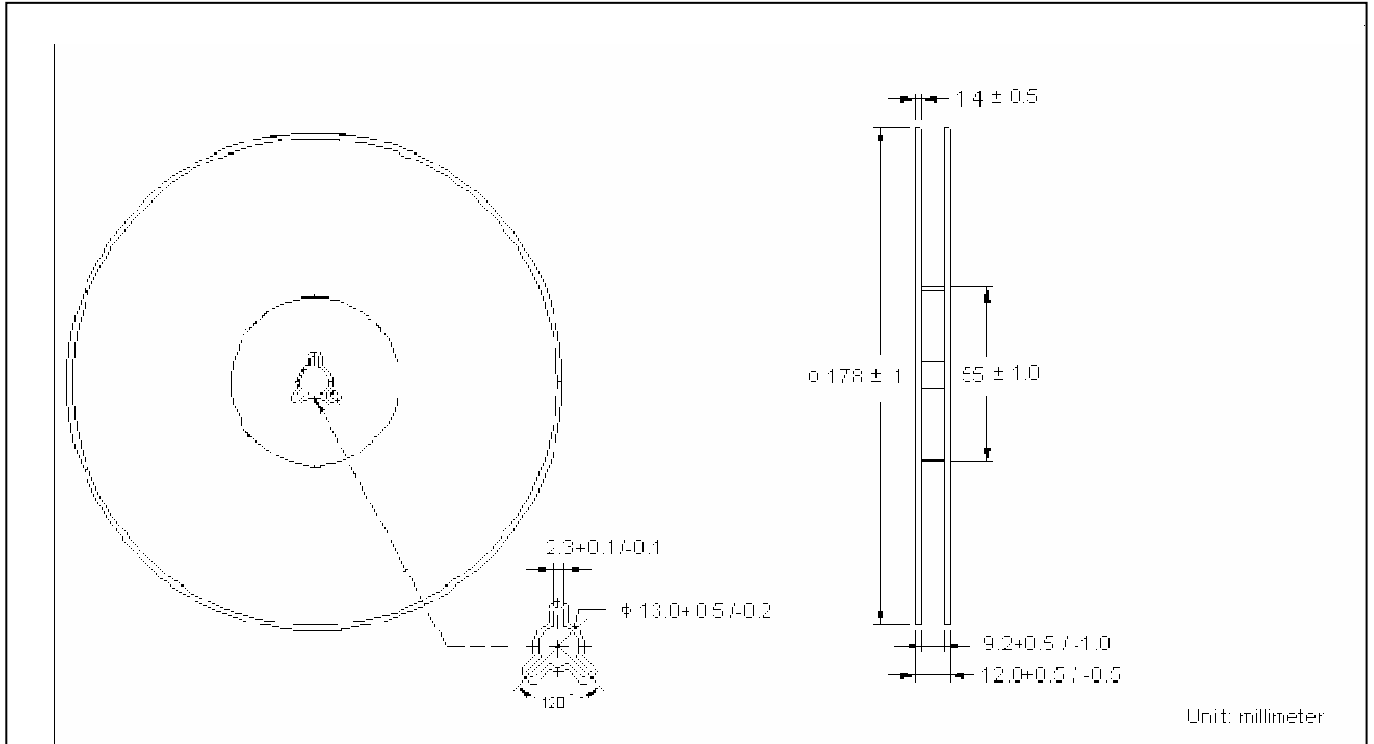

Carrier Tape Dimension

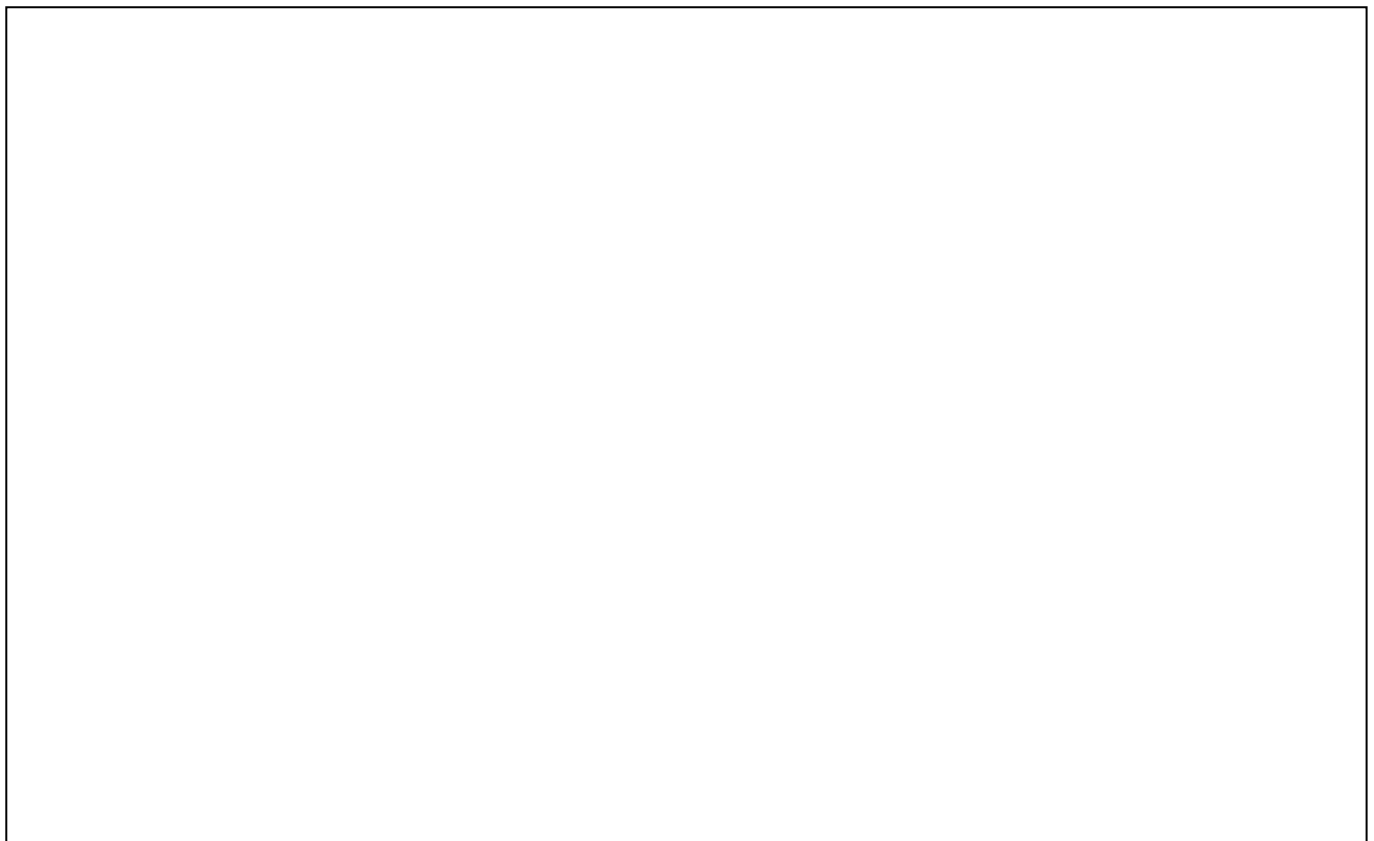



Recommended wave soldering condition

Product	Peak Temperature	Soldering Time
Pb-free devices	260 +0/-5 °C	5 +1/-1 seconds

Recommended temperature profile for IR reflow

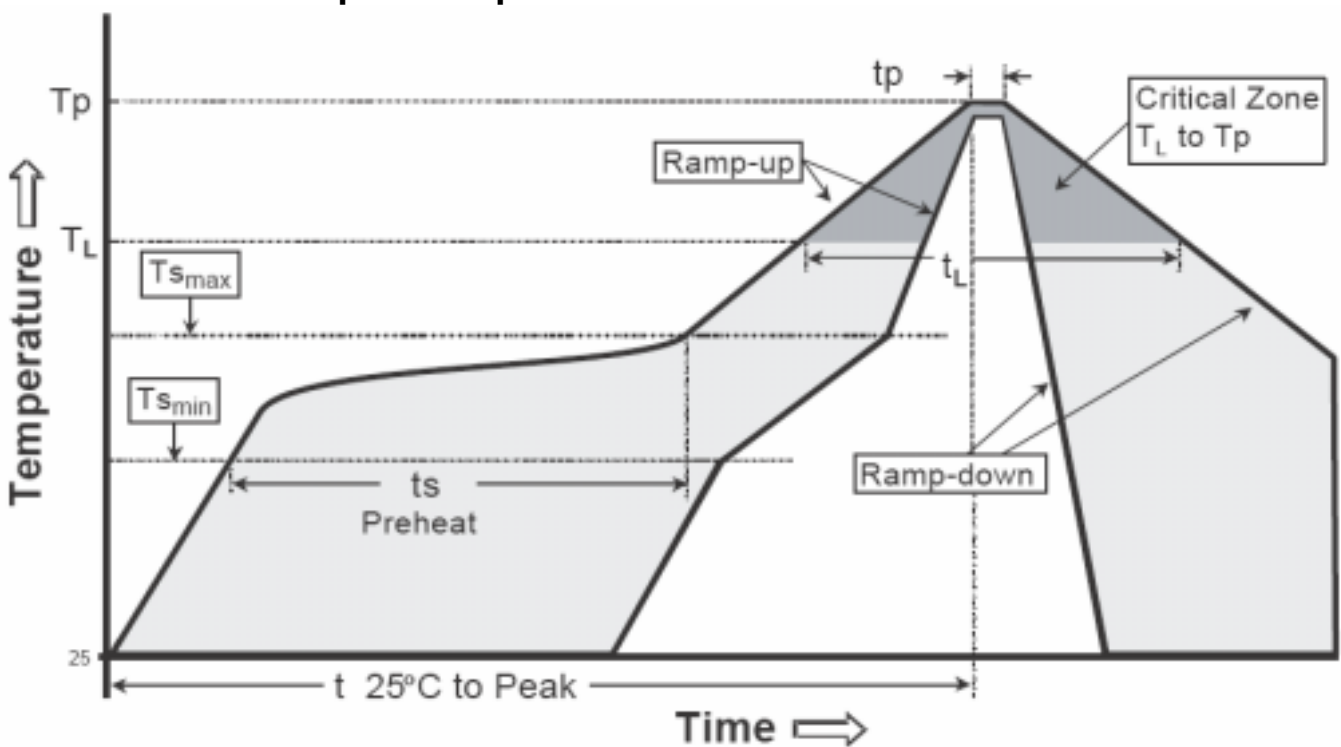

Profile feature	Sn-Pb eutectic Assembly	Pb-free Assembly
Average ramp-up rate (T _{smax} to T _p)	3°C/second max.	3°C/second max.
Preheat		
-Temperature Min(T _{s min})	100°C	150°C
-Temperature Max(T _{s max})	150°C	200°C
-Time(t _{s min} to t _{s max})	60-120 seconds	60-180 seconds
Time maintained above:		
-Temperature (T _L)	183°C	217°C
- Time (t _L)	60-150 seconds	60-150 seconds
Peak Temperature(T _P)	240 +0/-5 °C	260 +0/-5 °C
Time within 5°C of actual peak temperature(tp)	10-30 seconds	20-40 seconds
Ramp down rate	6°C/second max.	6°C/second max.
Time 25 °C to peak temperature	6 minutes max.	8 minutes max.

Note : All temperatures refer to topside of the package, measured on the package body surface.

SOT-23 Dimension

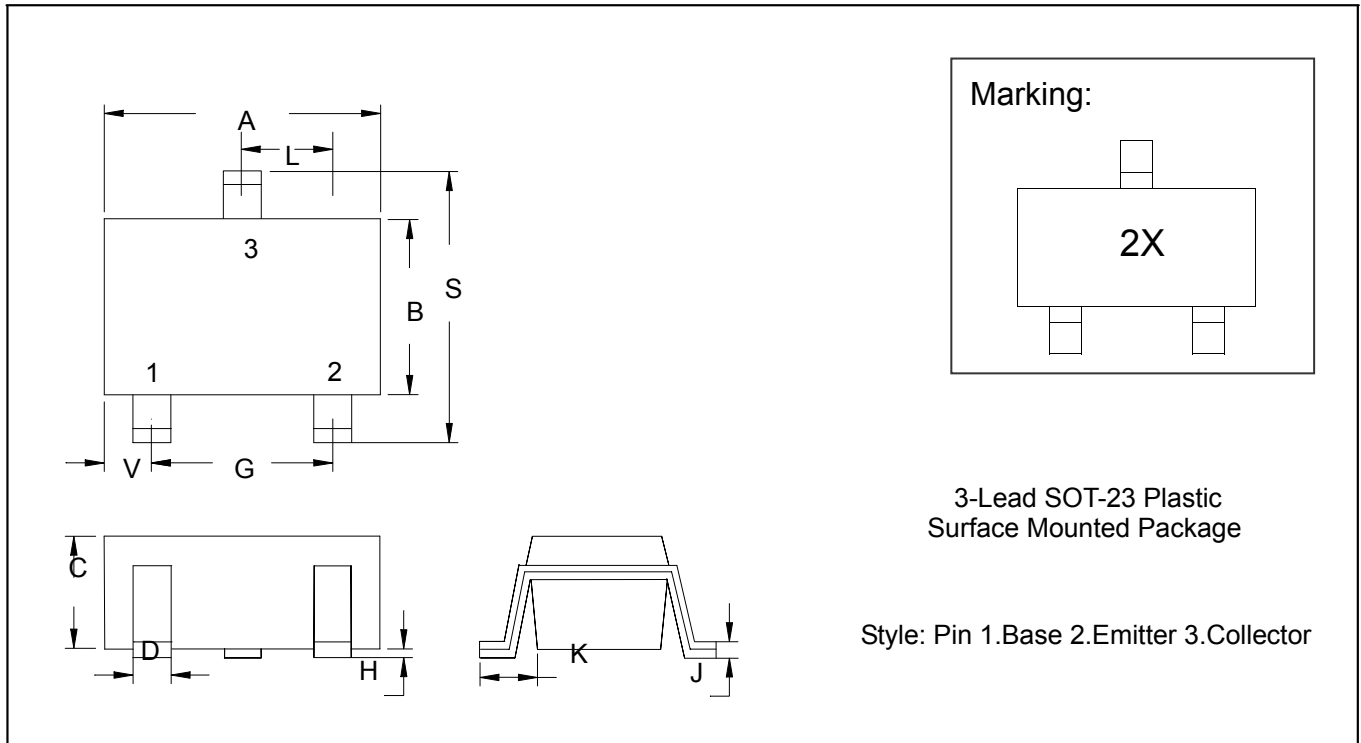

*: Typical

DIM	Inches		Millimeters		DIM	Inches		Millimeters	
	Min.	Max.	Min.	Max.		Min.	Max.	Min.	Max.
A	0.1102	0.1204	2.80	3.04	J	0.0034	0.0070	0.085	0.177
B	0.0472	0.0630	1.20	1.60	K	0.0128	0.0266	0.32	0.67
C	0.0335	0.0512	0.85	1.30	L	0.0335	0.0453	0.85	1.15
D	0.0118	0.0197	0.30	0.50	S	0.0830	0.1083	2.10	2.75
G	0.0669	0.0910	1.70	2.30	V	0.0098	0.0256	0.25	0.65
H	0.0005	0.0040	0.013	0.10					

Notes: 1.Controlling dimension: millimeters.

2.Maximum lead thickness includes lead finish thickness, and minimum lead thickness is the minimum thickness of base material.

3.If there is any question with packing specification or packing method, please contact your local Tin Far sales office.

Material:

- Lead: 42 Alloy ; pure tin plated
- Mold Compound: Epoxy resin family, flammability solid burning class: UL94V-0

Important Notice:

- All rights are reserved. Reproduction in whole or in part is prohibited without the prior written approval of Tin Far .
- Tin Far reserves the right to make changes to its products without notice.
- Tin Far **semiconductor products are not warranted to be suitable for use in Life-Support Applications, or systems.**
- Tin Far assumes no liability for any consequence of customer product design, infringement of patents, or application assistance.