

Small Signal Schottky (double) diodes

BAR40N3/BAR40AN3

BAR40CN3/BAR40SN3

Description

Planar silicon Schottky barrier diodes encapsulated in a SOT-23 small plastic SMD package. Single diodes and double diodes with different pinning are available.

Features

- Very small conduction losses
- Low forward voltage drop
- Small plastic SMD package
- Pb-free lead plating and halogen-free package

Applications

- Ultra high-speed switching
- Voltage clamping
- Protection circuits
- Blocking diodes

Pinning

Pin	Description			
	BAR40	BAR40A	BAR40C	BAR40S
1	A	K1	A1	A1
2	NC	K2	A2	K2
3	K	A1,A2	K1,K2	K1,A1

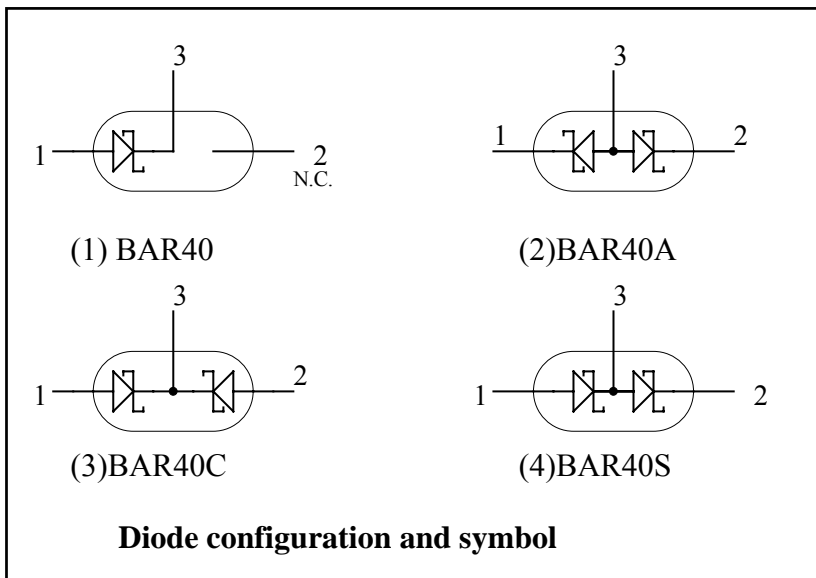

Outline

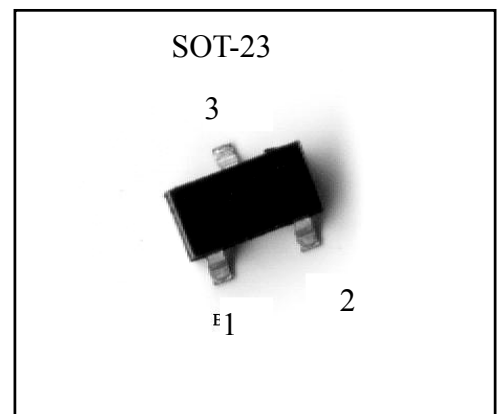

Marking:

Type	Marking Code
BAR40 N3	JV3
BAR40AN3	B6
BAR40CN3	5C
BAR40SN3	LD3



Absolute Maximum Ratings

- Maximum Temperatures
 Storage Temperature Tstg..... -65~+150 °C
 Operating Junction Temperature Tj-65~+150 °C
- Maximum Power Dissipation
 Total Power Dissipation (Ta=25°C) Ptot (Note) 350 mW
- Maximum Voltages and Currents (Ta=25°C)
 Repetitive Peak Reverse Voltage VRRM..... 40 V
 Continuous Forward Current IF 200 mA
 Repetitive Peak Forward Current(tp≤1s,duty cycle≤0.5)..... 300mA
 Non-repetitive Peak Forward Current (tp<10ms, sinusoidal) IFSM..... 600 mA

Note: for double diodes, Ptot is the total power dissipation of both diodes.

Characteristics (Ta=25°C)

Characteristic	Symbol	Condition	Min.	Max.	Unit
Reverse Breakdown Voltage	VBR	IR=100μA	40	-	V
Forward Voltage (Note 1)	VF(1)	IF=1mA	-	320	mV
	VF(2)	IF=40mA	-	500	mV
	VF(3)	IF=100mA	-	550	mV
Reverse Leakage Current (Note 2)	IR	VR=30V, Tj=25°C	-	200	nA
Diode Capacitance	CD	VR=1V, f=1MHz	-	10	pF
Reverse Recovery Time	trr	IF=IR=10mA RL=100Ω measured at IR=1mA	-	5	ns

Notes: 1.pulse test, tp=380μs,duty cycle<2%.
 2.pulse test, tp=5ms,duty cycle<2%.

Ordering Information

Device	Package	Shipping	Marking
BAR40N3-0-T1-G	SOT-23 (Pb-free lead plating and halogen-free package)	3000 pcs / Tape & Reel	JV3
BAR40AN3-0-T1-G			B6
BAR40CN3-0-T1-G			5C
BAR40SN3-0-T1-G			LD3

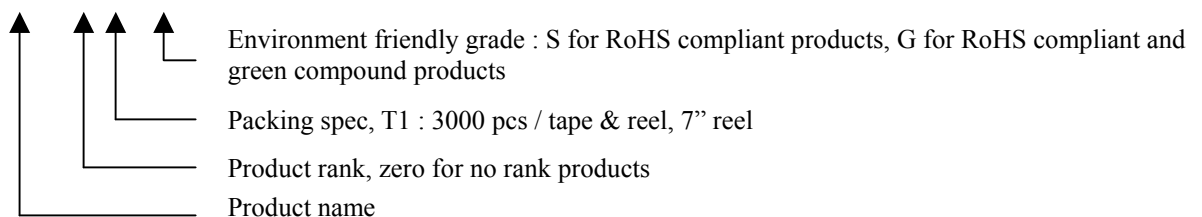

Typical Characteristics

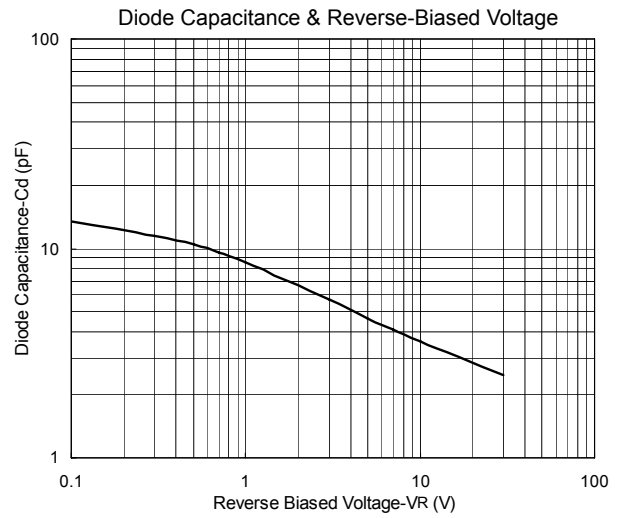
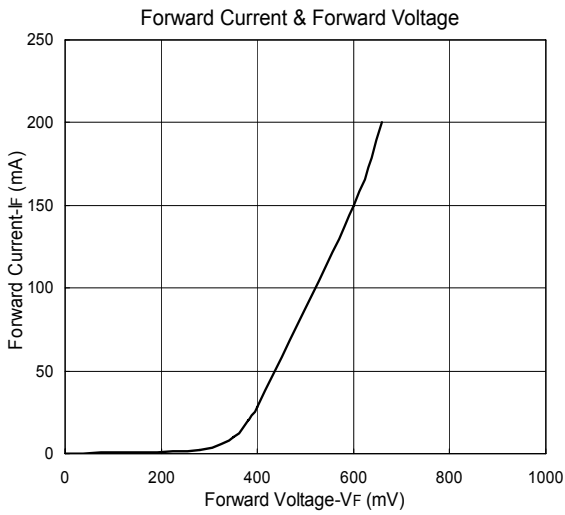

Recommended Footprint

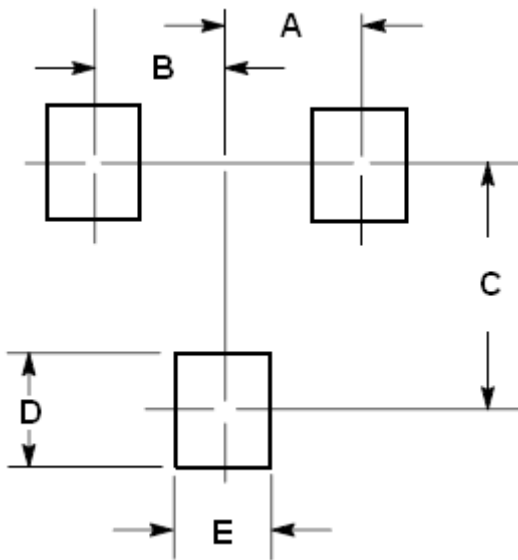

DIM	Inches	Millimeters
	Typ	Typ
A	0.039	1.0
B	0.039	1.0
C	0.079	2.0
D	0.035	0.9
E	0.031	0.8

Recommended wave soldering condition

Product	Peak Temperature	Soldering Time
Pb-free devices	260 +0/-5 °C	5 +1/-1 seconds

Recommended temperature profile for IR reflow

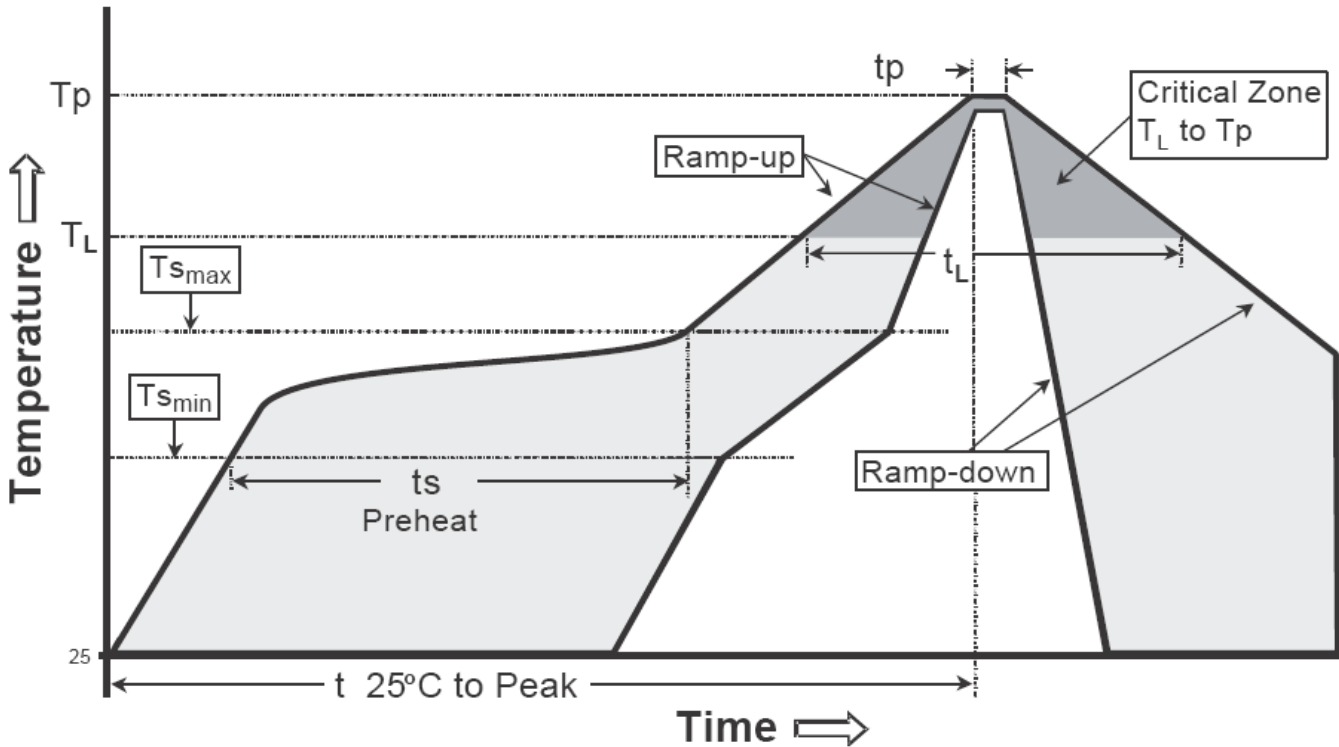

Profile feature	Sn-Pb eutectic Assembly	Pb-free Assembly
Average ramp-up rate (T _{smax} to T _p)	3°C/second max.	3°C/second max.
Preheat		
-Temperature Min(T _{s min})	100°C	150°C
-Temperature Max(T _{s max})	150°C	200°C
-Time(t _{s min} to t _{s max})	60-120 seconds	60-180 seconds
Time maintained above:		
-Temperature (T _L)	183°C	217°C
- Time (t _L)	60-150 seconds	60-150 seconds
Peak Temperature(T _P)	240 +0/-5 °C	260 +0/-5 °C
Time within 5°C of actual peak temperature(tp)	10-30 seconds	20-40 seconds
Ramp down rate	6°C/second max.	6°C/second max.
Time 25 °C to peak temperature	6 minutes max.	8 minutes max.

Note : All temperatures refer to topside of the package, measured on the package body surface.

Reel Dimension

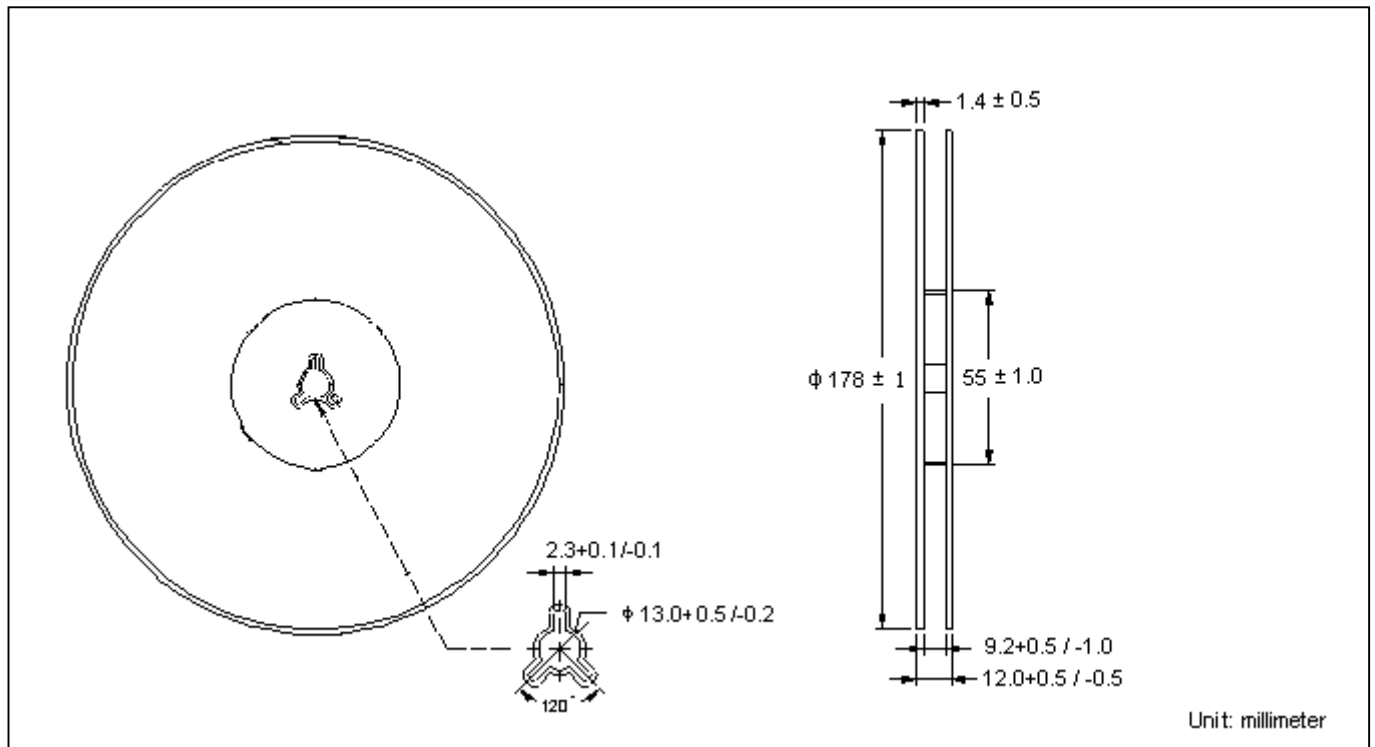

Carrier Tape Dimension

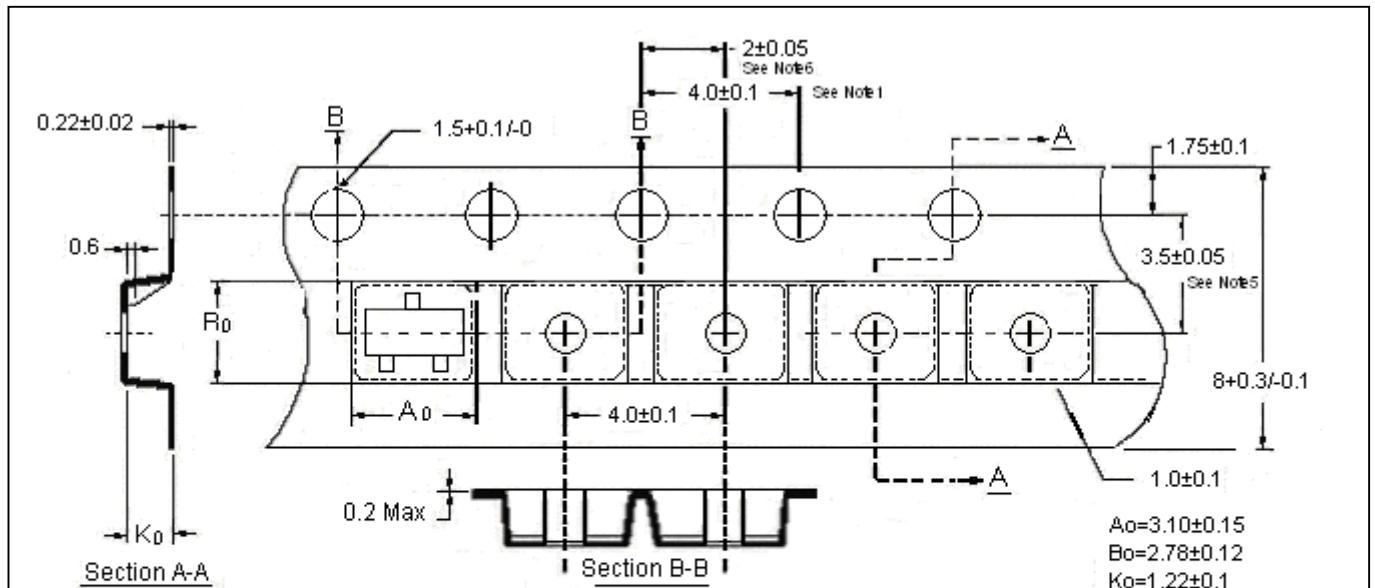

Notes:

1. 10 sprocket hole pitch cumulative tolerance ± 0.2 .
2. Camber not to exceed 1mm in 100mm.
3. Material : conductive Black Polystyrene.
4. A_0 & B_0 measured on a plane 0.3mm above the bottom of the pocket.
5. K_0 measured from a plane on the inside bottom of the pocket to the top surface of the carrier.
6. Pocket position relative to sprocket hole measured as true position of pocket, not pocket hole.

Unit : millimeter

SOT-23 Dimension

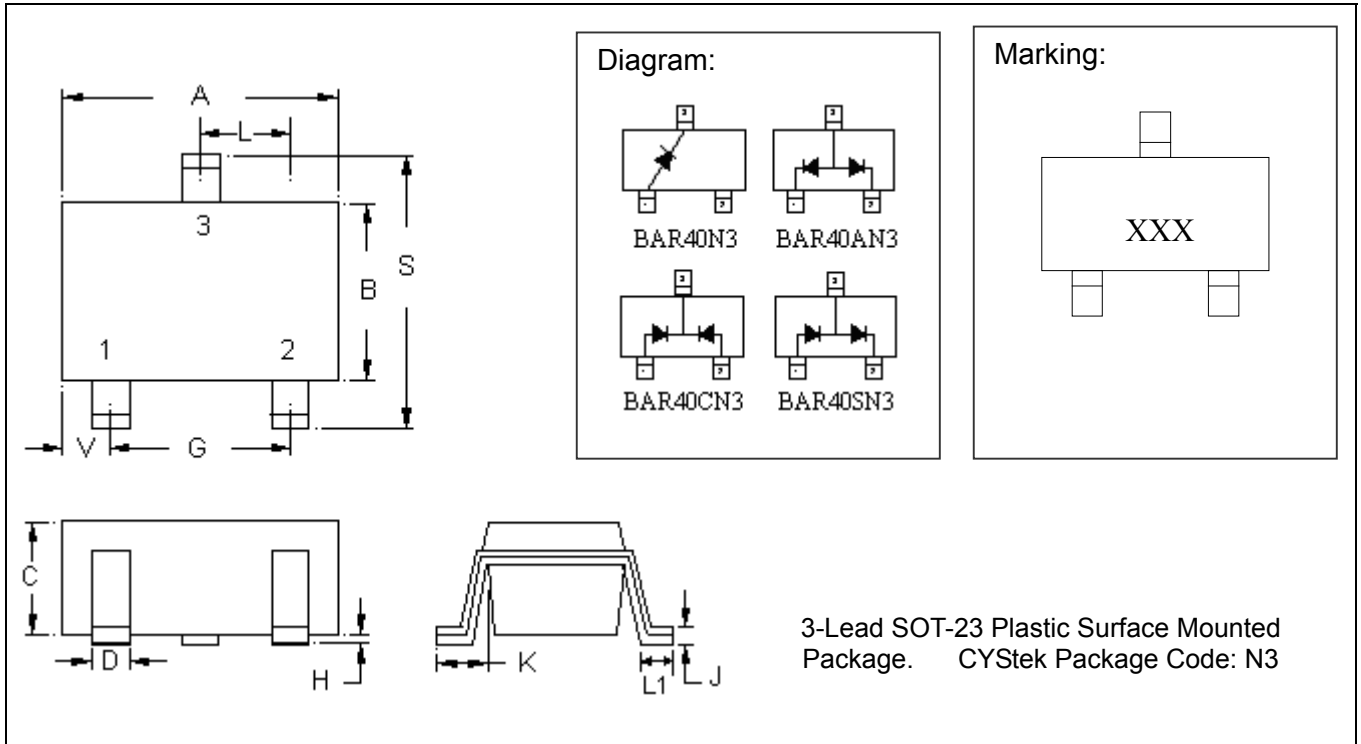

- BAR40 N3: Single Diode. (Marking Code JV3)
- BAR40AN3: Common Anode. (Marking Code B6)
- BAR40CN3: Common Cathode. (Marking Code 5C)
- BAR40SN3: Series Connected. (Marking Code LD3)

DIM	Inches		Millimeters		DIM	Inches		Millimeters	
	Min.	Max.	Min.	Max.		Min.	Max.	Min.	Max.
A	0.1102	0.1204	2.80	3.04	J	0.0032	0.0079	0.08	0.20
B	0.0472	0.0669	1.20	1.70	K	0.0118	0.0266	0.30	0.67
C	0.0335	0.0512	0.89	1.30	L	0.0335	0.0453	0.85	1.15
D	0.0118	0.0197	0.30	0.50	S	0.0830	0.1161	2.10	2.95
G	0.0669	0.0910	1.70	2.30	V	0.0098	0.0256	0.25	0.65
H	0.0000	0.0040	0.00	0.10	L1	0.0118	0.0197	0.30	0.50

Notes: 1.Controlling dimension: millimeters.
 2.Maximum lead thickness includes lead finish thickness, and minimum lead thickness is the minimum thickness of base material.
 3.If there is any question with packing specification or packing method, please contact your local CYStek sales office.

Material:

- Lead: Pure tin plated.
- Mold Compound: Epoxy resin family, flammability solid burning class: UL94V-0.

Important Notice:

- All rights are reserved. Reproduction in whole or in part is prohibited without the prior written approval of CYStek.
- CYStek reserves the right to make changes to its products without notice.
- CYStek **semiconductor products are not warranted to be suitable for use in Life-Support Applications, or systems.**
- CYStek assumes no liability for any consequence of customer product design, infringement of patents, or application assistance.