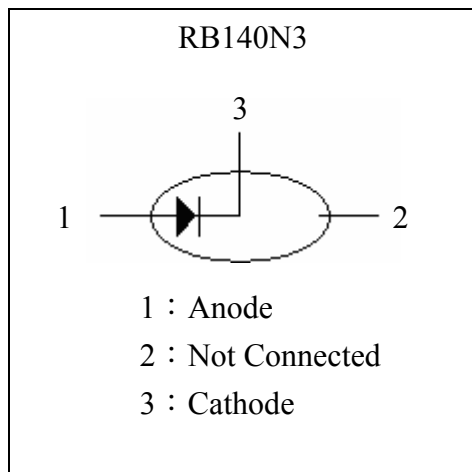
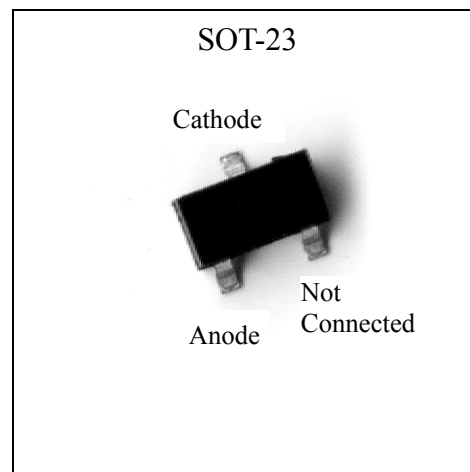

1.2Amp. Surface Mount Schottky Barrier Diodes

RB140N3

Features

- For surface mounted applications.
- For use in low voltage, high frequency inverters, free wheeling, and polarity protection applications
- Plastic material used carries Underwriters Laboratory Flammability Classification 94V-0
- Low leakage current
- High surge capability
- High temperature soldering: 250°C/10 seconds at terminals
- Exceeds environmental standards of MIL-S-19500/228
- Pb-free lead plating package

Equivalent Circuit**Outline****Applications**

- DC-DC converters.
- Strobes.
- Mobile phones.
- Charging circuits.
- Motor control.

**Absolute Maximum Ratings**

(Rating at 25°C ambient temperature unless otherwise specified.)

Parameter	Symbol	Limits	Units
Repetitive peak reverse voltage	V _R RM	40	V
Maximum RMS voltage	V _R RMS	28	V
Maximum DC blocking voltage	V _R	40	V
Average forward rectified current	I _O	1.2	A
Peak forward surge current @8.3ms single half sine wave superimposed on rated load (JEDEC method)	I _{FSM}	10	A
Power Dissipation (Note)	P _D	625	mW
Maximum thermal resistance, Junction to ambient (Note)	R _{th,JA}	250	°C/W
Operating Junction and Storage Temperature range	T _J ; T _{stg}	-50 ~ +150	°C

Note : For a device mounted on 25mm×25mm FR-4 PCB with high coverage of single sided 1oz copper, in still air condition.

Characteristics (T_A=25°C)

Characteristic	Symbol	Condition	Min.	Typ	Max.	Unit
Reverse Breakdown Voltage	V _{(BR)R}	I _R =80μA	40	-	-	V
Forward Voltage	V _F 1	I _F =50mA	-	326	340	mV
	V _F 2	I _F =100mA	-	350	360	
	V _F 3	I _F =250mA	-	393	410	
	V _F 4	I _F =400mA	-	420	460	
	V _F 5	I _F =750mA	-	480	500	
	V _F 6	I _F =1000mA	-	520	550	
	V _F 7	I _F =1500mA	-	-	630	
Reverse Leakage Current	I _R 1	V _R =30V	-	4	20	μA
	I _R 3	V _R =30V, T _A =85°C	-	100	-	μA
Capacitance Between Terminals	C _T	V _R =30V, f=1MHz	-	21	-	pF

Ordering Information

Device	Package	Shipping	Marking
RB140N3	SOT-23 (Pb-free lead plating package)	3000 pcs / Tape & Reel	S14

Typical Characteristics

Fig. 1 Power Derating Curve

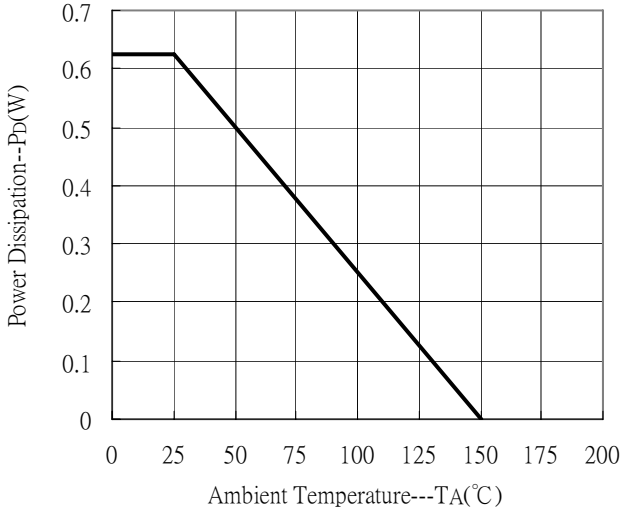

Fig. 2 Maximum Non-repetitive Peak Forward Surge Current

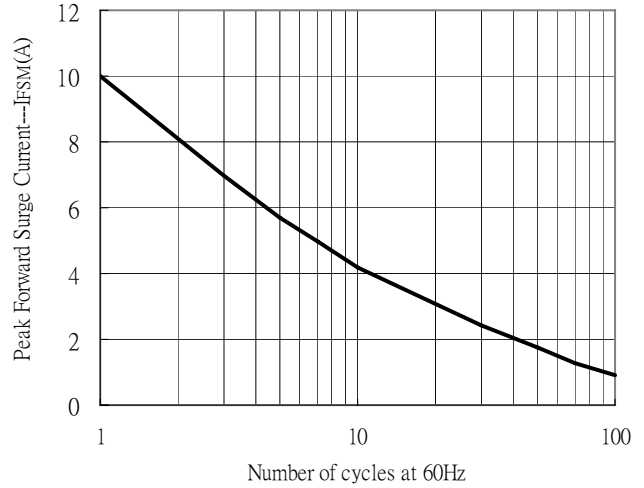

Fig. 3. Forward Characteristics

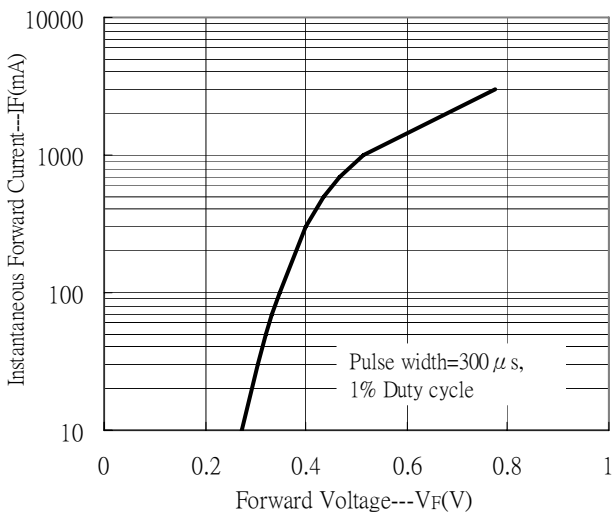

Fig. 4 Typical Reverse Characteristics

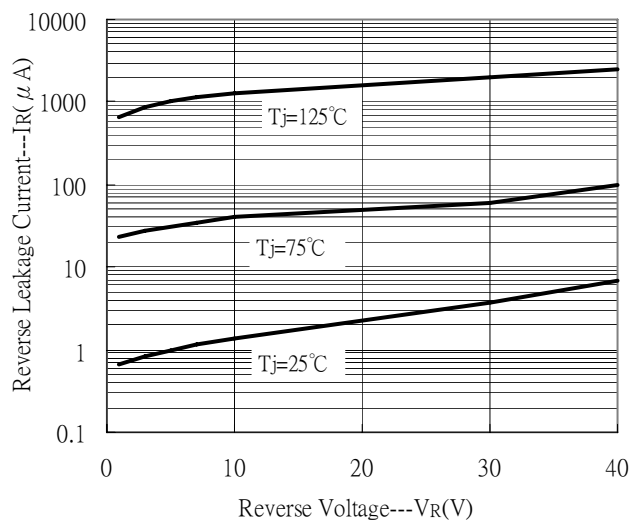
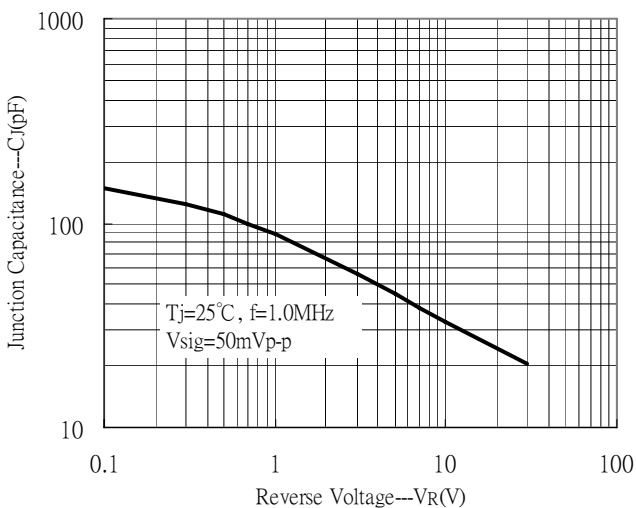
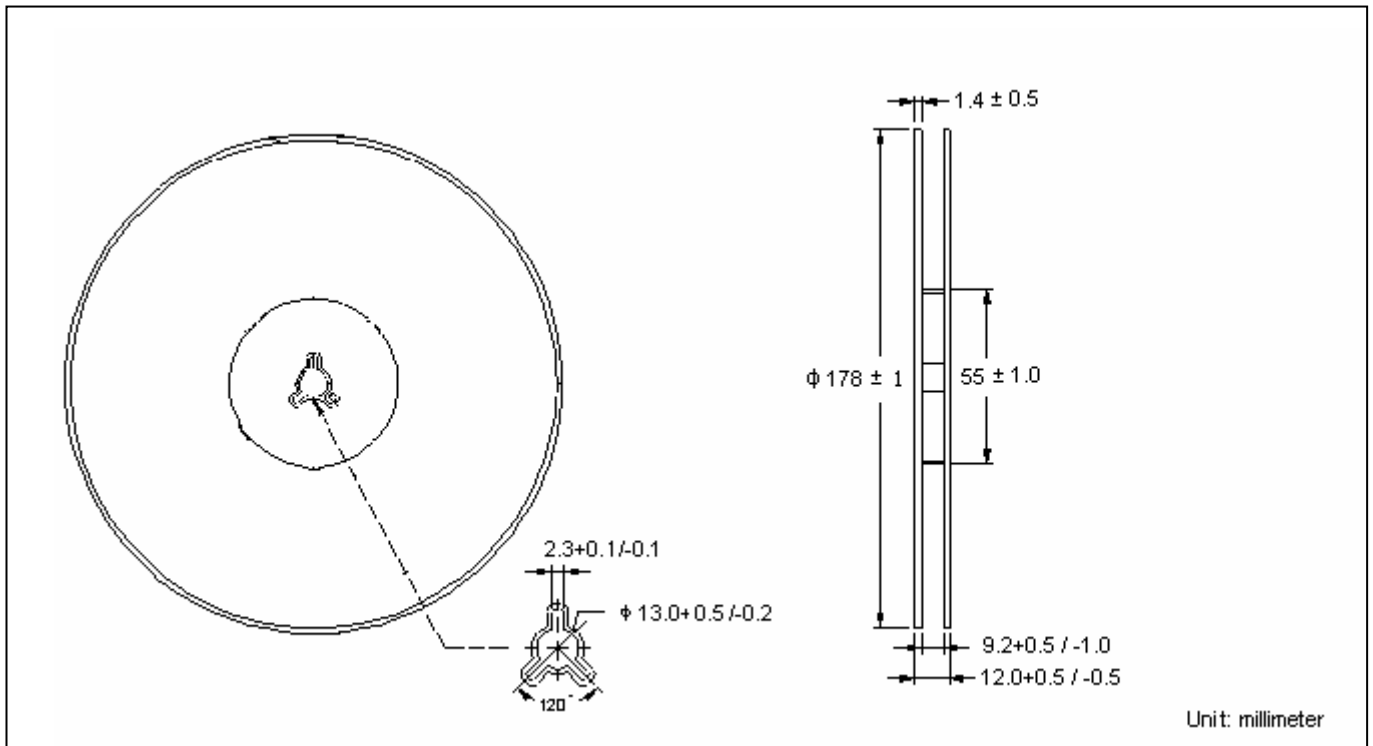

Fig. 5 Typical Junction Capacitance



Reel Dimension



Carrier Tape Dimension

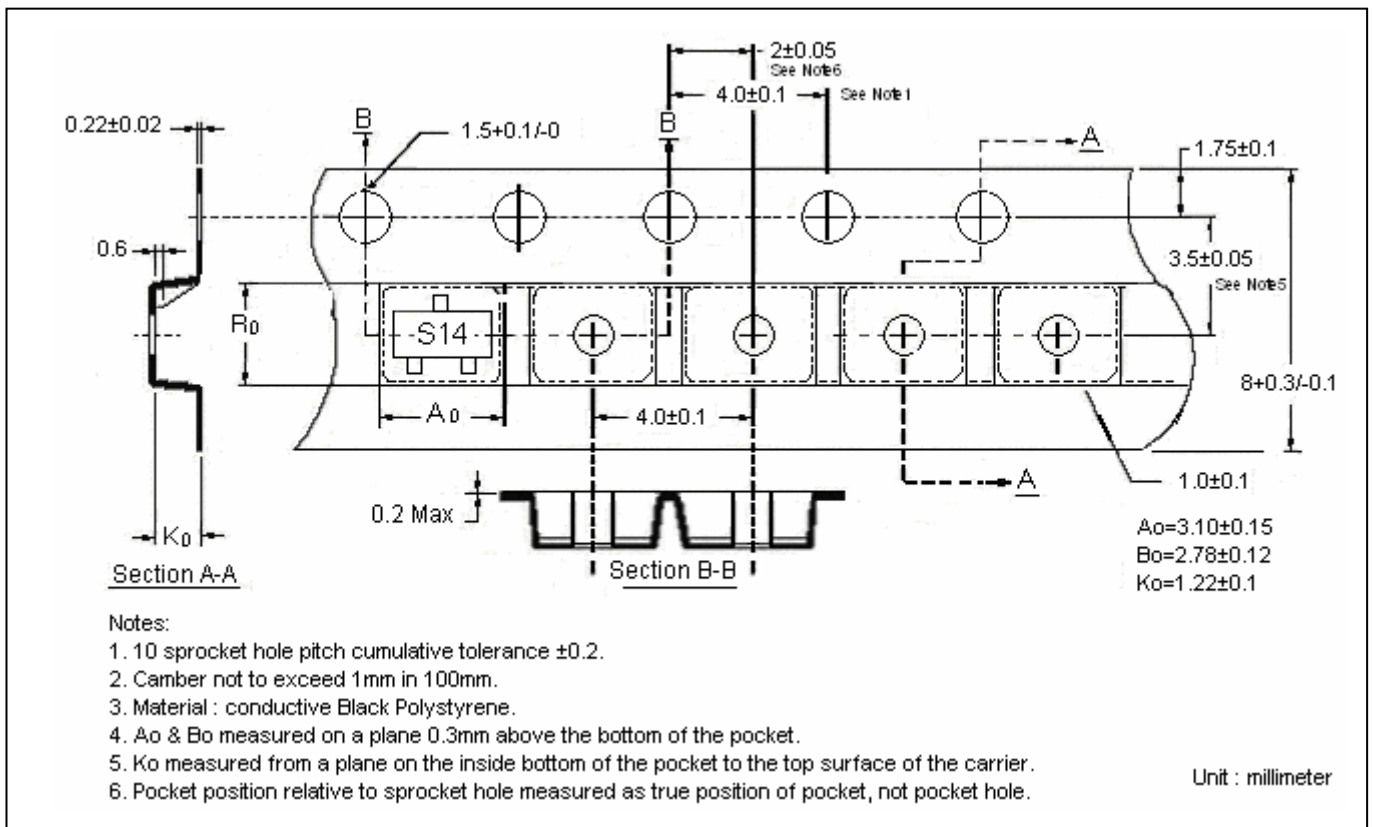

Recommended wave soldering condition

Product	Peak Temperature	Soldering Time
Pb-free devices	260 +0/-5 °C	5 +1/-1 seconds

Recommended temperature profile for IR reflow

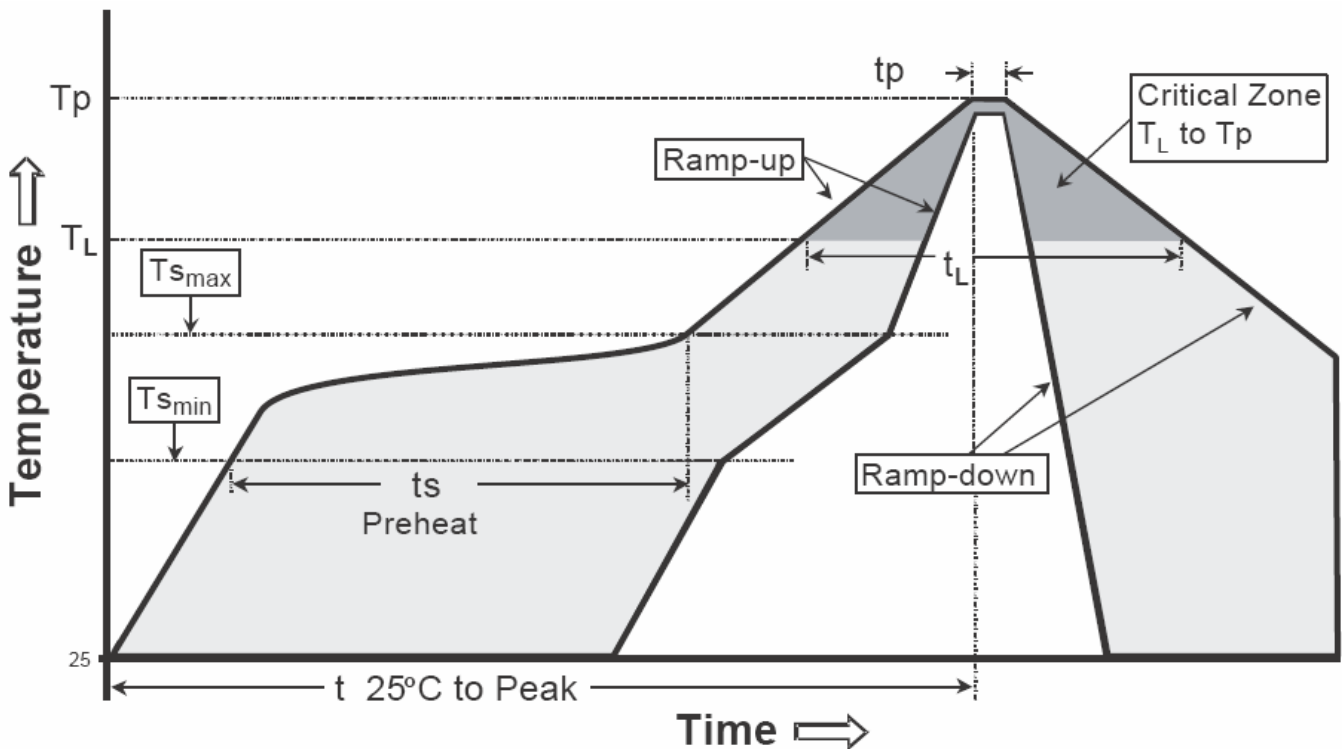

Profile feature	Sn-Pb eutectic Assembly	Pb-free Assembly
Average ramp-up rate (T _{smax} to T _p)	3°C/second max.	3°C/second max.
Preheat		
-Temperature Min(T _{s min})	100°C	150°C
-Temperature Max(T _{s max})	150°C	200°C
-Time(t _{s min} to t _{s max})	60-120 seconds	60-180 seconds
Time maintained above:		
-Temperature (T _L)	183°C	217°C
- Time (t _L)	60-150 seconds	60-150 seconds
Peak Temperature(T _P)	240 +0/-5 °C	260 +0/-5 °C
Time within 5°C of actual peak temperature(tp)	10-30 seconds	20-40 seconds
Ramp down rate	6°C/second max.	6°C/second max.
Time 25 °C to peak temperature	6 minutes max.	8 minutes max.

Note : All temperatures refer to topside of the package, measured on the package body surface.

SOT-23 Dimension

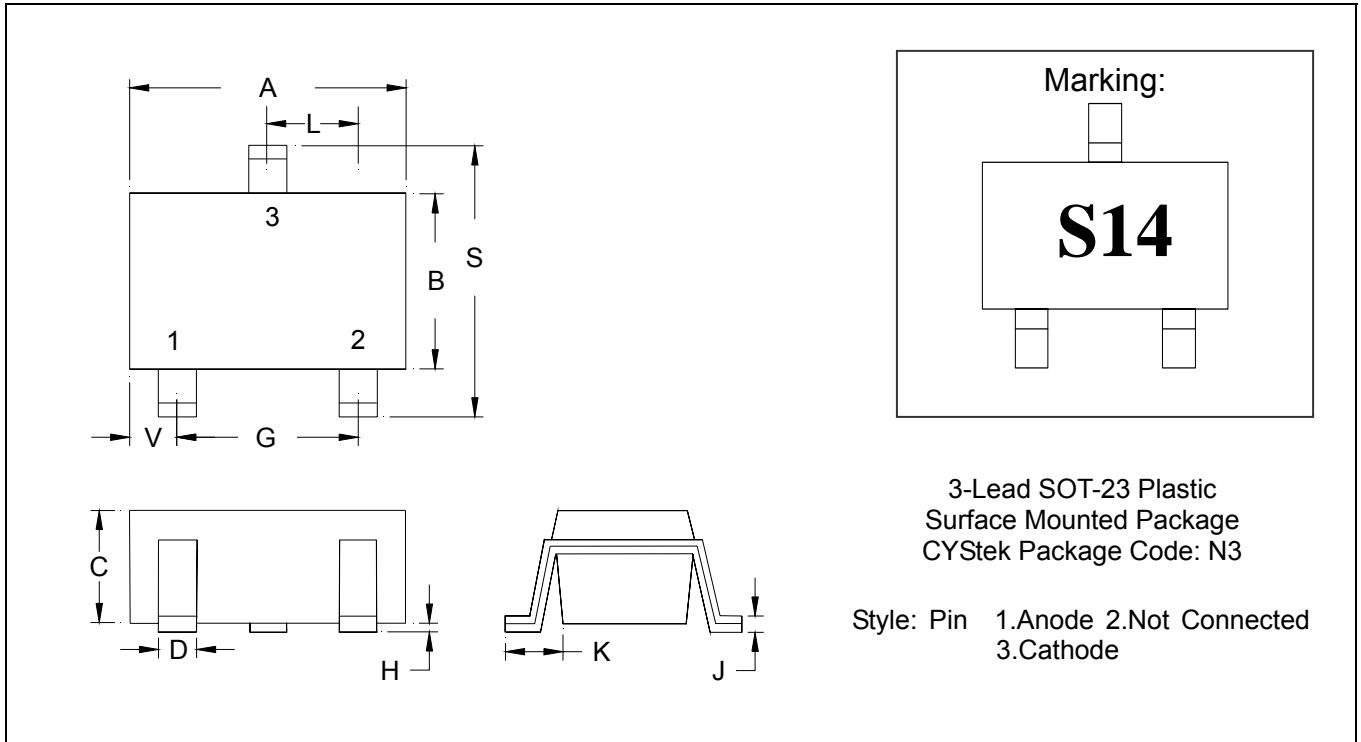

DIM	Inches		Millimeters		DIM	Inches		Millimeters	
	Min.	Max.	Min.	Max.		Min.	Max.	Min.	Max.
A	0.1102	0.1204	2.80	3.04	J	0.0034	0.0070	0.085	0.177
B	0.0472	0.0630	1.20	1.60	K	0.0128	0.0266	0.32	0.67
C	0.0335	0.0512	0.89	1.30	L	0.0335	0.0453	0.85	1.15
D	0.0118	0.0197	0.30	0.50	S	0.0830	0.1083	2.10	2.75
G	0.0669	0.0910	1.70	2.30	V	0.0098	0.0256	0.25	0.65
H	0.0005	0.0040	0.013	0.10					

Notes: 1.Controlling dimension: millimeters.
 2.Maximum lead thickness includes lead finish thickness, and minimum lead thickness is the minimum thickness of base material.
 3.If there is any question with packing specification or packing method, please contact your local CYStek sales office.

Material:

- Lead: Pure tin plated.
- Mold Compound: Epoxy resin family, flammability solid burning class: UL94V-0

Important Notice:

- All rights are reserved. Reproduction in whole or in part is prohibited without the prior written approval of CYStek.
- CYStek reserves the right to make changes to its products without notice.
- CYStek **semiconductor products are not warranted to be suitable for use in Life-Support Applications, or systems.**
- CYStek assumes no liability for any consequence of customer product design, infringement of patents, or application assistance.