



10Amp. Schottky Barrier Rectifiers

MBR10200J3

$I_{F(AV)}$	2 × 5A
V_{RRM}	200V
T_j	175°C
$V_{F(TYP.)}$	0.7V

Features

- 175°C operating junction temperature
- Low V_F and low I_R type
- Metal silicon junction, major carrier conduction
- 10A total (5A per diode leg)
- Guardring for over voltage protection
- Low power loss, high efficiency
- High surge capability
- For use in low voltage, high frequency inverters, free wheeling, and polarity protection application
- Pb-free lead plating and halogen-free package

Mechanical Data

- Case: TO-252 molded plastic
- Mounting Position: Any
- Weight: 0.34 grams approximately
- Terminals: Pure tin plated, lead-free, solderable per MIL-STD-750 method 2026
- Epoxy: UL 94V-0 rate flame retardant
- Polarity : Indicated by diode symbol

Ordering Information

Device	Package	Shipping
MBR10200J3-0-T3-G	TO-252 (Pb-free lead plating and halogen-free package)	2500 pcs / Tape & Reel

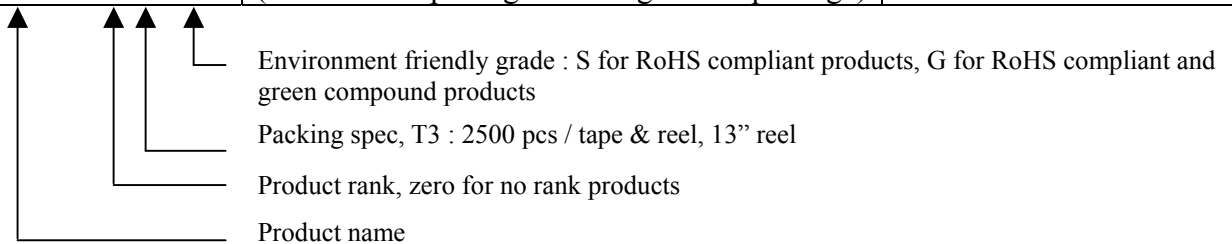

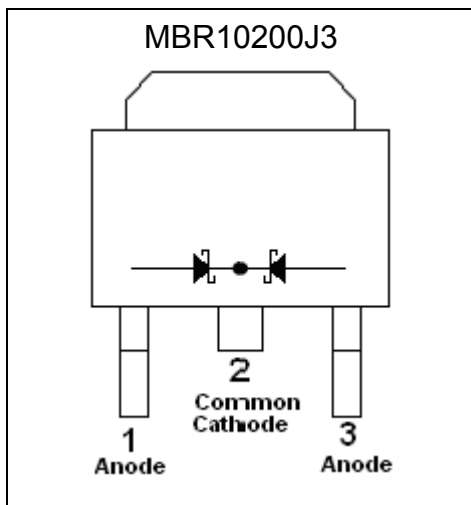
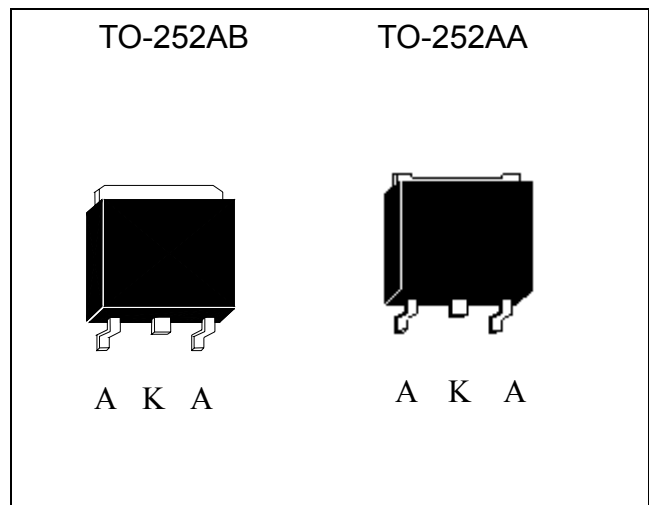
Equivalent Circuit

Outline

Maximum Ratings and Electrical Characteristics (Per Diode Leg)

(Rating at 25°C ambient temperature unless otherwise specified. Single phase, half wave, 60Hz, resistive or inductive load. For capacitive load, derate current by 20%.)

Parameter	Symbol	Min.	Typ.	Max.	Units	
Maximum Recurrent peak reverse voltage	V_{RRM}			200	V	
Maximum RMS voltage	V_{RMS}			140	V	
Maximum DC blocking voltage	V_{DC}			200	V	
Maximum instantaneous forward voltage at (Note 1)	V_F		0.7	0.90	V	
				$I_F=5A, T_C=125^\circ C$		0.74
				$I_F=10A, T_C=25^\circ C$		1.00
				$I_F=10A, T_C=125^\circ C$		0.87
Maximum Average forward rectified current @ $T_C=133^\circ C$	$I_{F(AV)}$			5	A	
				Per Diode		10
Peak repetitive forward current (square wave, 20kHz, $T_C=133^\circ C$)	I_{FRM}			10	A	
Non-repetitive peak forward surge current @ 8.3ms single half sine wave superimposed on rated load (JEDEC method)	I_{FSM}			110	A	
Peak repetitive reverse surge current (Note 1), $T_J < 175^\circ C$	I_{RRM}			2	A	
Maximum instantaneous reverse current at	I_R			5	μA	
				$V_R=200V, T_C=125^\circ C$	5	mA
Voltage rate of change, (rated V_R)	dV/dt			10,000	V/ μs	
Typical junction capacitance @ $f=1MHz$ and applied 5V reverse voltage	C_J		65		pF	
ESD susceptibility (Note 2)				8000	V	
Storage temperature range	T_{stg}	-65		+175	$^\circ C$	
Operating junction temperature range	T_J	-65		+175	$^\circ C$	

Notes : 1. 2.0 μs pulse width, $f=1.0kHz$

2. Human body model, 1.5k Ω in series with 100pF

Thermal Data

Parameter		Symbol	Value	Unit
Maximum Thermal Resistance, Junction-to-case	Per diode	R _{th,j-c}	2.4	°C/W
	Total		4	
Maximum Thermal Resistance, Junction-to-ambient		R _{th,j-a}	90	°C/W

Recommended soldering footprint

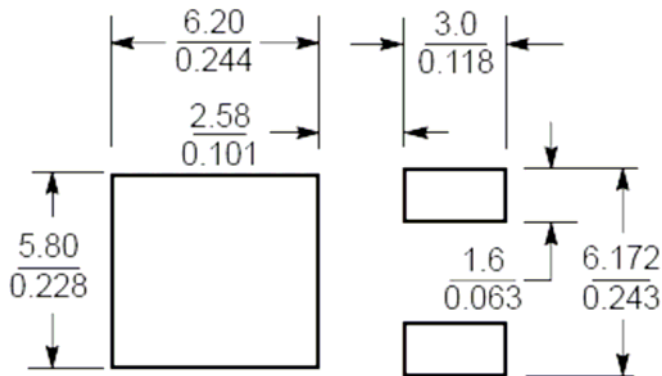

Unit ($\frac{\text{mm}}{\text{inch}}$)



Characteristic Curves

Forward Current Derating Curve

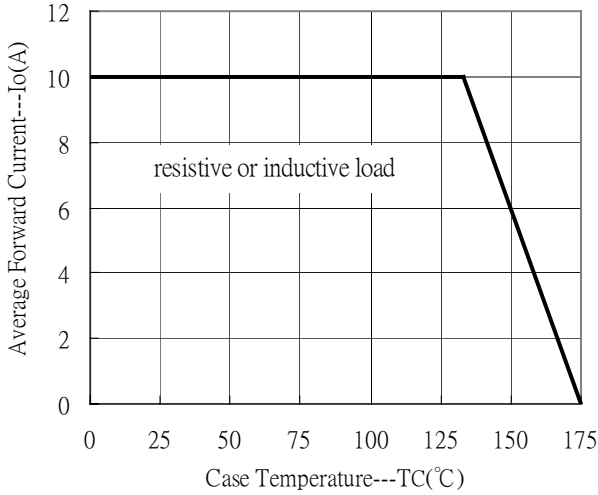

Maximum Non-Repetitive Forward Surge Current

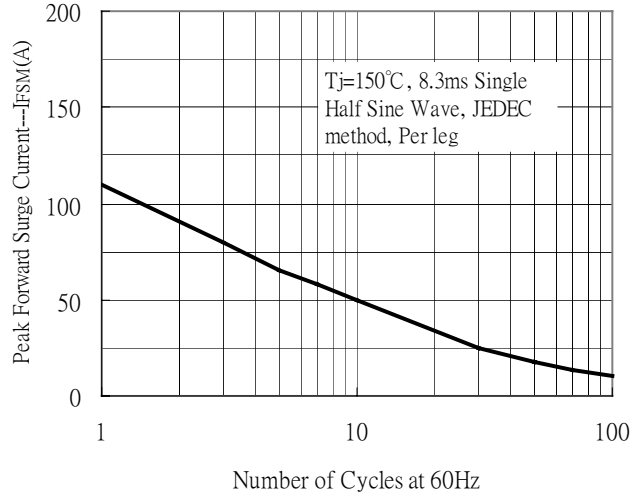

Forward Current vs Forward Voltage

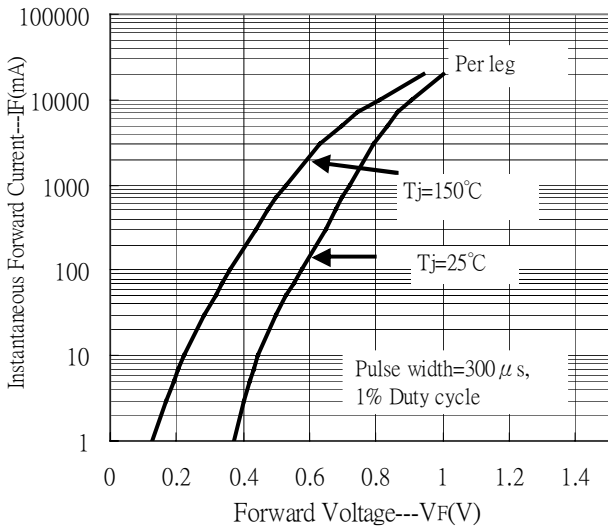

Junction Capacitance vs Reverse Voltage

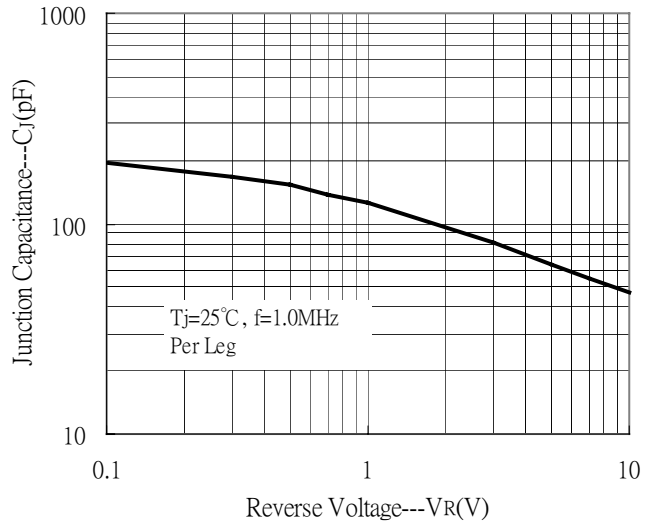

Reverse Leakage Current vs Reverse Voltage

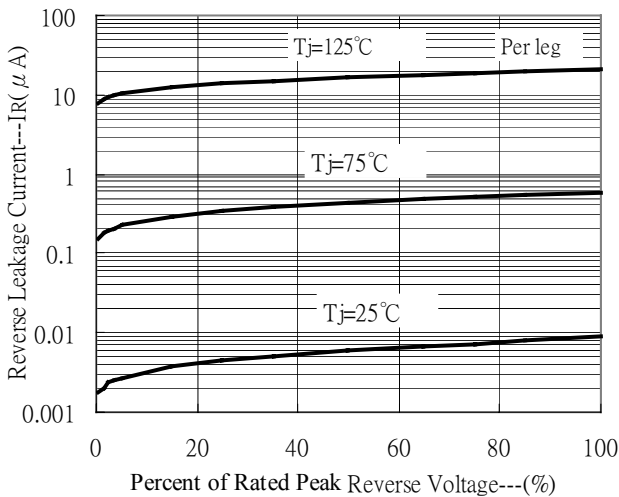

Reel Dimension

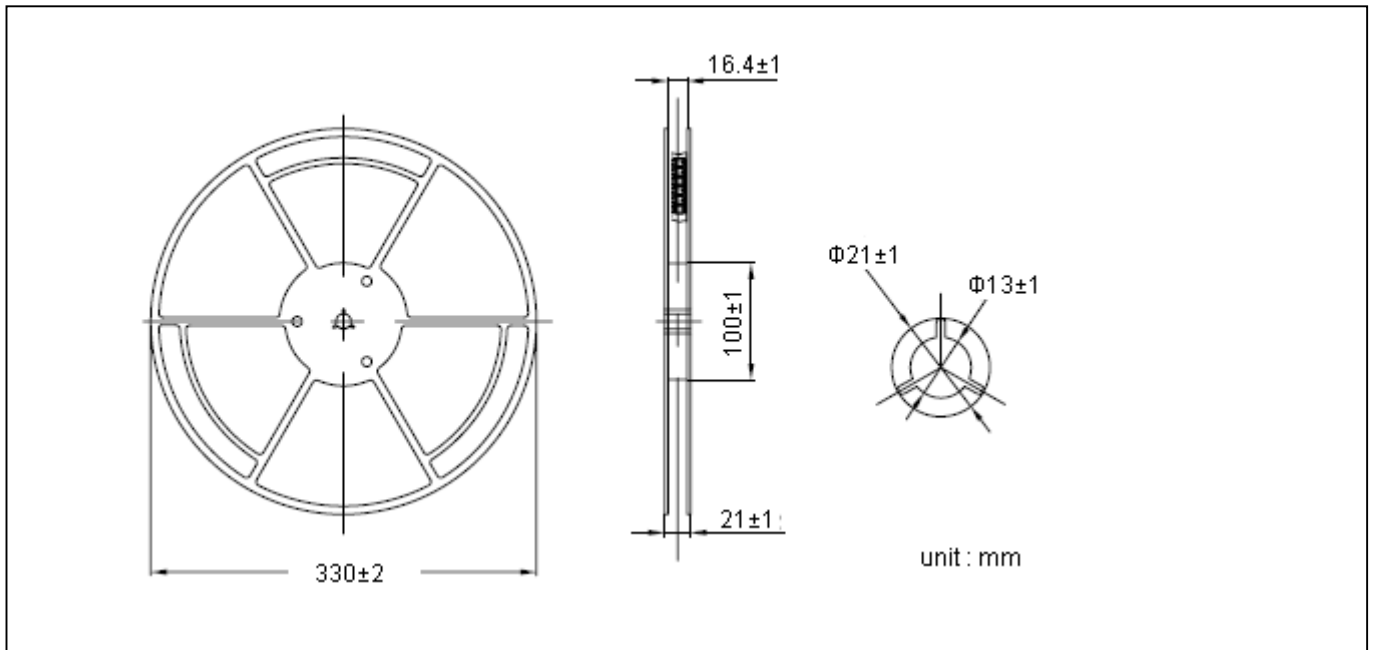

Carrier Tape Dimension

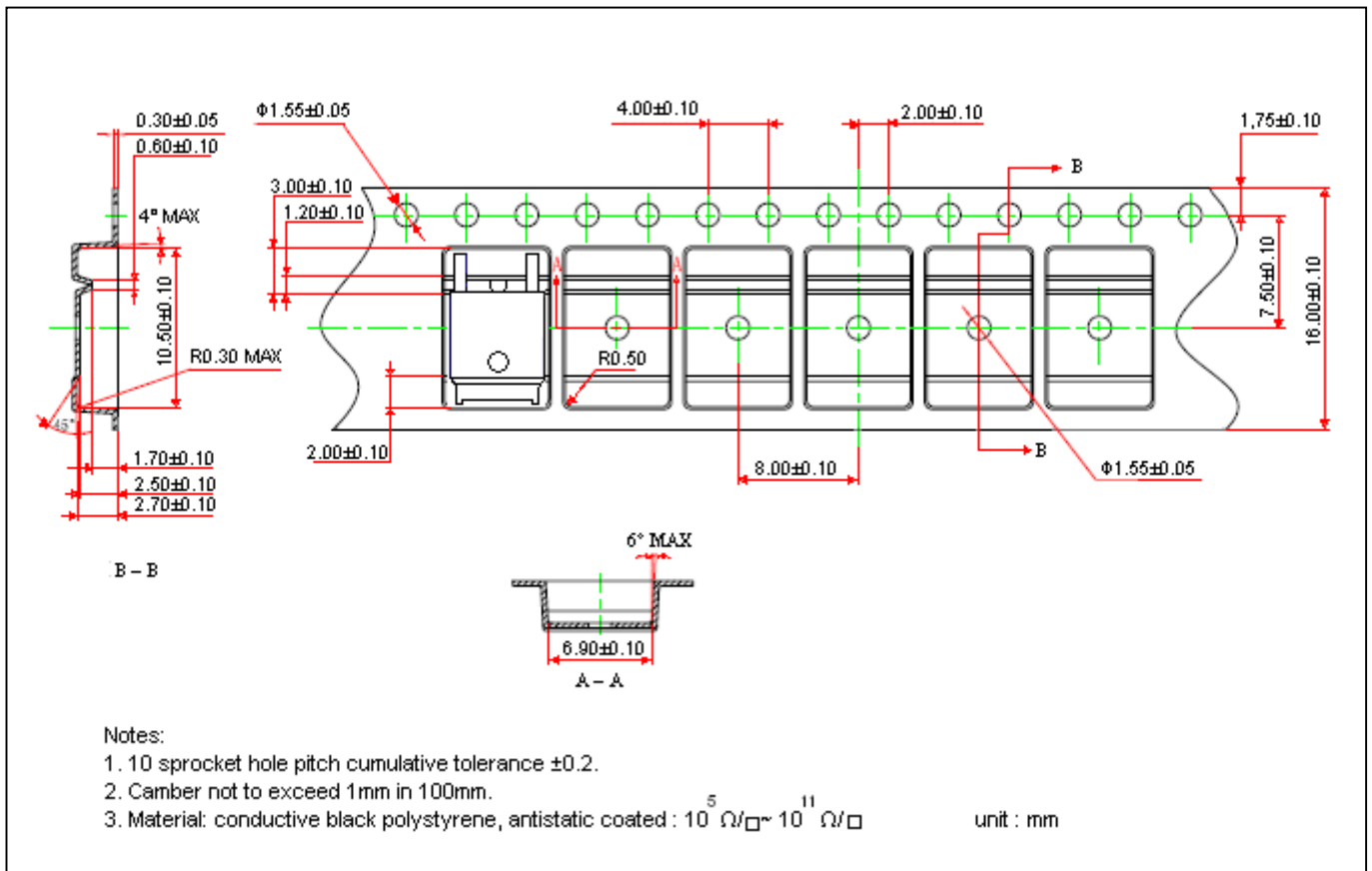

Recommended wave soldering condition

Product	Peak Temperature	Soldering Time
Pb-free devices	260 +0/-5 °C	5 +1/-1 seconds

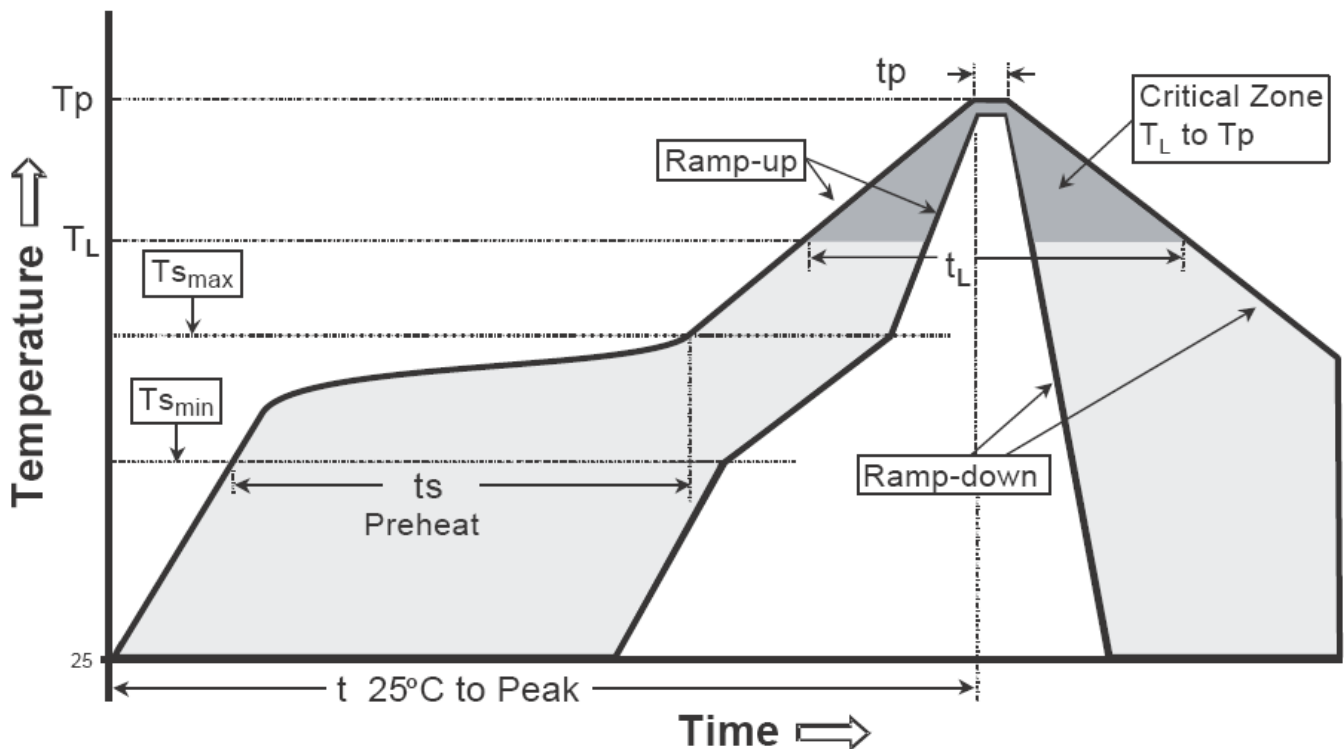
Recommended temperature profile for IR reflow

Profile feature	Sn-Pb eutectic Assembly	Pb-free Assembly
Average ramp-up rate (T _{smax} to T _p)	3°C/second max.	3°C/second max.
Preheat		
-Temperature Min(T _{s min})	100°C	150°C
-Temperature Max(T _{s max})	150°C	200°C
-Time(t _{s min} to t _{s max})	60-120 seconds	60-180 seconds
Time maintained above:		
-Temperature (T _L)	183°C	217°C
- Time (t _L)	60-150 seconds	60-150 seconds
Peak Temperature(T _P)	240 +0/-5 °C	260 +0/-5 °C
Time within 5°C of actual peak temperature(tp)	10-30 seconds	20-40 seconds
Ramp down rate	6°C/second max.	6°C/second max.
Time 25 °C to peak temperature	6 minutes max.	8 minutes max.

TO-252AB Dimension

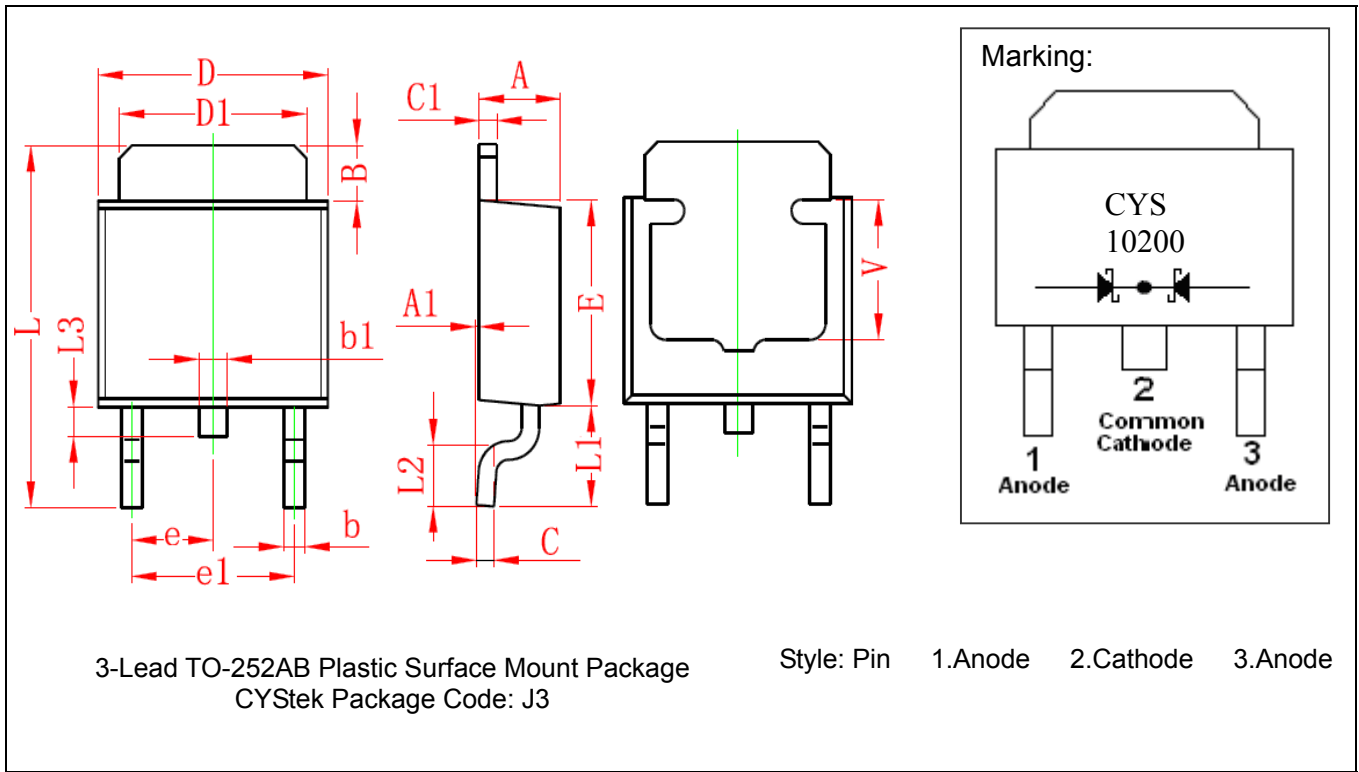

*: Typical

DIM	Inches		Millimeters		DIM	Inches		Millimeters	
	Min.	Max.	Min.	Max.		Min.	Max.	Min.	Max.
A	0.087	0.094	2.200	2.400	E	0.213	0.224	5.400	5.700
A1	0.000	0.005	0.000	0.127	e	*0.091		*2.300	
B	0.053	0.065	1.350	1.650	e1	0.177	0.185	4.500	4.700
b	0.020	0.028	0.500	0.700	L	0.374	0.390	9.500	9.900
b1	0.028	0.035	0.700	0.900	L1	0.100	0.114	2.550	2.900
c	0.017	0.023	0.430	0.580	L2	0.055	0.070	1.400	1.780
c1	0.017	0.023	0.430	0.580	L3	0.014	0.026	0.350	0.650
D	0.250	0.262	6.350	6.650	V	0.150	REF	3.800	REF
D1	0.205	0.213	5.200	5.400					

Notes: 1.Controlling dimension: millimeters.
 2.Maximum lead thickness includes lead finish thickness, and minimum lead thickness is the minimum thickness of base material.
 3.If there is any question with packing specification or packing method, please contact your local CYStek sales office.

Material:

- Lead : Pure tin plated
- Mold Compound: Epoxy resin family, flammability solid burning class: UL94V-0

TO-252AA Dimension

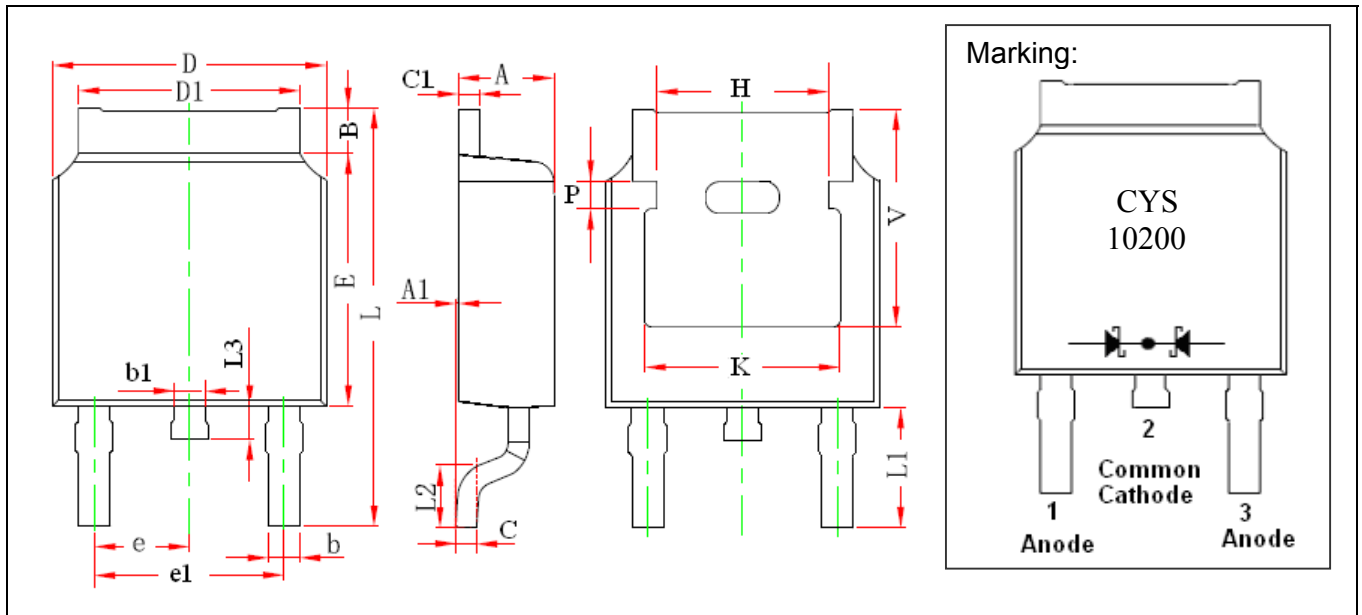

3-Lead TO-252AA Plastic Surface Mount Package
 CYStek Package Code: J3

Style: Pin 1.Anode 2.Cathode 3.Anode

*: Typical

DIM	Inches		Millimeters		DIM	Inches		Millimeters	
	Min.	Max.	Min.	Max.		Min.	Max.	Min.	Max.
A	0.087	0.094	2.200	2.400	e	0.086	0.094	2.186	2.386
A1	0.000	0.005	0.000	0.127	e1	0.172	0.188	4.372	4.772
B	0.039	0.048	0.990	1.210	H	0.163	REF	4.140	REF
b	0.026	0.034	0.660	0.860	K	0.190	REF	4.830	REF
b1	0.026	0.034	0.660	0.860	L	0.386	0.409	9.800	10.400
C	0.018	0.023	0.460	0.580	L1	0.114	REF	2.900	REF
C1	0.018	0.023	0.460	0.580	L2	0.055	0.067	1.400	1.700
D	0.256	0.264	6.500	6.700	L3	0.024	0.039	0.600	1.000
D1	0.201	0.215	5.100	5.460	P	0.030	REF	0.750	REF
E	0.236	0.244	6.000	6.200	V	0.211	REF	5.350	REF

Notes: 1.Controlling dimension: millimeters.
 2.Maximum lead thickness includes lead finish thickness, and minimum lead thickness is the minimum thickness of base material.
 3.If there is any question with packing specification or packing method, please contact your local CYStek sales office.

Material:

- Lead : Pure tin plated
- Mold Compound: Epoxy resin family, flammability solid burning class: UL94V-0

Important Notice:

- All rights are reserved. Reproduction in whole or in part is prohibited without the prior written approval of CYStek.
- CYStek reserves the right to make changes to its products without notice.
- CYStek **semiconductor products are not warranted to be suitable for use in Life-Support Applications, or systems.**
- CYStek assumes no liability for any consequence of customer product design, infringement of patents, or application assistance.