

High voltage switching (double) diodes

BAS21/A/C/SN3

Description

High voltage switching diodes encapsulated in a SOT-23 small plastic SMD package. Single diodes and double diodes with different pinning are available.

Features

- Fast switching speed
- Low forward voltage drop
- Pb-free lead plating and halogen-free package

Mechanical Data

- Case : SOT-23, molded plastic
- Terminals : Solderable per MIL-STD-202 Method 208
- Weight : 0.008 grams(approx.)

Pinning

Pin	Description			
	BAS21	BAS21A	BAS21C	BAS21S
1	A	K1	A1	A1
2	NC	K2	A2	K2
3	K	A1,A2	K1,K2	K1,A1

Outline

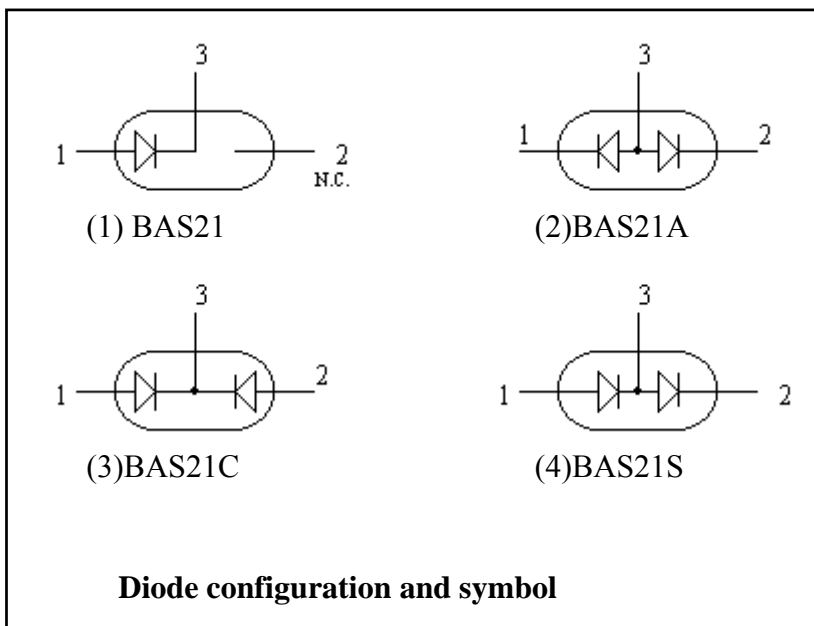
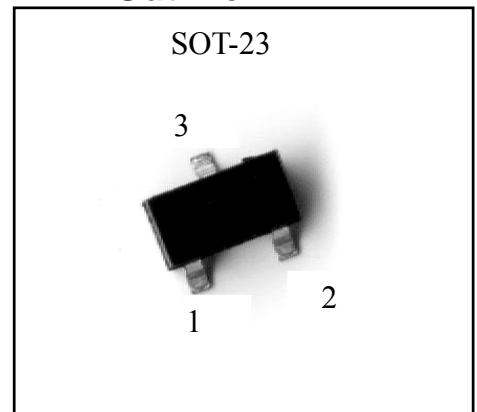

Marking:

Type	Marking Code
BAS21N3	JS
BAS21AN3	JS2
BAS21CN3	JS3
BAS21SN3	JS4



Absolute Maximum Ratings($T_a=25^{\circ}\text{C}$, unless otherwise specified)

Parameter	Symbol	Limits	unit
Repetitive Peak Reverse Voltage	V_{RRM}	250	V
Working Peak Reverse Voltage	V_{RWM}		
DC Blocking Voltage	V_R		
Forward Continuous Current	I_{FM}	400	mA
Average Rectified Output Current	I_O	200	mA
Non-repetitive Peak Forward Surge Current	I_{FSM}	@ $t_p=1\mu\text{s}$ 9	A
		@ $t_p=100\mu\text{s}$ 3	
		@ $t_p=1\text{s}$ 1.7	
Repetitive Peak Forward Surge Current	I_{FRM}	625	mA
Power Dissipation	P_D	250	mW
Thermal Resistance, Junction to Ambient	$R_{\theta JA}$	500	$^{\circ}\text{C}/\text{W}$
Operating Junction Temperature Range	T_J	-65~+150	$^{\circ}\text{C}$
Storage Temperature Range	T_{STG}	-65~+150	$^{\circ}\text{C}$

Characteristics ($T_a=25^{\circ}\text{C}$)

Characteristic	Symbol	Condition	Min.	Max.	Unit
Reverse Breakdown Voltage	V_{BR}	$I_R=100\mu\text{A}$	250	-	V
Forward Voltage (Note)	V_F	$I_F=100\text{mA}$	-	1	V
		$I_F=200\text{mA}$	-	1.25	V
Reverse Leakage Current	I_R	$V_R=200\text{V}$	-	100	nA
		$V_R=200\text{V}, T_j=150^{\circ}\text{C}$	-	100	μA
Diode Capacitance	C_D	$V_R=0\text{V}, f=1\text{MHz}$	-	5	pF
Reverse Recovery Time	t_{rr}	$I_F=I_R=30\text{mA}, R_L=100\Omega$ measured at $I_R=3\text{mA}$	-	50	ns

Note: Pulse test, $t_p=300\mu\text{s}$, duty cycle<2%.

Ordering Information

Device	Package	Shipping	Marking
BAS21N3-0-T1-G	SOT-23 (Pb-free lead plating and halogen-free package)	3000 pcs / Tape & Reel	JS
BAS21AN3-0-T1-G			JS2
BAS21CN3-0-T1-G			JS3
BAS21SN3-0-T1-G			JS4

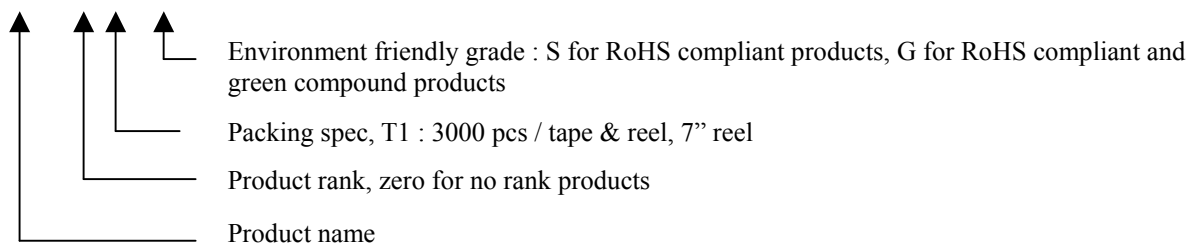

Typical Characteristics

Forward Current vs Forward Voltage

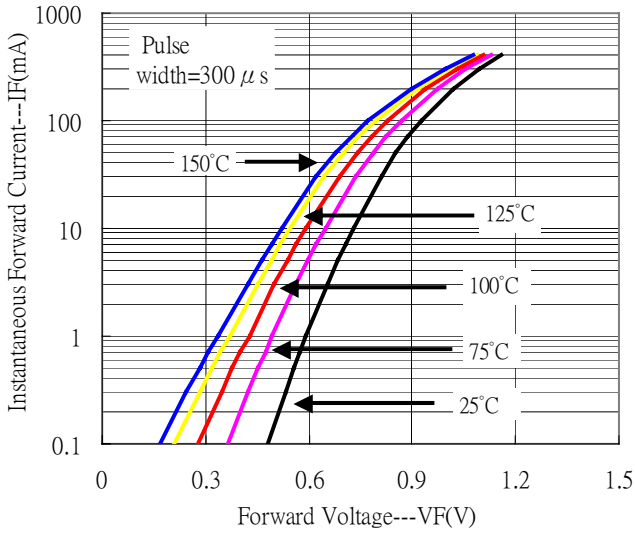

Reverse Leakage Current vs Reverse Voltage

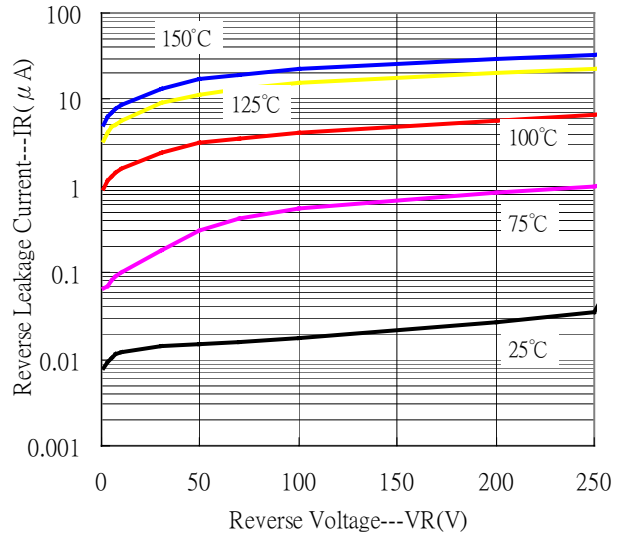

Junction Capacitance vs Reverse Voltage

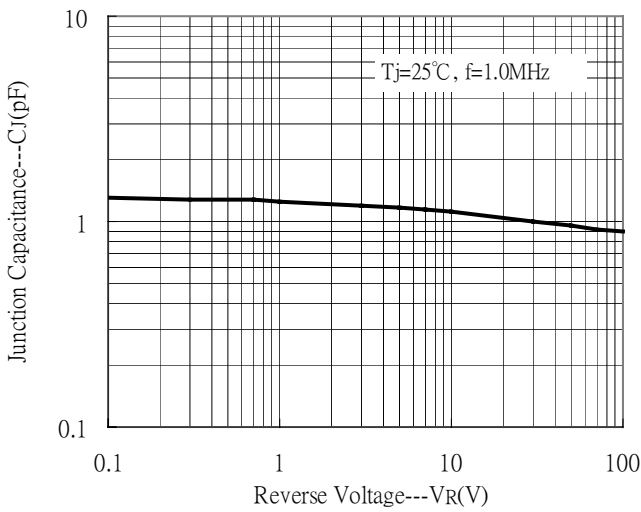

Power Derating Curve

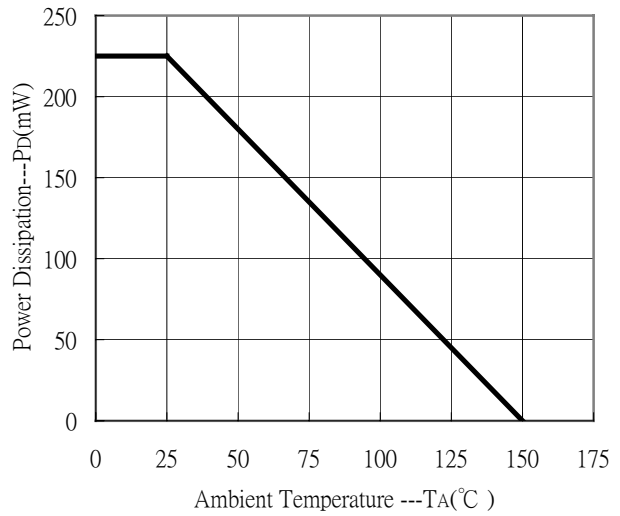

Typical Characteristics(Cont.)

Maximum Permissible Non-repetitive Peak Forward Surge Current

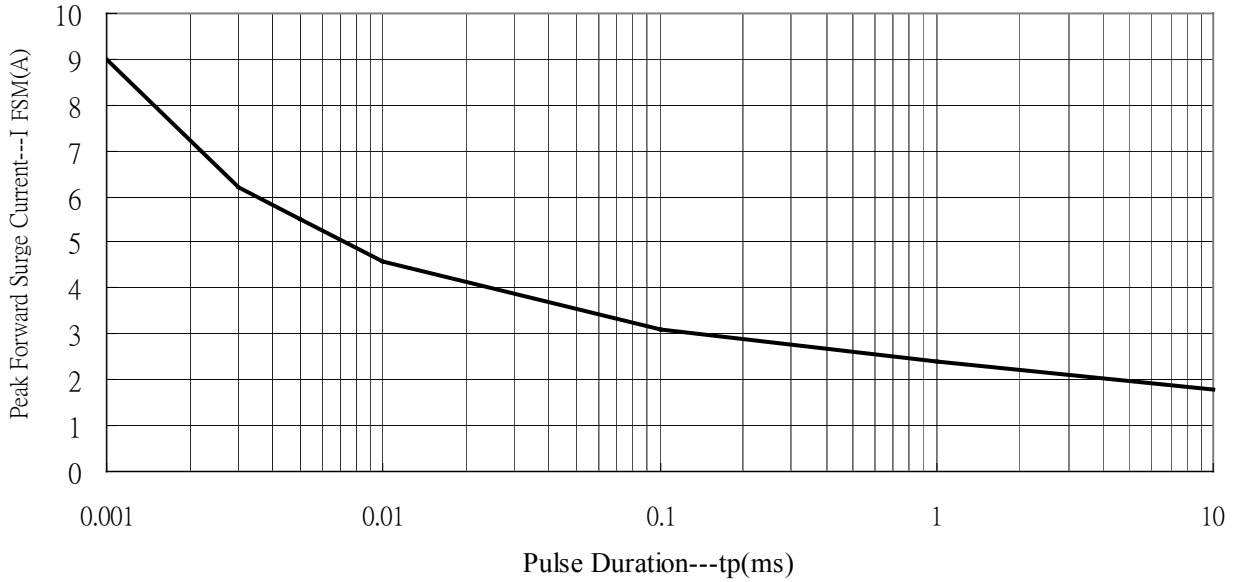

Recommended Soldering Footprint

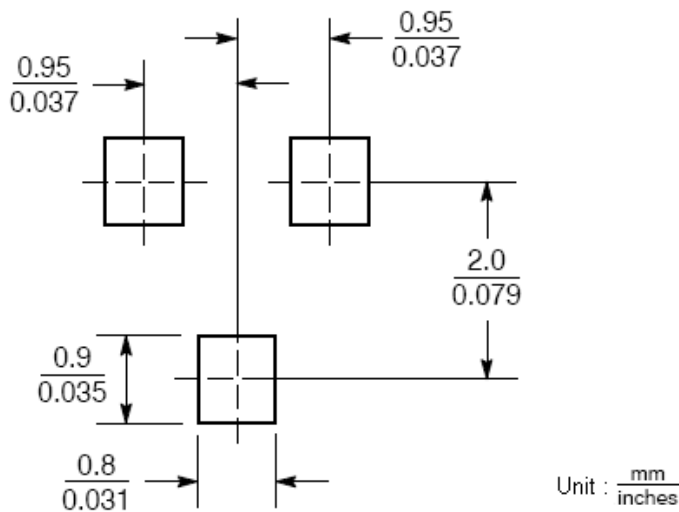

Reel Dimension

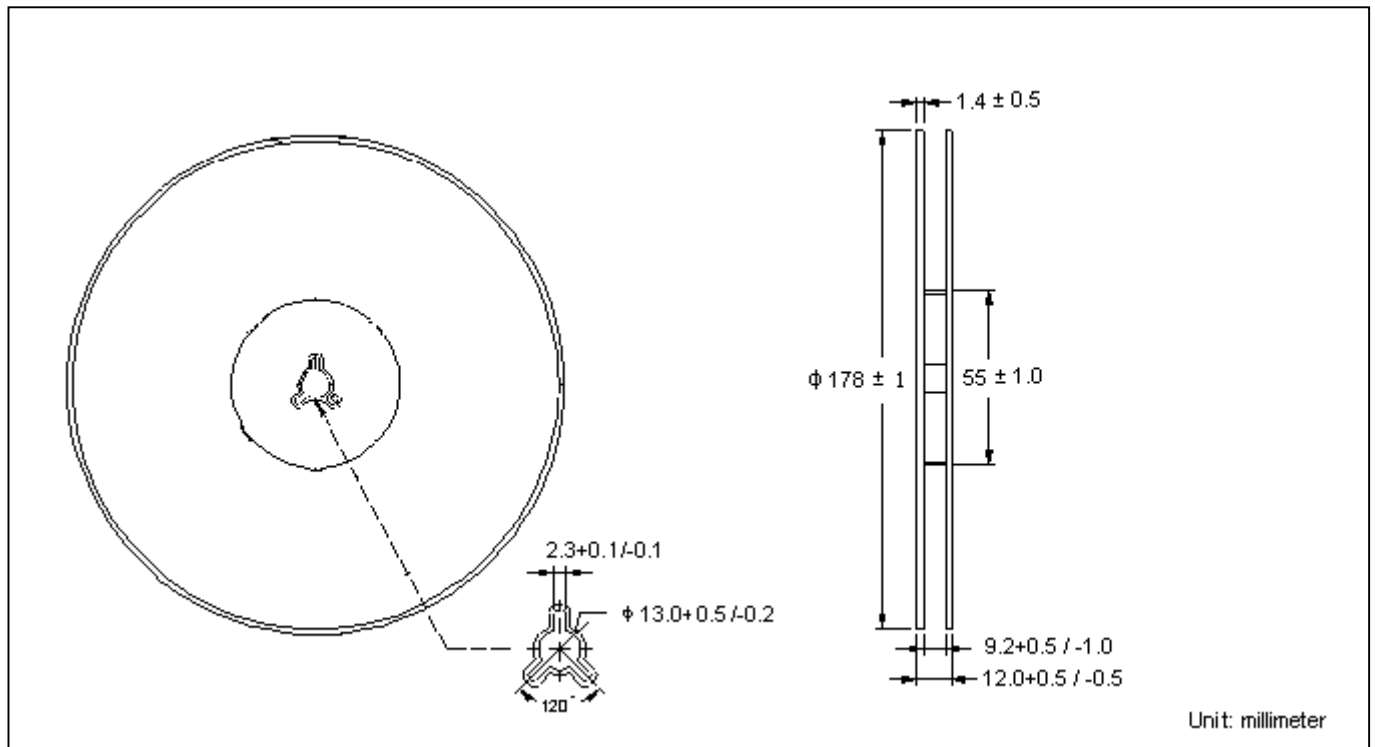

Carrier Tape Dimension

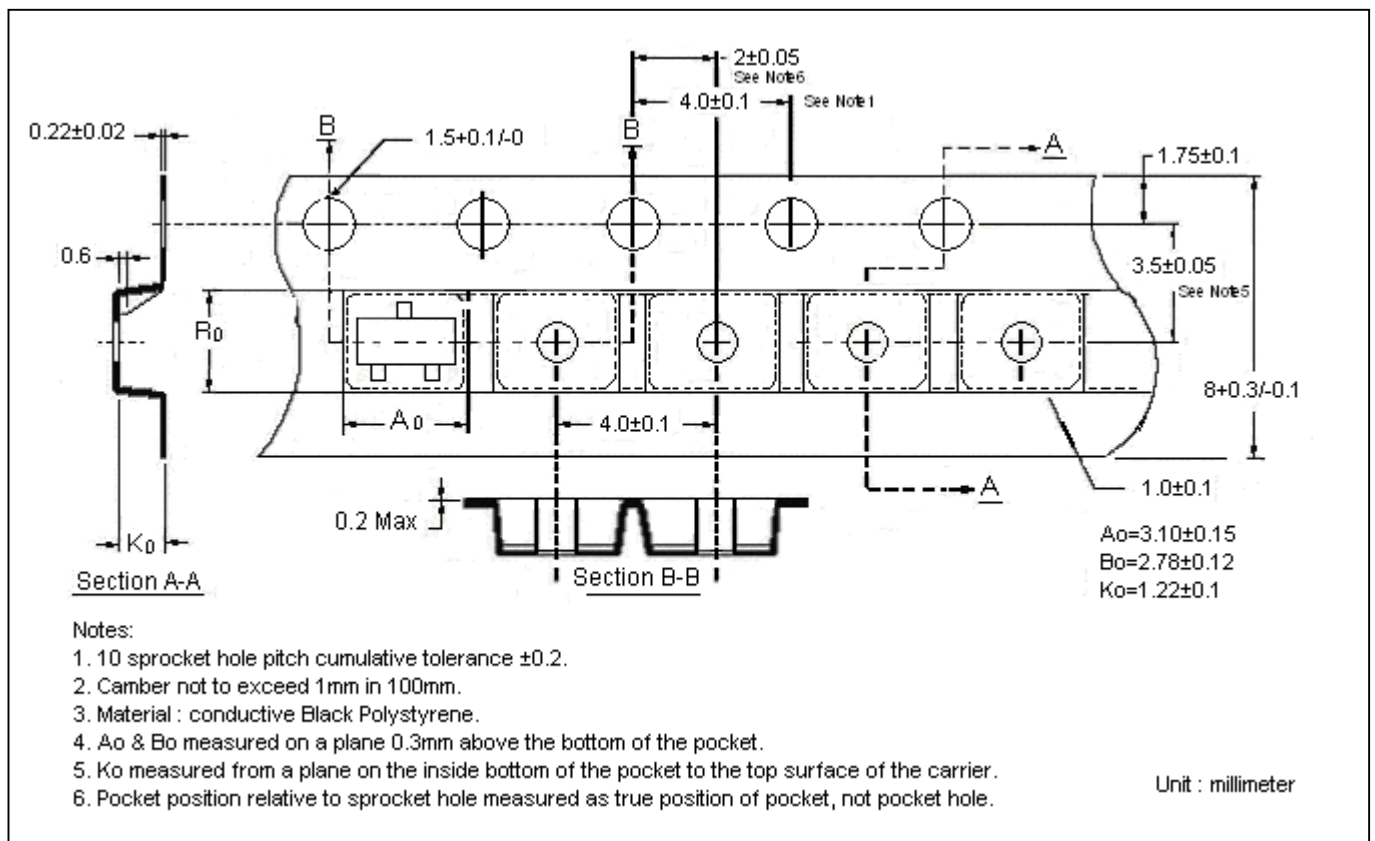

Recommended wave soldering condition

Product	Peak Temperature	Soldering Time
Pb-free devices	260 +0/-5 °C	5 +1/-1 seconds

Recommended temperature profile for IR reflow

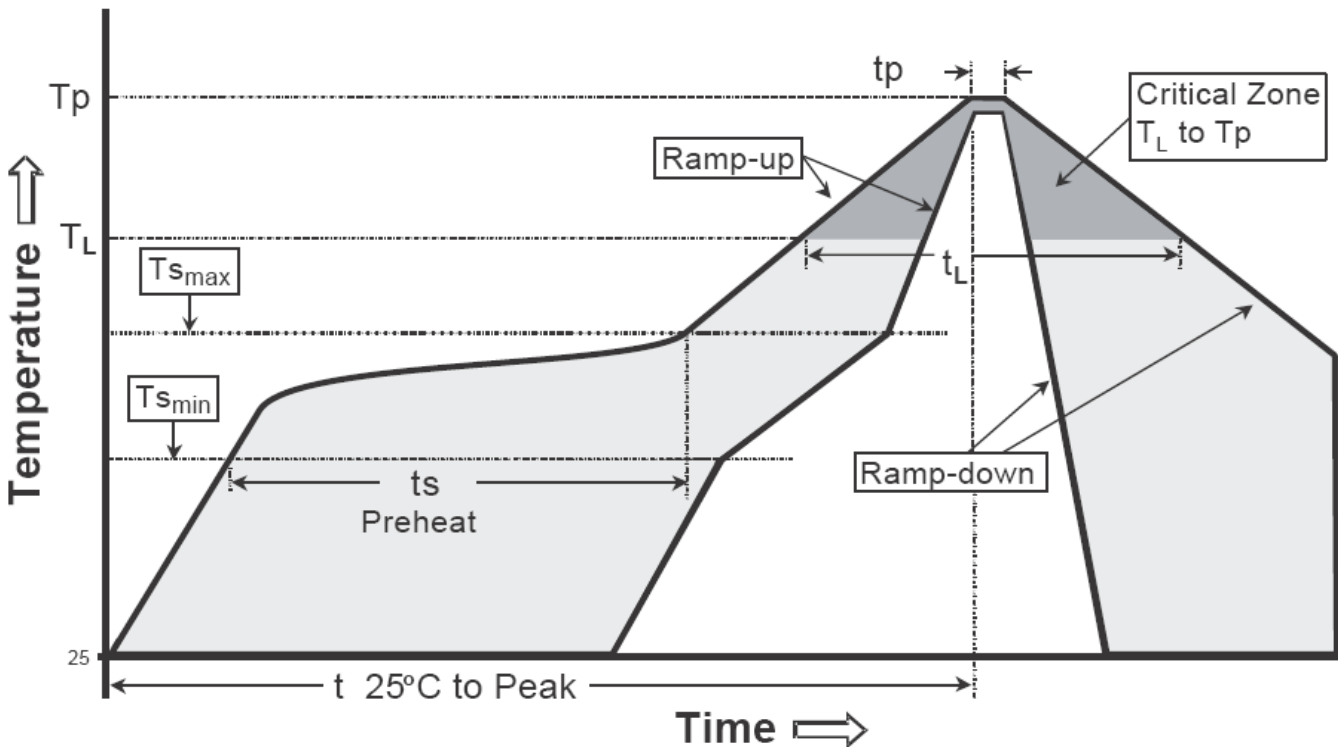

Profile feature	Sn-Pb eutectic Assembly	Pb-free Assembly
Average ramp-up rate (Tsmax to Tp)	3°C/second max.	3°C/second max.
Preheat		
-Temperature Min(Ts min)	100°C	150°C
-Temperature Max(Ts max)	150°C	200°C
-Time(ts min to ts max)	60-120 seconds	60-180 seconds
Time maintained above:		
-Temperature (TL)	183°C	217°C
- Time (tL)	60-150 seconds	60-150 seconds
Peak Temperature(TP)	240 +0/-5 °C	260 +0/-5 °C
Time within 5°C of actual peak temperature(tp)	10-30 seconds	20-40 seconds
Ramp down rate	6°C/second max.	6°C/second max.
Time 25 °C to peak temperature	6 minutes max.	8 minutes max.

Note : All temperatures refer to topside of the package, measured on the package body surface.

SOT-23 Dimension

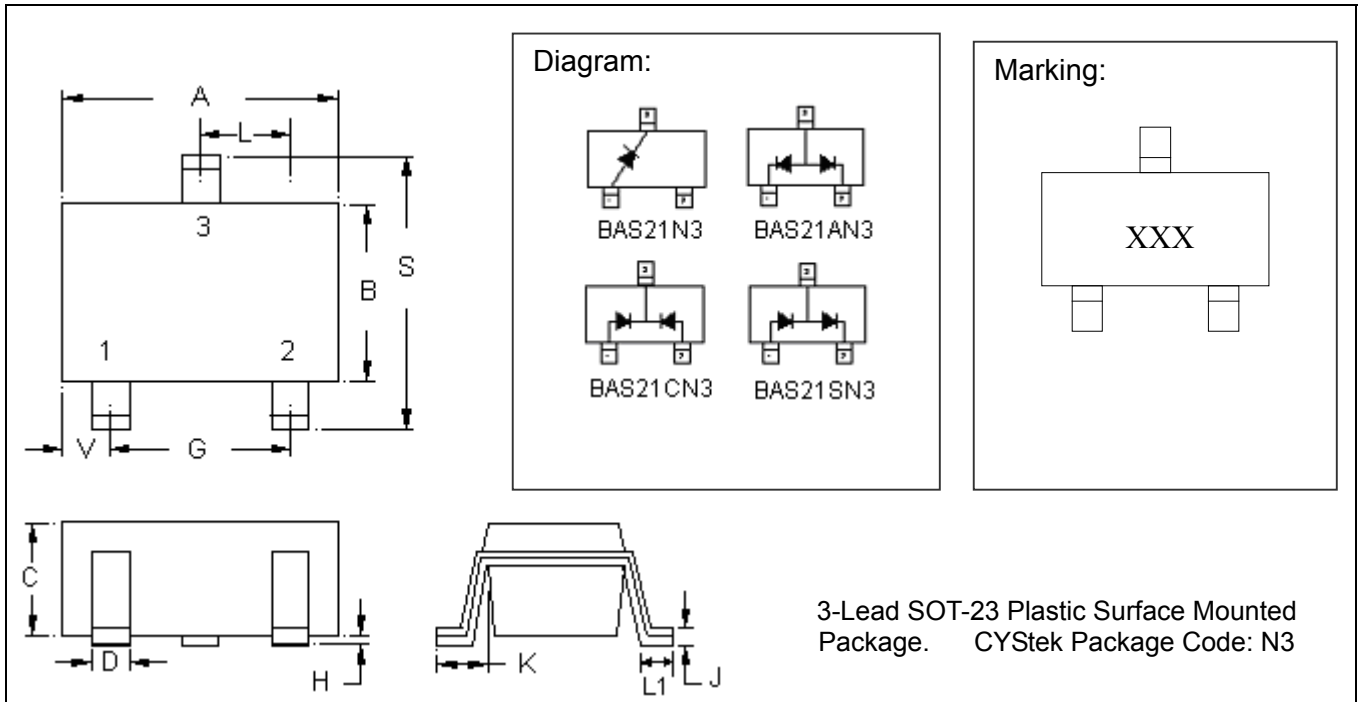

- BAS21 N3 : Single Diode (Marking Code JS)
- BAS21AN3 : Common Anode. (Marking Code JS2)
- BAS21CN3 : Common Cathode. (Marking Code JS3)
- BAS21SN3 : Series Connected. (Marking Code JS4)

DIM	Inches		Millimeters		DIM	Inches		Millimeters	
	Min.	Max.	Min.	Max.		Min.	Max.	Min.	Max.
A	0.1102	0.1204	2.80	3.04	J	0.0032	0.0079	0.08	0.20
B	0.0472	0.0669	1.20	1.70	K	0.0118	0.0266	0.30	0.67
C	0.0335	0.0512	0.89	1.30	L	0.0335	0.0453	0.85	1.15
D	0.0118	0.0197	0.30	0.50	S	0.0830	0.1161	2.10	2.95
G	0.0669	0.0910	1.70	2.30	V	0.0098	0.0256	0.25	0.65
H	0.0000	0.0040	0.00	0.10	L1	0.0118	0.0197	0.30	0.50

Notes: 1.Controlling dimension: millimeters.
 2.Maximum lead thickness includes lead finish thickness, and minimum lead thickness is the minimum thickness of base material.
 3.If there is any question with packing specification or packing method, please contact your local CYStek sales office.

Material:

- Lead: Pure tin plated.
- Mold Compound: Epoxy resin family, flammability solid burning class: UL94V-0.

Important Notice:

- All rights are reserved. Reproduction in whole or in part is prohibited without the prior written approval of CYStek.
- CYStek reserves the right to make changes to its products without notice.
- CYStek **semiconductor products are not warranted to be suitable for use in Life-Support Applications, or systems.**
- CYStek assumes no liability for any consequence of customer product design, infringement of patents, or application assistance.