

25Amp. Superfast High Voltage Rectifiers

MSR2560E2

$I_{F(AV)}$	25A
V_{RRM}	600V
I_{FSM}	150A
trr	30ns
T_j	175°C
$V_{F(Max)}$	2.5V

Features

- 175°C operating junction temperature
- Low leakage current
- Superfast recovery time
- Low switching loss, high efficiency
- High forward surge capability
- High temperature soldering guaranteed : 260°C/40s, 0.25”(6.35mm) from case
- Pb-free lead plating package

Mechanical Data

- Case: TO-220AC molded plastic
- Mounting Position: Any
- Weight: 1.85 grams, 0.065 ounce approximately
- Terminals: Pure tin plated, solderable per J-STD-002 and JESD22-B102
- Epoxy: UL 94V-0 rate flame retardant
- Polarity : As marked.

Equivalent Circuit

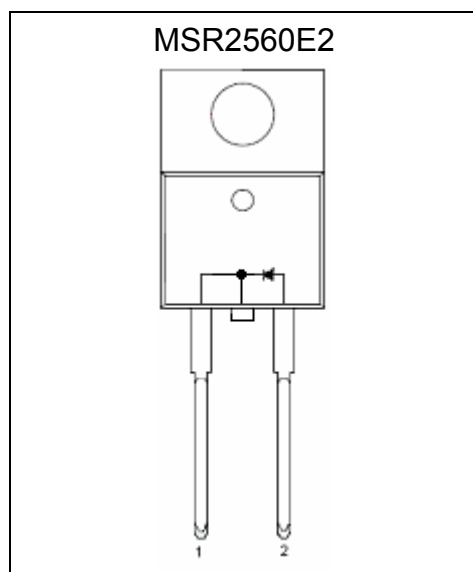

Outline

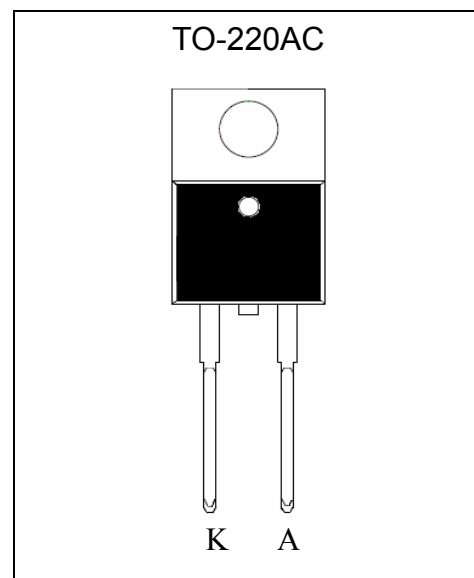

**Maximum Ratings and Electrical Characteristics**

(Rating at 25°C ambient temperature unless otherwise specified. Single phase, half wave, 60Hz, resistive or inductive load. For capacitive load, derate current by 20%.)

Parameter	Symbol	Min.	Typ.	Max.	Units
Maximum Recurrent peak reverse voltage	V_{RRM}			600	V
Maximum RMS voltage	V_{RMS}			420	V
Maximum DC blocking voltage	V_{DC}			600	V
Maximum instantaneous forward voltage at $I_F=25A$	V_F	$T_C=25^\circ C$	1.8	2.5	V
		$T_C=125^\circ C$	1.6	2.0	
Maximum Average forward rectified current @ $T_C=140^\circ C$	$I_{F(AV)}$			25	A
Non-repetitive peak forward surge current @ 8.3ms single half sine wave superimposed on rated load (JEDEC method)	I_{FSM}			150	A
Maximum instantaneous reverse current at	I_R	$V_R=600V, T_C=25^\circ C$		10	μA
		$V_R=600V, T_C=125^\circ C$		500	
Maximum reverse recovery time	t_{rr}			30	ns
Typical junction capacitance @ $f=1MHz$ and applied 4V reverse voltage	C_J		210		pF
Storage temperature range	T_{stg}	-65		+175	$^\circ C$
Operating junction temperature range	T_J	-65		+175	$^\circ C$

Thermal Data

Parameter	Symbol	Value	Unit
Maximum Thermal Resistance, Junction-to-case	$R_{th,j-c}$	1.4	$^\circ C/W$
Maximum Thermal Resistance, Junction-to-ambient	$R_{th,j-a}$	62.5	$^\circ C/W$

Ordering Information

Device	Package	Shipping
MSR2560E2	TO-220AC (RoHS compliant package)	50 pcs / Tube, 40 Tubes/Box

Typical Characteristics

Forward Current Derating Curve

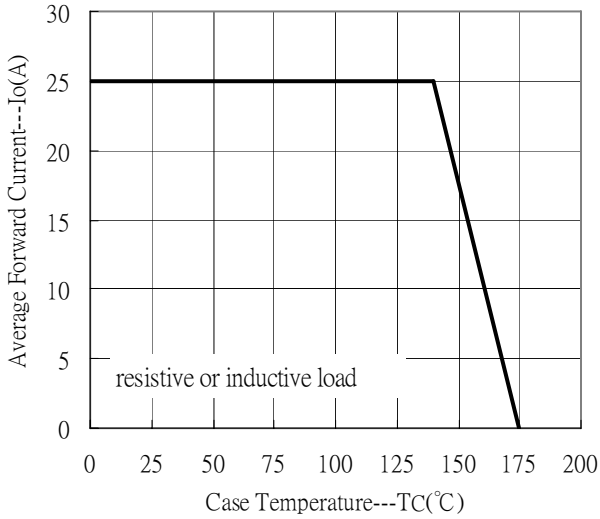

Forward Current vs Forward Voltage

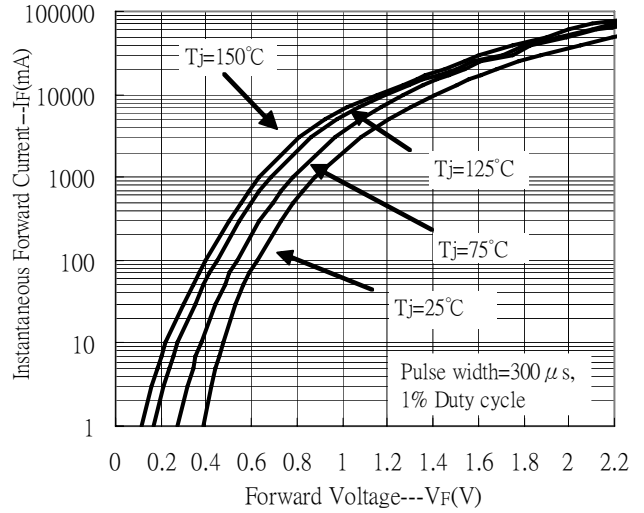

Reverse Leakage Current vs Reverse Voltage

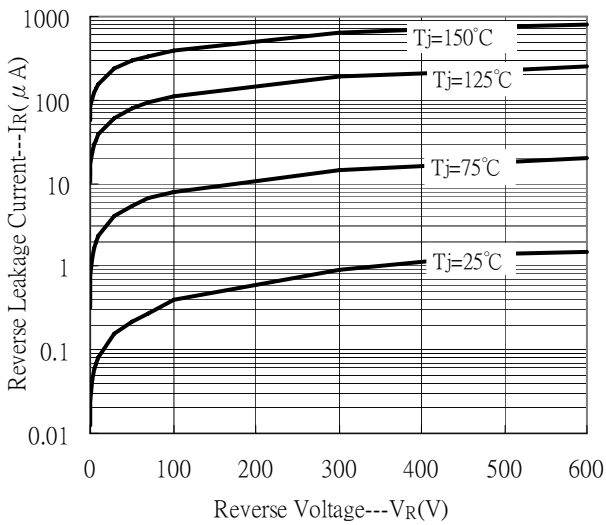

Junction Capacitance vs Reverse Voltage

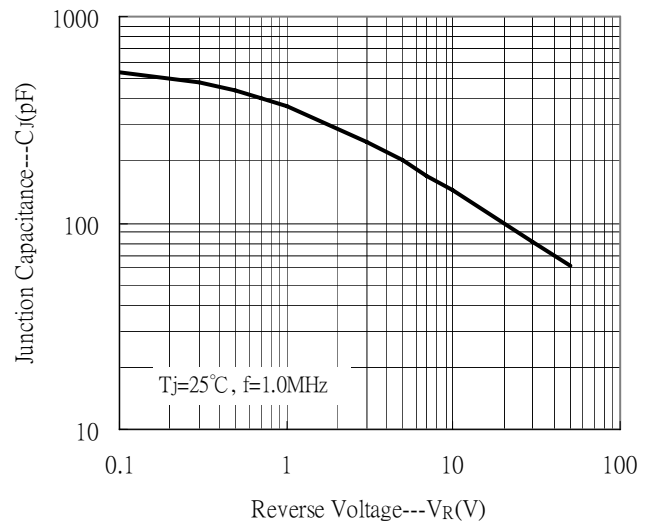

TO-220AC Dimension

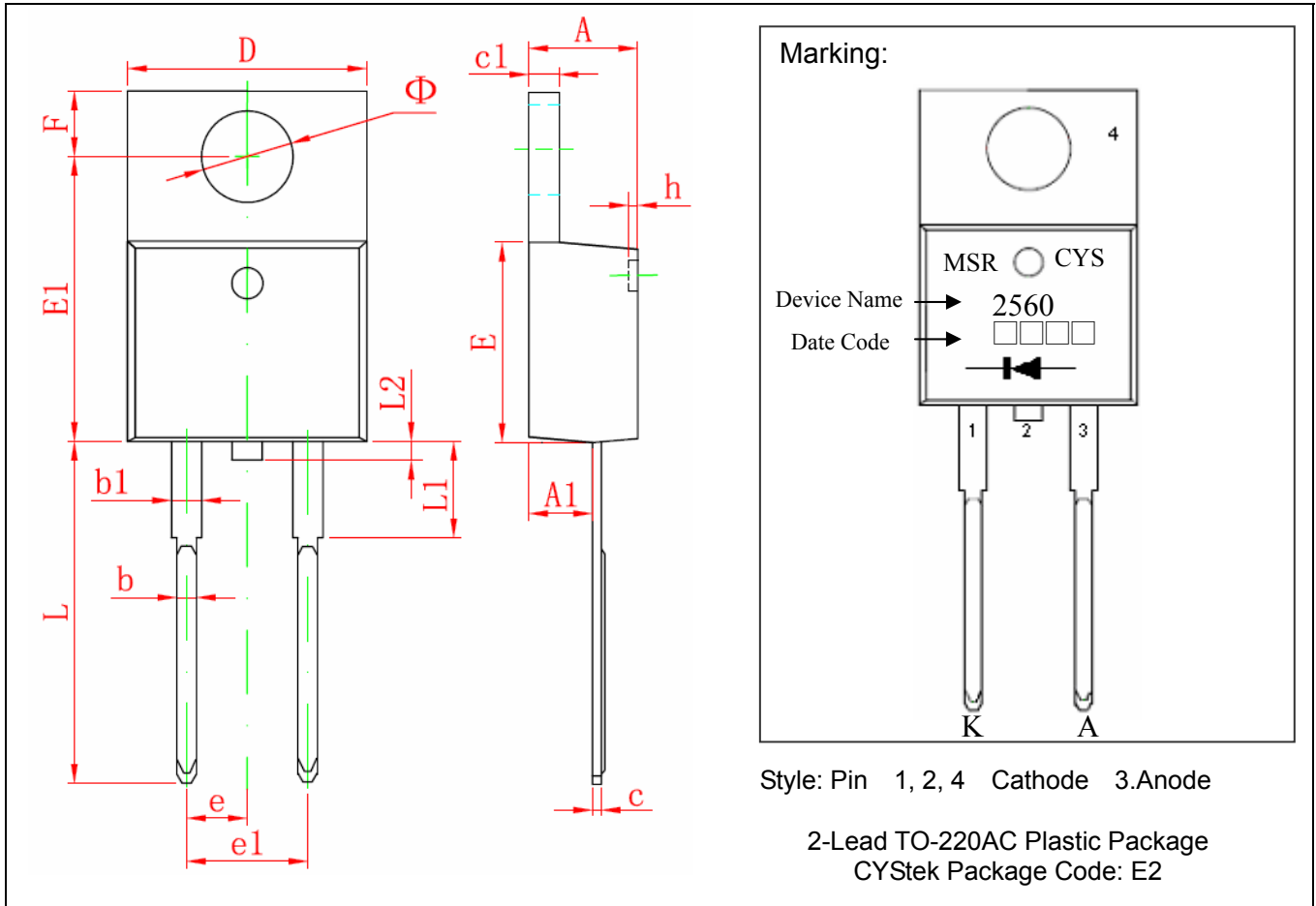

Marking:

Device Name → MSR CYS
 2560
 Date Code → [][][][]

Style: Pin 1, 2, 4 Cathode 3.Anode
 2-Lead TO-220AC Plastic Package
 CYStek Package Code: E2

DIM	Millimeters		Inches		DIM	Millimeters		Inches	
	Min.	Max.	Min.	Max.		Min.	Max.	Min.	Max.
A	4.470	4.670	0.176	0.184	e	2.540	TYP	0.100	TYP
A1	2.520	2.820	0.099	0.111	e1	4.980	5.180	0.196	0.204
b	0.710	0.910	0.028	0.036	F	2.590	2.890	0.102	0.114
b1	1.170	1.370	0.046	0.054	h	0.000	0.300	0.000	0.012
c	0.310	0.530	0.012	0.021	L	13.400	13.800	0.528	0.543
c1	1.170	1.370	0.046	0.054	L1	3.560	3.960	0.140	0.156
D	10.010	10.310	0.394	0.406	L2	0.000	1.000	0.000	0.039
E	8.500	8.900	0.335	0.350	Φ	3.735	3.935	0.147	0.155
E1	12.060	12.460	0.475	0.491					

Notes: 1.Controlling dimension: millimeters.
 2.Maximum lead thickness includes lead finish thickness, and minimum lead thickness is the minimum thickness of base material.
 3.If there is any question with packing specification or packing method, please contact your local CYStek sales office.

Material:

- Lead: Pure tin plated.
- Mold Compound: Epoxy resin family, flammability solid burning class: UL94V-0.

Important Notice:

- All rights are reserved. Reproduction in whole or in part is prohibited without the prior written approval of CYStek.
- CYStek reserves the right to make changes to its products without notice.
- CYStek **semiconductor products are not warranted to be suitable for use in Life-Support Applications, or systems.**
- CYStek assumes no liability for any consequence of customer product design, infringement of patents, or application assistance.