

1A Snubber Damping Rectifier

QJ

Features

- High current capability
- Smoothly soft reverse recovery time (trr)
- Low profile surface mounted package in order to minimize board space
- Pb-free lead plating and halogen-free package

Mechanical data

- Case : Molded plastic, JEDEC SOD-123.
- Epoxy : UL94-V0 rated flame retardant
- Terminals : Plated terminals, solderable per MIL-STD-202 method 208
- Polarity : Indicated by cathode band
- Mounting position : Any
- Weight : approx. 0.04 gram

Symbol

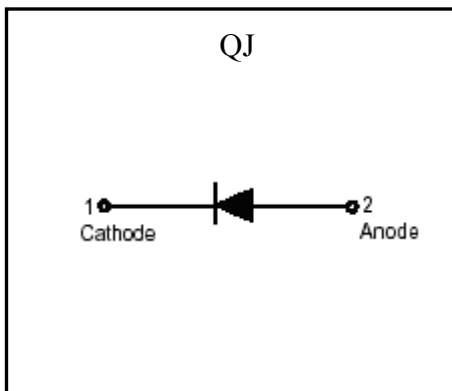

Outline

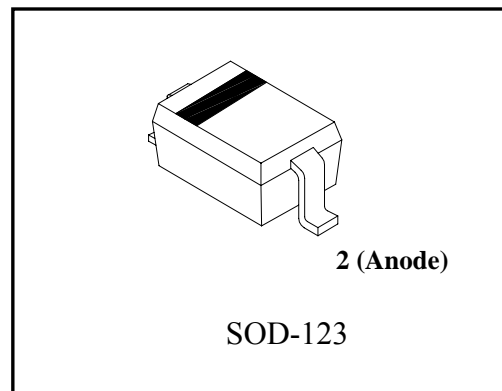

Ordering Information

Device	Package	Shipping
QJ-0-T1-G	SOD-123 (Pb-free lead plating and halogen-free package)	3000 pcs / tape & reel

- ↑ Environment friendly grade : S for RoHS compliant products, G for RoHS compliant and green compound products
- ↑ Packing spec, T1 : 3000 pcs / tape & reel, 7" reel
- ↑ Product rank, zero for no rank products
- ↑ Product name



Absolute Maximum Ratings (TA=25°C, unless otherwise noted)

Parameters	Conditions	Symbol	Value	Units
Repetitive peak reverse voltage		VRRM	600	V
RMS voltage		VRMS	420	V
Continuous reverse voltage		VR	600	V
Forward rectified current	Single phase half wave, 60Hz @TJ=25°C	IF(AV)	1	A
Repetitive Peak Forward Current	Single phase half wave, 60Hz @TJ=25°C	IFRM	1.57	A
Forward surge current	8.3ms single half sine-wave superimposed on rated load (JEDEC method)	IFSM	10	A
	tp ≤ 1μs		20	
Maximum reverse recovery time	IF=0.5A, IR=1.0A, IRR=0.25A	trr	3	μs
Storage temperature range		Tstg	-55~+150	°C
Operating junction temperature range		Tj	-55~+150	°C

Thermal Data

Parameter	Symbol	Value	Unit
Thermal Resistance, Junction-to-case, max	Rth,j-c	45	°C/W
Thermal Resistance, Junction-to-ambient, max (Note)	Rth,j-a	250	

Note: When mounted on FR-4 PCB with area measuring 10×10 mm

Characteristics (TA=25°C, unless otherwise noted)

Characteristic	Symbol	Condition	Min.	Typ	Max.	Unit
	VR	IR=100μA	600	-	-	V
Forward Voltage	VF 1	IF=100mA	-	-	0.95	V
	VF 2	IF=500mA	-	-	1.2	
Reverse Leakage Current	IR	VR=540V	-	-	100	nA
	IR	VR=540V, TA=125°C	-	-	10	μA
Junction Capacitance	CJ	VR=1V, f=1MHz	-	6	-	pF

Typical Characteristics

Power Derating Curve

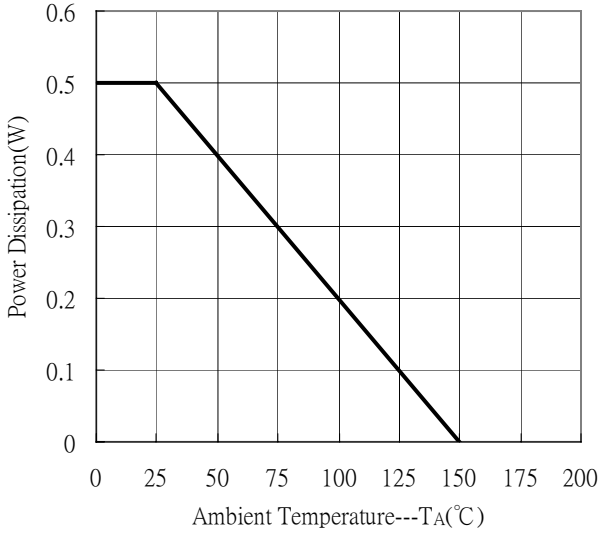

Forward Current vs Forward Voltage

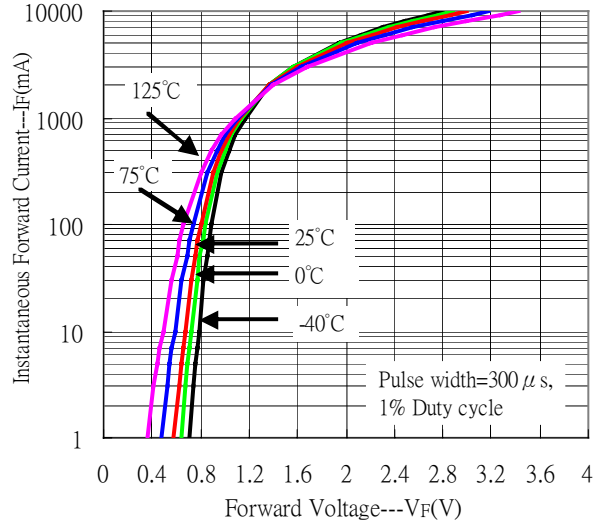

Reverse Leakage Current vs Reverse Voltage

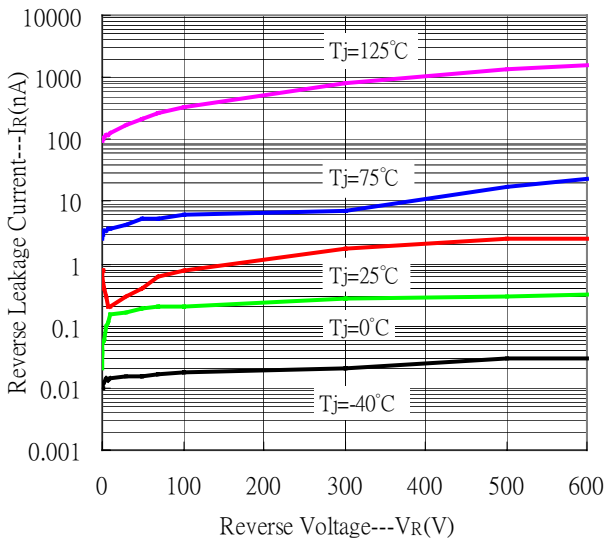

Junction Capacitance vs Reverse Voltage

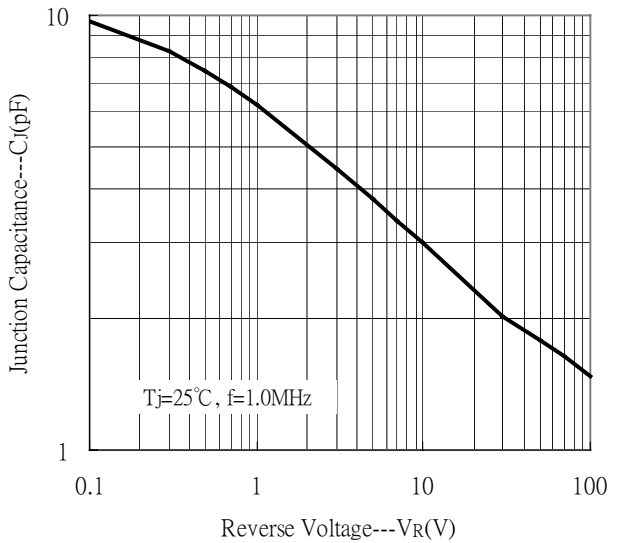

Maximum Safe Operating Area

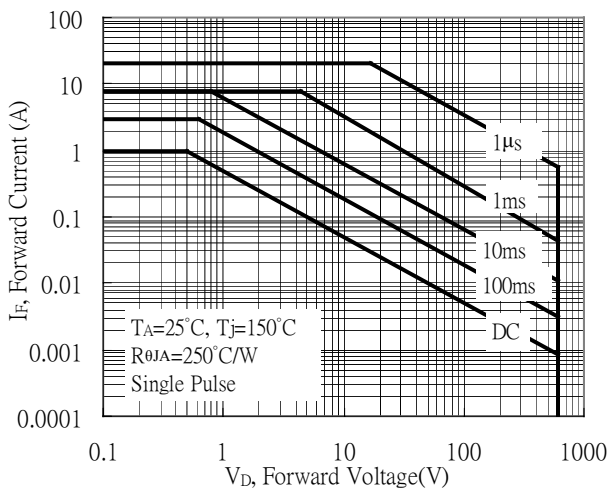

Recommended Soldering Footprint

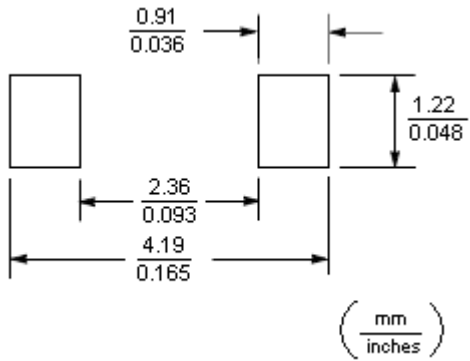

Reel Dimension

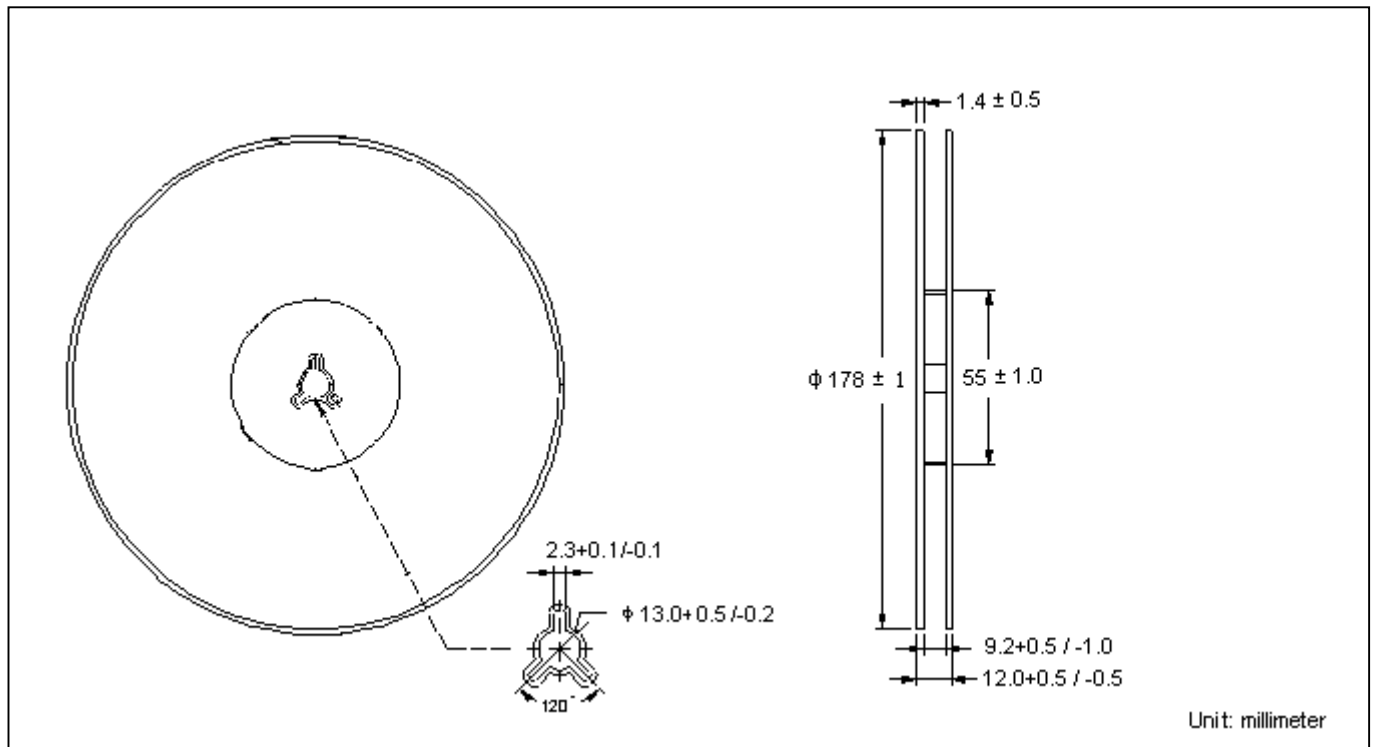

Carrier Tape Dimension

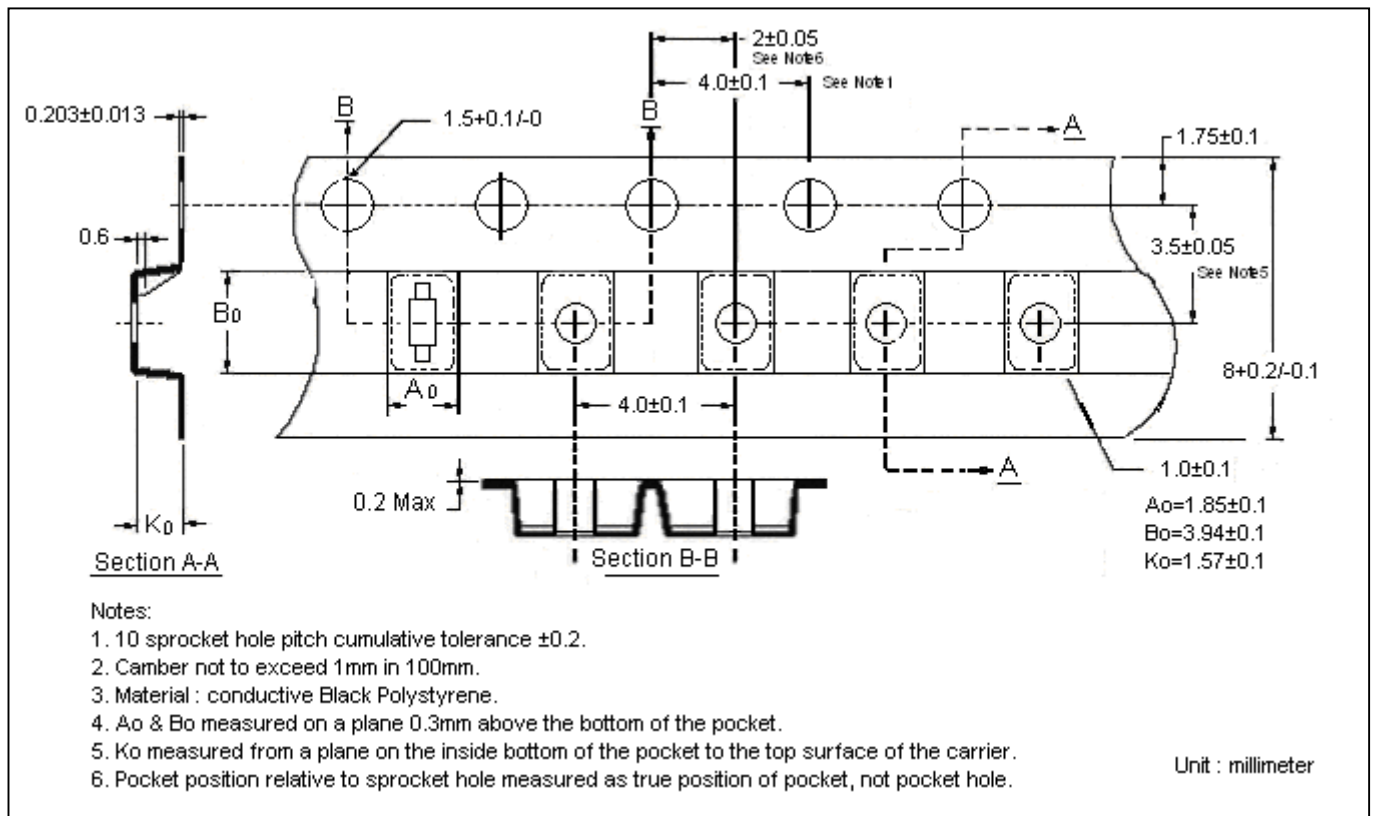

Recommended wave soldering condition

Product	Peak Temperature	Soldering Time
Pb-free devices	260 +0/-5 °C	5 +1/-1 seconds

Recommended temperature profile for IR reflow

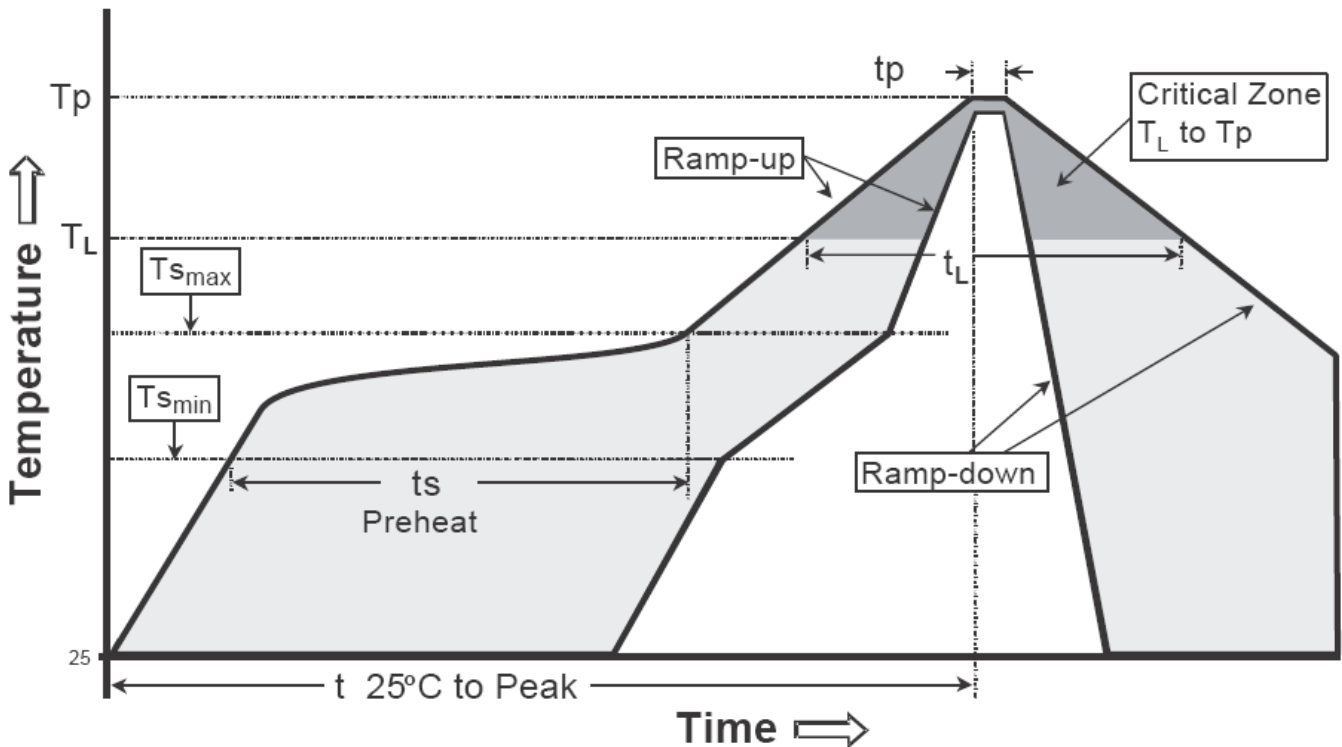

Profile feature	Sn-Pb eutectic Assembly	Pb-free Assembly
Average ramp-up rate (T _{smax} to T _p)	3°C/second max.	3°C/second max.
Preheat		
-Temperature Min(T _{s min})	100°C	150°C
-Temperature Max(T _{s max})	150°C	200°C
-Time(t _{s min} to t _{s max})	60-120 seconds	60-180 seconds
Time maintained above:		
-Temperature (T _L)	183°C	217°C
- Time (t _L)	60-150 seconds	60-150 seconds
Peak Temperature(T _P)	240 +0/-5 °C	260 +0/-5 °C
Time within 5°C of actual peak temperature(tp)	10-30 seconds	20-40 seconds
Ramp down rate	6°C/second max.	6°C/second max.
Time 25 °C to peak temperature	6 minutes max.	8 minutes max.

Note : All temperatures refer to topside of the package, measured on the package body surface.

SOD-123 Dimension

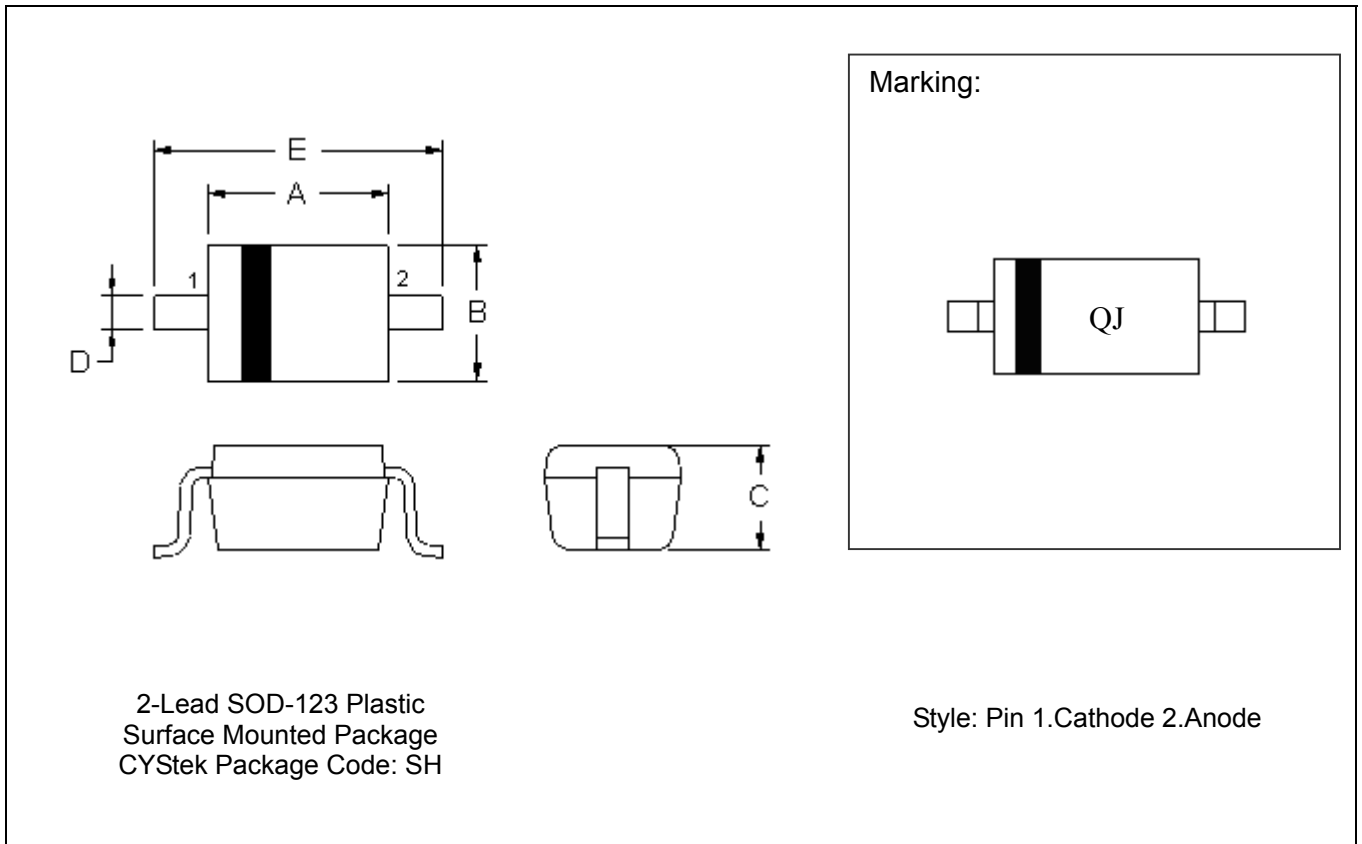

2-Lead SOD-123 Plastic
 Surface Mounted Package
 CYStek Package Code: SH

Style: Pin 1.Cathode 2.Anode

DIM	Inches		Millimeters		DIM	Inches		Millimeters	
	Min.	Max.	Min.	Max.		Min.	Max.	Min.	Max.
A	0.102	0.110	2.600	2.800	D	0.018	0.026	0.450	0.650
B	0.059	0.067	1.500	1.700	E	0.140	0.152	3.550	3.850
C	0.041	0.049	1.050	1.250					

Notes: 1.Controlling dimension : millimeters.
 2.Lead thickness specified per L/F drawing with solder plating.
 3.If there is any question with packing specification or packing method, please contact your local CYStek sales office.

Material:

- Lead: Pure tin plated.
- Mold Compound: Epoxy resin family, flammability solid burning class: UL94V-0.

Important Notice:

- All rights are reserved. Reproduction in whole or in part is prohibited without the prior written approval of CYStek.
- CYStek reserves the right to make changes to its products without notice.
- CYStek **semiconductor products are not warranted to be suitable for use in Life-Support Applications, or systems.**
- CYStek assumes no liability for any consequence of customer product design, infringement of patents, or application assistance.