

1A Snubber Damping Rectifier

QJM3, QJCTM3

Features

- High current capability
- Smoothly soft reverse recovery time (trr)
- Low profile surface mounted package in order to minimize board space
- Pb-free lead plating and halogen-free package

Pinning

Pin	Description	
	QJM3	QJCTM3
1	A	A1
2	K	K1, K2
3	NC	A2

Outline

Marking:

Type	Marking Code
QJM3	QJ
QJCTM3	QJCT

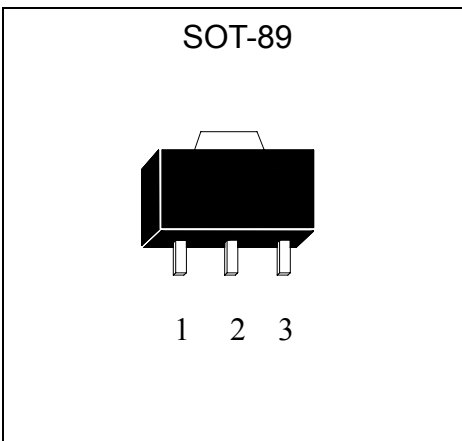
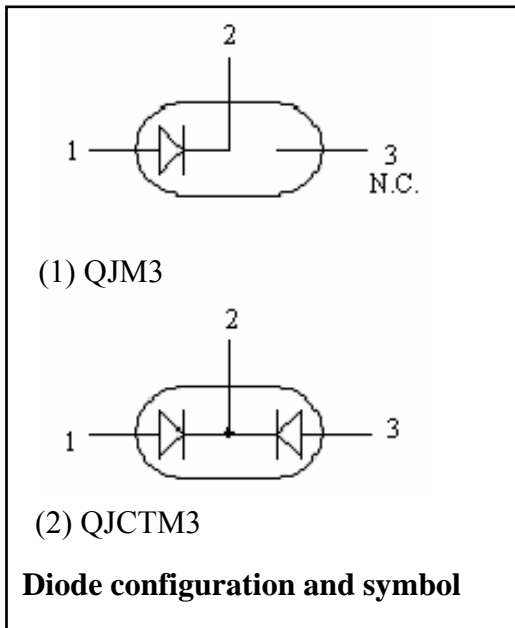

**Absolute Maximum Ratings** ($T_A=25^{\circ}\text{C}$, unless otherwise noted)

Parameters	Conditions	Symbol	Value	Units
Repetitive peak reverse voltage		V_{RRM}	600	V
RMS voltage		V_{RMS}	420	V
Continuous reverse voltage		V_R	600	V
Forward rectified current	Single phase half wave, 60Hz @ $T_J=25^{\circ}\text{C}$	$I_{F(AV)}$	1	A
Repetitive Peak Forward Current	Single phase half wave, 60Hz @ $T_J=25^{\circ}\text{C}$	I_{FRM}	1.57	A
Forward surge current	8.3ms single half sine-wave superimposed on rated load (JEDEC method)	I_{FSM}	10	A
Power Dissipation		P_D	0.6	W
	(Note 1)		1	
	(Note 2)		2	
Maximum reverse recovery time	$I_F=0.5\text{A}$, $I_R=1.0\text{A}$, $RR=0.25\text{A}$	trr	3	μs
Storage temperature range		T_{stg}	-55~+150	$^{\circ}\text{C}$
Operating junction temperature range		T_J	-55~+150	$^{\circ}\text{C}$

Note: *1 When mounted on FR-4 PCB with area measuring $10 \times 10 \times 1$ mm*2 When mounted on ceramic with area measuring $40 \times 40 \times 1$ mm**Characteristics** ($T_A=25^{\circ}\text{C}$, unless otherwise noted)

Characteristic	Symbol	Condition	Min.	Typ	Max.	Unit
Forward Voltage	V_R	$I_R=100\mu\text{A}$	600	-	-	V
	V_F 1	$I_F=100\text{mA}$	-	-	0.95	V
		$I_F=500\text{mA}$	-	-	1.2	
Reverse Leakage Current	I_R	$V_R=540\text{V}$	-	-	100	nA
	I_R	$V_R=540\text{V}$, $T_A=125^{\circ}\text{C}$	-	-	10	μA
Junction Capacitance	C_J	$V_R=1\text{V}$, $f=1\text{MHz}$	-	6	-	pF

Ordering Information

Device	Package	Shipping
QJM3-0-T2-G	SOT-89 (Pb-free lead plating and halogen-free package)	1000 pcs / Tape & Reel
QJCTM3-0-T2-G	SOT-89 (Pb-free lead plating and halogen-free package)	1000 pcs / Tape & Reel

Typical Characteristics

Power Derating Curves

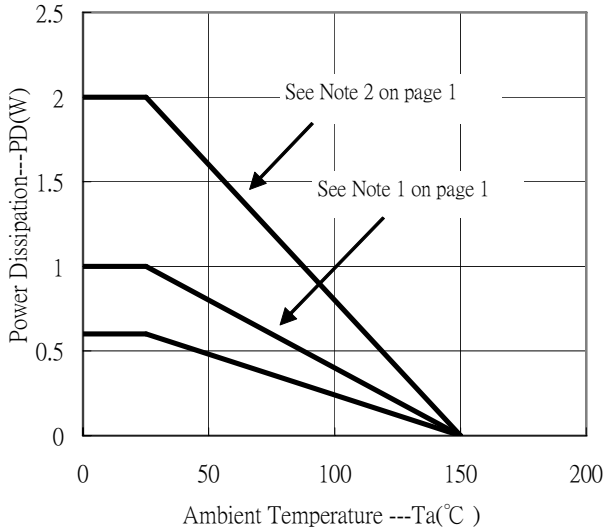

Forward Current vs Forward Voltage

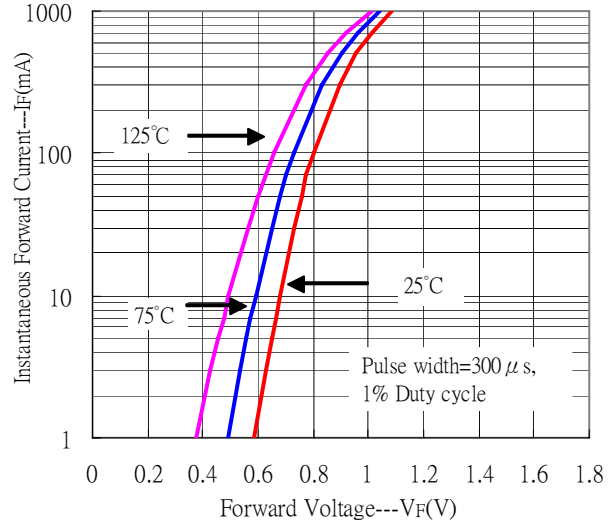

Reverse Leakage Current vs Reverse Voltage

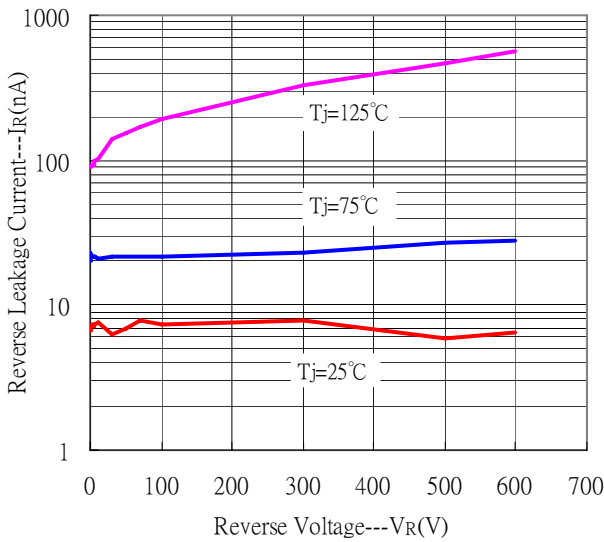

Junction Capacitance vs Reverse Voltage

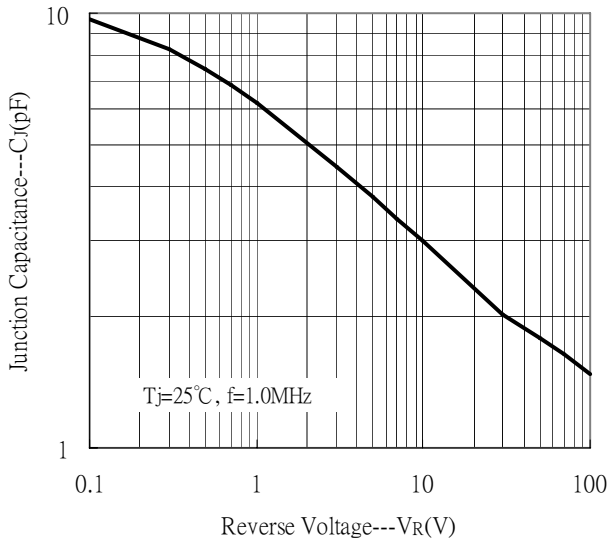

Recommended soldering footprint

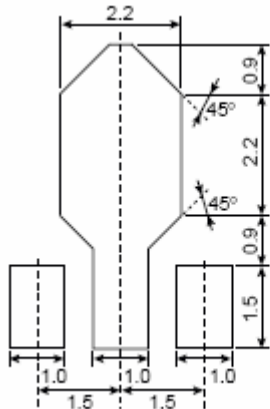

unit : mm

Reel Dimension

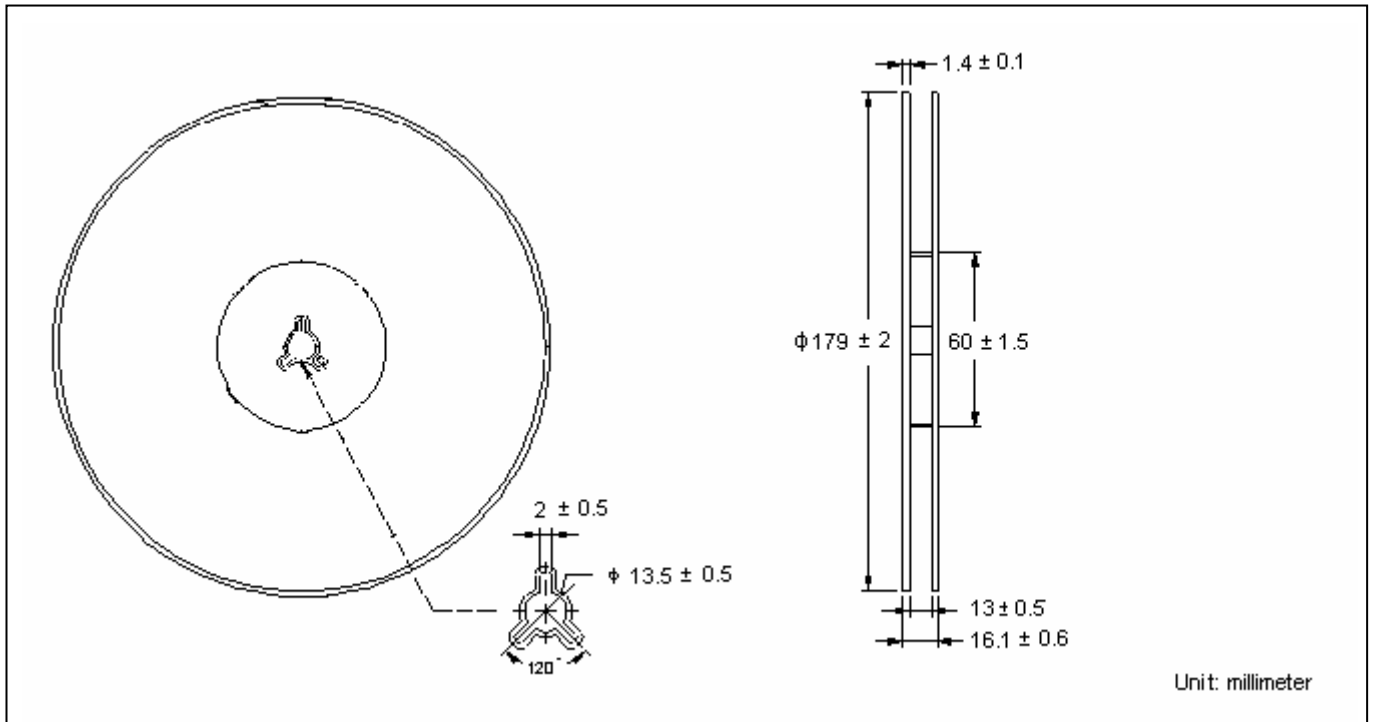

Carrier Tape Dimension

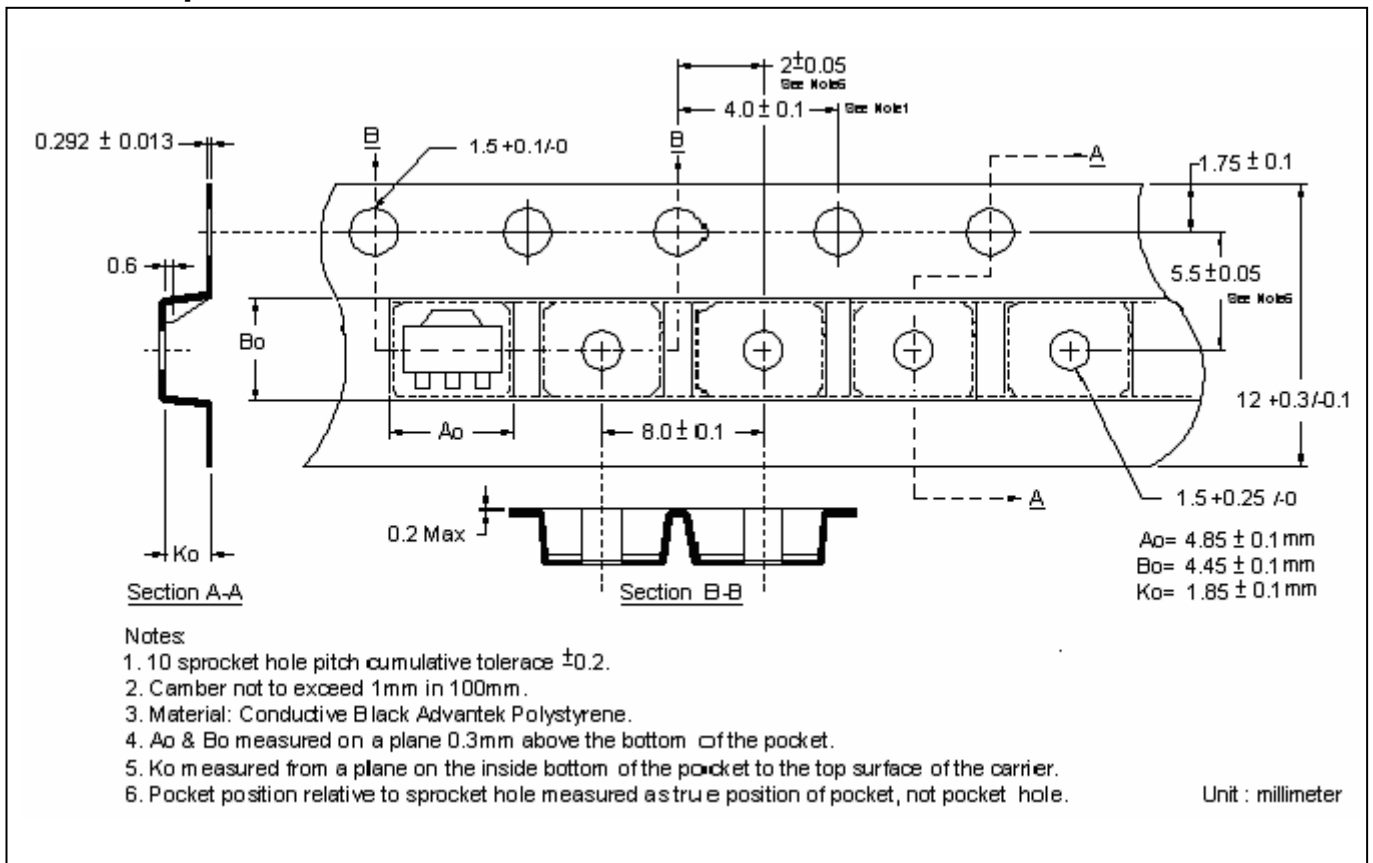

Recommended wave soldering condition

Product	Peak Temperature	Soldering Time
Pb-free devices	260 +0/-5 °C	5 +1/-1 seconds

Recommended temperature profile for IR reflow

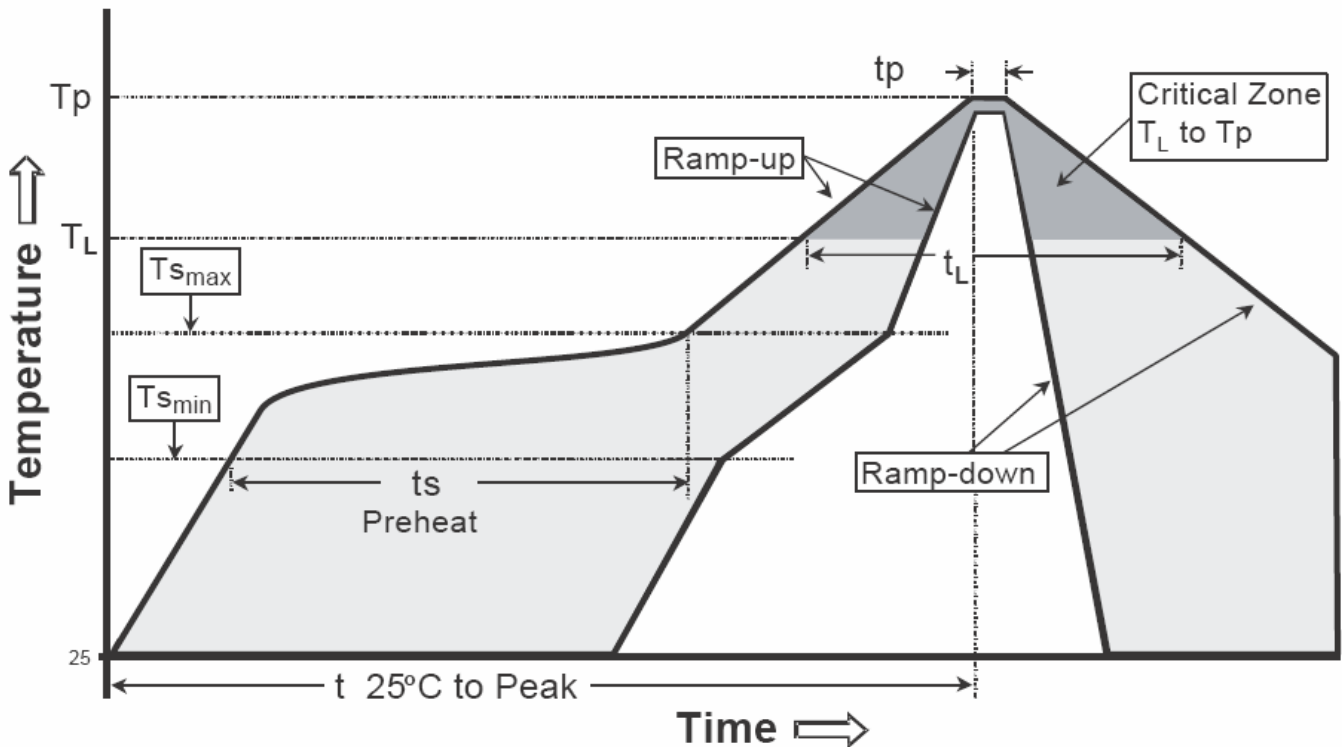

Profile feature	Sn-Pb eutectic Assembly	Pb-free Assembly
Average ramp-up rate (T _{smax} to T _p)	3°C/second max.	3°C/second max.
Preheat		
-Temperature Min(T _{s min})	100°C	150°C
-Temperature Max(T _{s max})	150°C	200°C
-Time(t _{s min} to t _{s max})	60-120 seconds	60-180 seconds
Time maintained above:		
-Temperature (T _L)	183°C	217°C
- Time (t _L)	60-150 seconds	60-150 seconds
Peak Temperature(T _P)	240 +0/-5 °C	260 +0/-5 °C
Time within 5°C of actual peak temperature(tp)	10-30 seconds	20-40 seconds
Ramp down rate	6°C/second max.	6°C/second max.
Time 25 °C to peak temperature	6 minutes max.	8 minutes max.

Note : All temperatures refer to topside of the package, measured on the package body surface.

SOT-89 Dimension

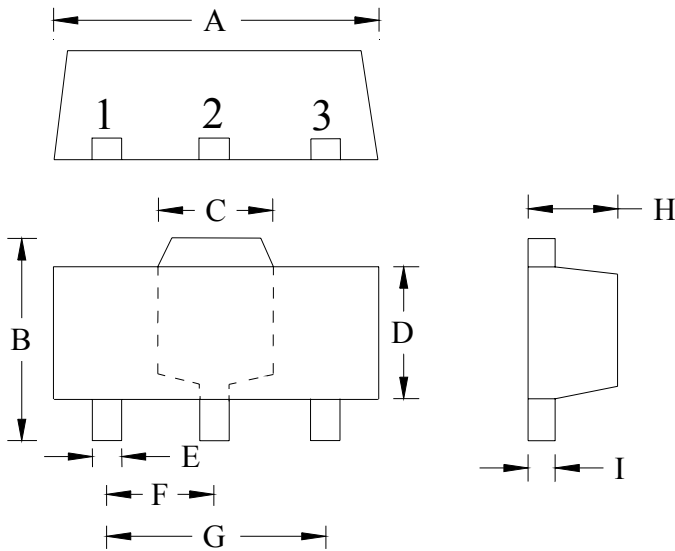

Marking:

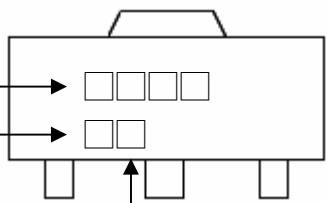

Product Code → □□□□
 Year code: → □□
 0→2010,
 1→2011,
 2→2012,
 ...etc.
 month code: 1~9, □
 A,B,C

Product Code : QJ for QJM3
 QJCT for QJCTM3

3-Lead SOT-89 Plastic
 Surface Mounted Package
 CYStek Package Code: M3

Style: QJM3 : Pin 1. Anode 2. Cathode 3. Not Connected
 QJCTM3: Pin 1. Anode 2. Cathode 3. Anode

*: Typical

DIM	Inches		Millimeters		DIM	Inches		Millimeters	
	Min.	Max.	Min.	Max.		Min.	Max.	Min.	Max.
A	0.1732	0.1811	4.40	4.60	F	0.0583	0.0598	1.48	1.527
B	0.1594	0.1673	4.05	4.25	G	0.1165	0.1197	2.96	3.04
C	0.0591	0.0663	1.50	1.70	H	0.0551	0.0630	1.40	1.60
D	0.0945	0.1024	2.40	2.60	I	0.0138	0.0161	0.35	0.41
E	0.01417	0.0201	0.36	0.51					

Notes: 1.Controlling dimension: millimeters.
 2.Maximum lead thickness includes lead finish thickness, and minimum lead thickness is the minimum thickness of base material.
 3.If there is any question with packing specification or packing method, please contact your local CYStek sales office.

Material:

- Lead: Pure tin plated.
- Mold Compound: Epoxy resin family, flammability solid burning class: UL94V-0.

Important Notice:

- All rights are reserved. Reproduction in whole or in part is prohibited without the prior written approval of CYStek.
- CYStek reserves the right to make changes to its products without notice.
- CYStek **semiconductor products are not warranted to be suitable for use in Life-Support Applications, or systems.**
- CYStek assumes no liability for any consequence of customer product design, infringement of patents, or application assistance.