

# N-Channel MOSFET

## MTN3418N3

BV <sub>DSS</sub>	30V
I <sub>D</sub>	1.9A
R <sub>DS(on)(max)</sub>	110mΩ

### Description

The MTN3418N3 is a N-channel enhancement-mode MOSFET.

### Features

- Low on-resistance
- High ESD
- High speed switching
- Low-voltage drive(4V)
- Easily designed drive circuits
- Easy to use in parallel
- Pb-free lead plating and halogen-free package

### Symbol

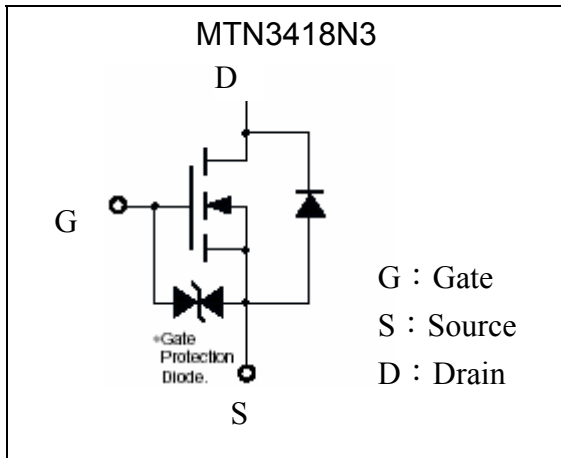

### Outline

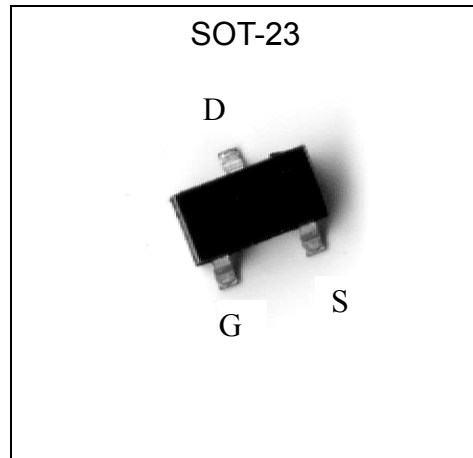

### Ordering Information

Device	Package	Shipping
MTN3418N3-0-T1-G	SOT-23 (Pb-free lead plating and halogen-free package)	3000 pcs / tape & reel

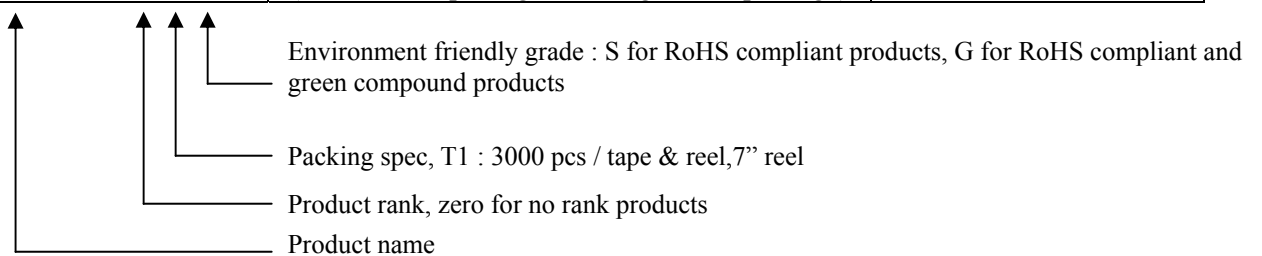

**Absolute Maximum Ratings (Ta=25°C)**

Parameter	Symbol	Limits	Unit
Drain-Source Voltage	V <sub>DSS</sub>	30	V
Gate-Source Voltage	V <sub>GSS</sub>	±20	V
Drain Current	Continuous	I <sub>D</sub>	1.9
	Pulsed	I <sub>DP</sub>	7.6 *1
Total Power Dissipation	P <sub>D</sub>	900 *2	mW
ESD susceptibility		750 *3	V
Channel Temperature	T <sub>CH</sub>	+150	°C
Storage Temperature	T <sub>stg</sub>	-55~+150	°C

Note : \*1. Pulse Width ≤ 300µs, Duty cycle ≤2%

\*2. When the device is mounted on a ceramic board with area measuring 30mm × 30mm × 0.8mm

\*3. Human body model, 1.5kΩ in series with 100pF

**Electrical Characteristics (Ta=25°C)**

Symbol	Min.	Typ.	Max.	Unit	Test Conditions
<b>Static</b>					
BV <sub>DSS</sub> *	30	-	-	V	V <sub>GS</sub> =0, I <sub>D</sub> =10µA
V <sub>GS(th)</sub>	1	-	2.5	V	V <sub>DS</sub> =V <sub>GS</sub> , I <sub>D</sub> =250µA
I <sub>GSS</sub>	-	-	±5	µA	V <sub>GS</sub> =±20V, V <sub>DS</sub> =0
I <sub>DSS</sub>	-	-	500	nA	V <sub>DS</sub> =30V, V <sub>GS</sub> =0
R <sub>DS(ON)</sub> *	-	133	150	mΩ	I <sub>D</sub> =950mA, V <sub>GS</sub> =4V
	-	90	110		I <sub>D</sub> =1.9A, V <sub>GS</sub> =10V
G <sub>FS</sub>	400	-	-	mS	V <sub>DS</sub> =10V, I <sub>D</sub> =500mA
<b>Dynamic</b>					
C <sub>iss</sub>	-	215	-	pF	V <sub>DS</sub> =10V, V <sub>GS</sub> =0, f=1MHz
C <sub>oss</sub>	-	54	-		
C <sub>rss</sub>	-	34	-		
<b>Source-Drain Diode</b>					
*V <sub>SD</sub>	-	-	1	V	V <sub>GS</sub> =0V, I <sub>SD</sub> =1A

\*Pulse Test : Pulse Width ≤380µs, Duty Cycle≤2%

**Recommended Soldering Footprint**

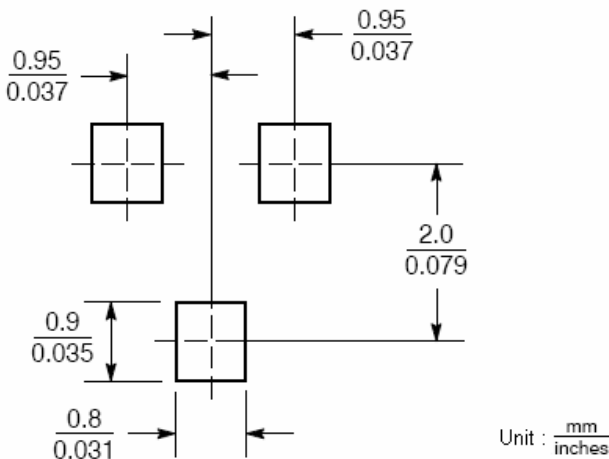

**Typical Characteristics**

Typical Output Characteristics

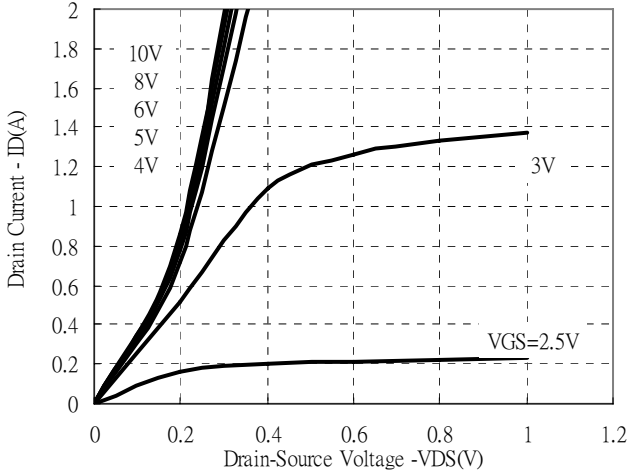

Static Drain-Source On-resistance vs Ambient Temperature

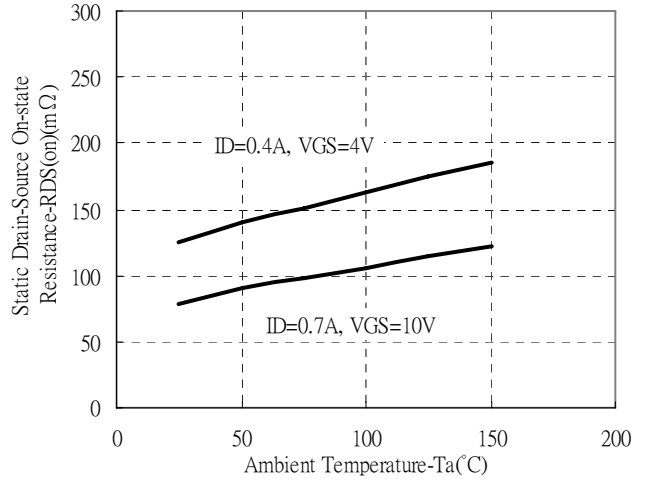

Static Drain-Source On-State resistance vs Drain Current

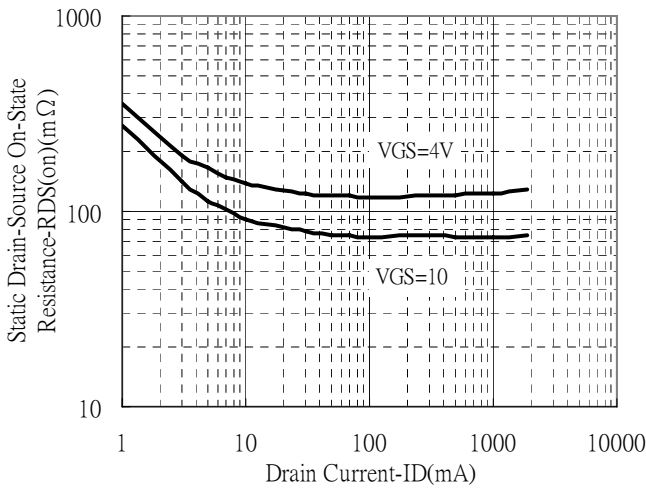

Drain Current vs Gate-Source Voltage

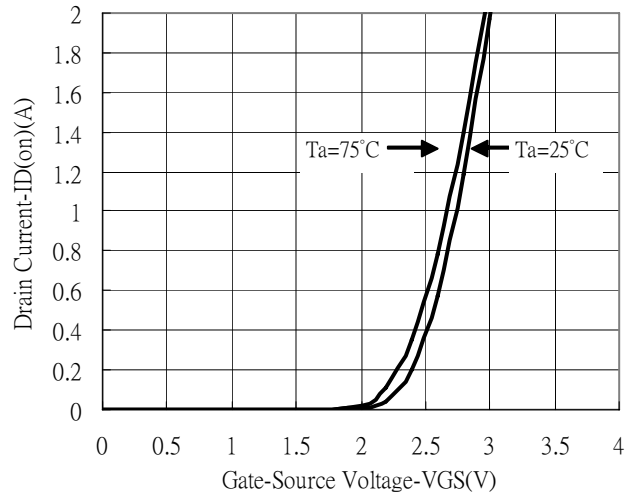

Static Drain-Source On-State Resistance vs Gate-Source Voltage

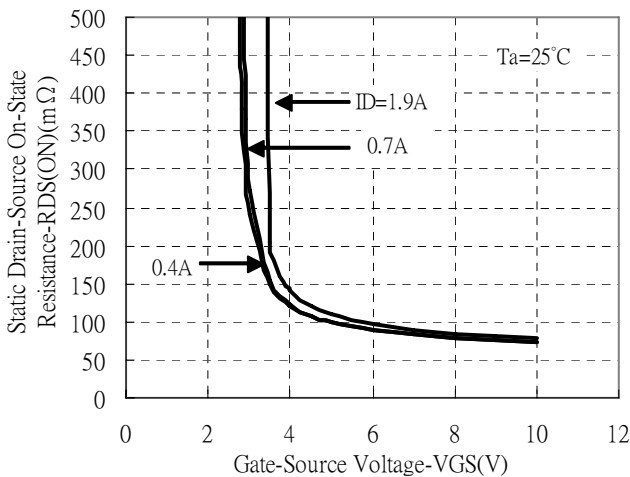

Forward Drain Current vs Source-Drain Voltage

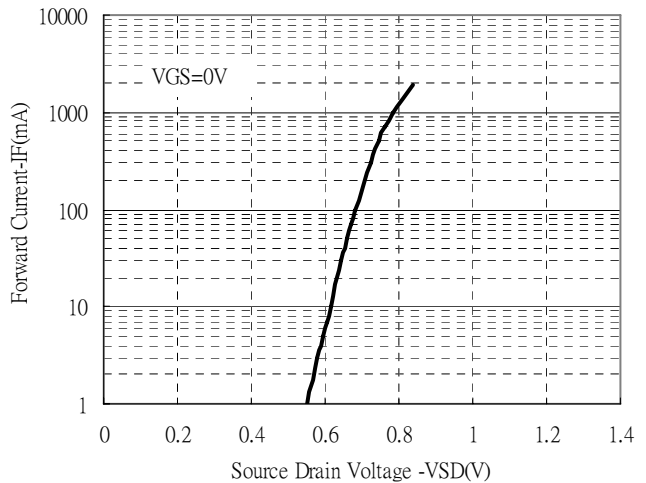

**Characteristic Curves(Cont.)**

Capacitance vs Reverse Voltage

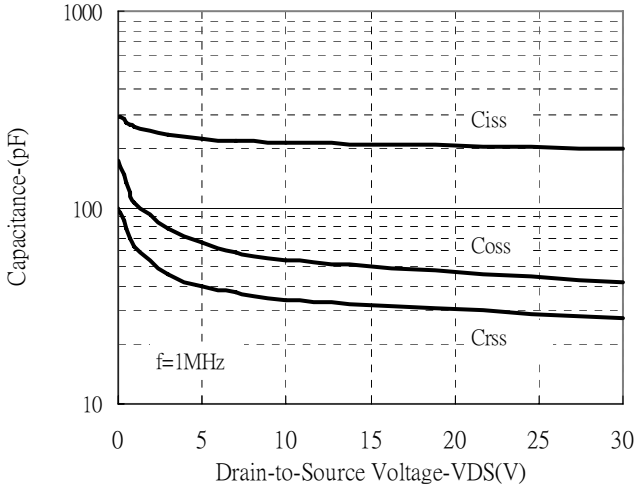

Forward Transfer Admittance vs Drain Current

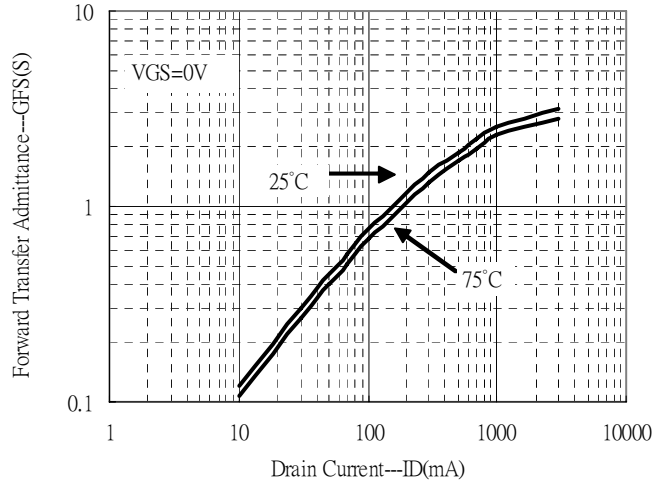

Maximum Safe Operating Area

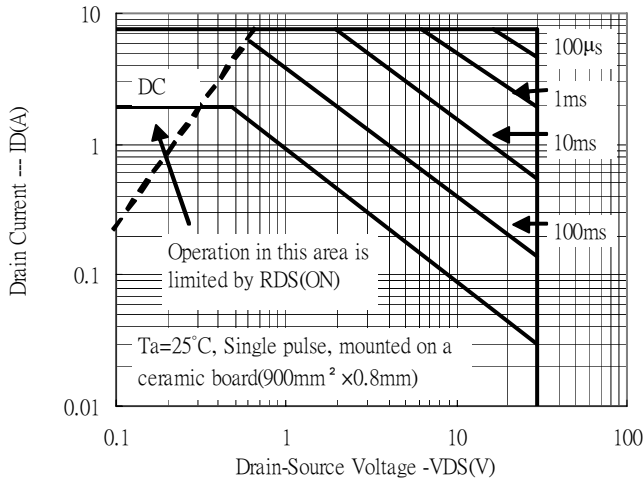

Power Derating Curve

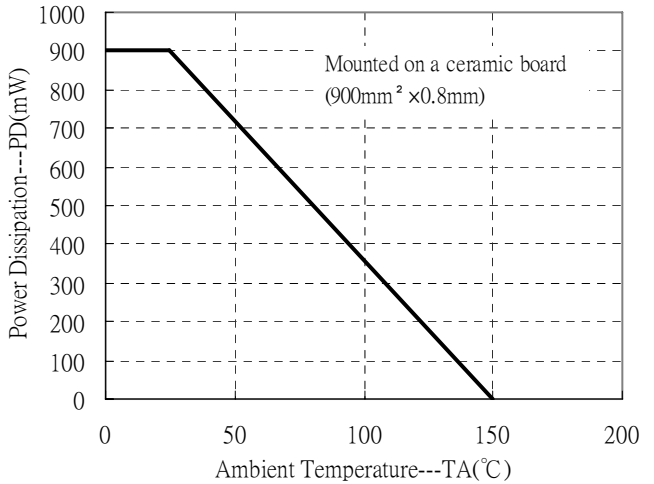

Gate Threshold Voltage vs Ambient Temperature

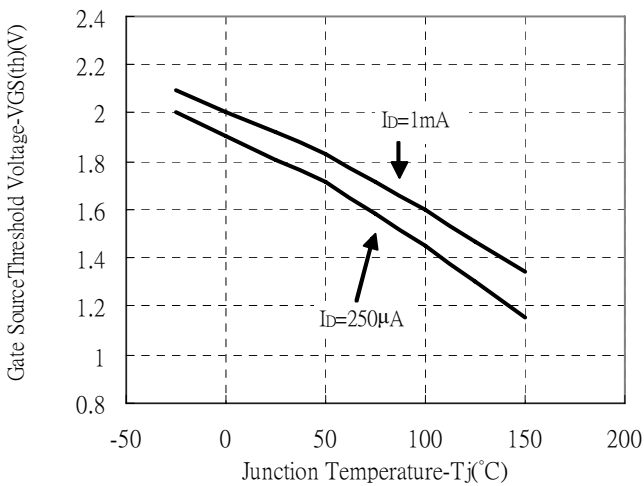

**Reel Dimension**

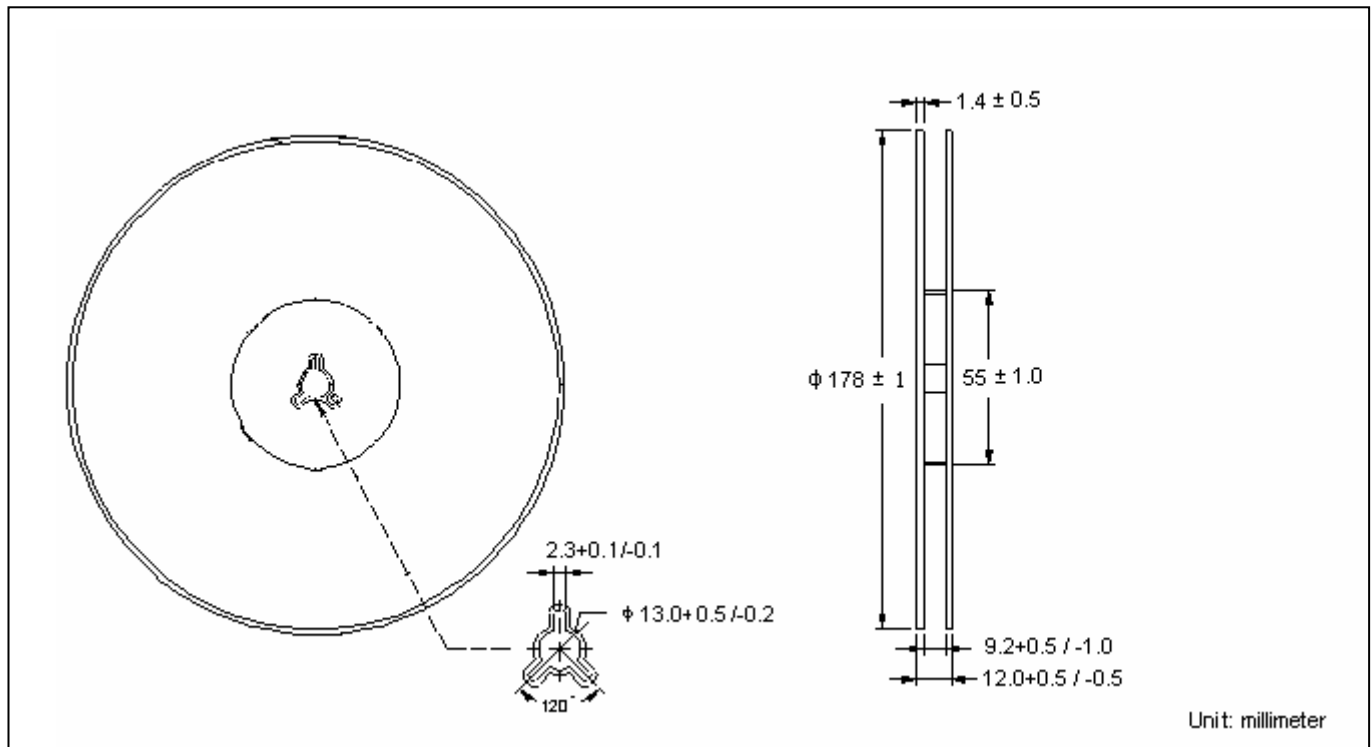

**Carrier Tape Dimension**

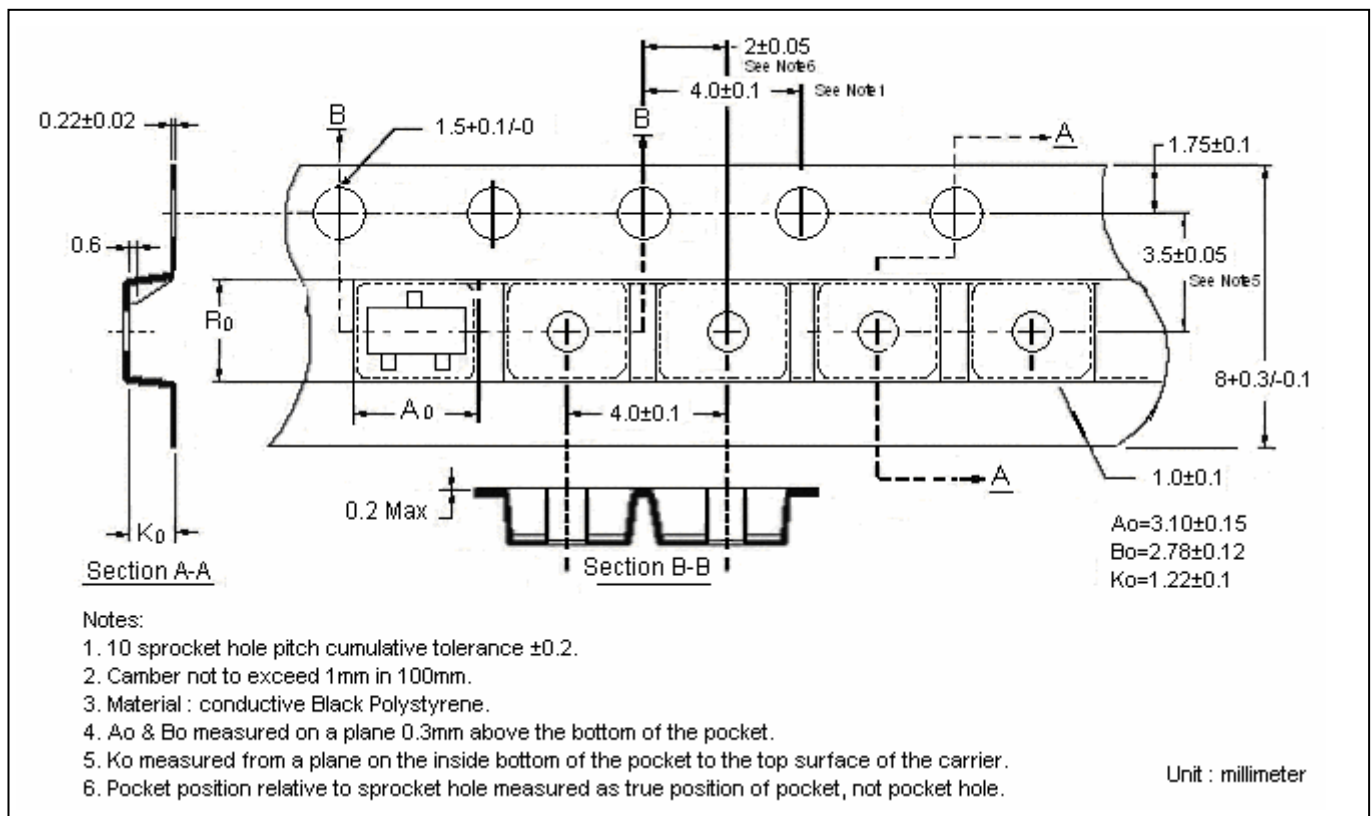

**Recommended wave soldering condition**

Product	Peak Temperature	Soldering Time
Pb-free devices	260 +0/-5 °C	5 +1/-1 seconds

**Recommended temperature profile for IR reflow**

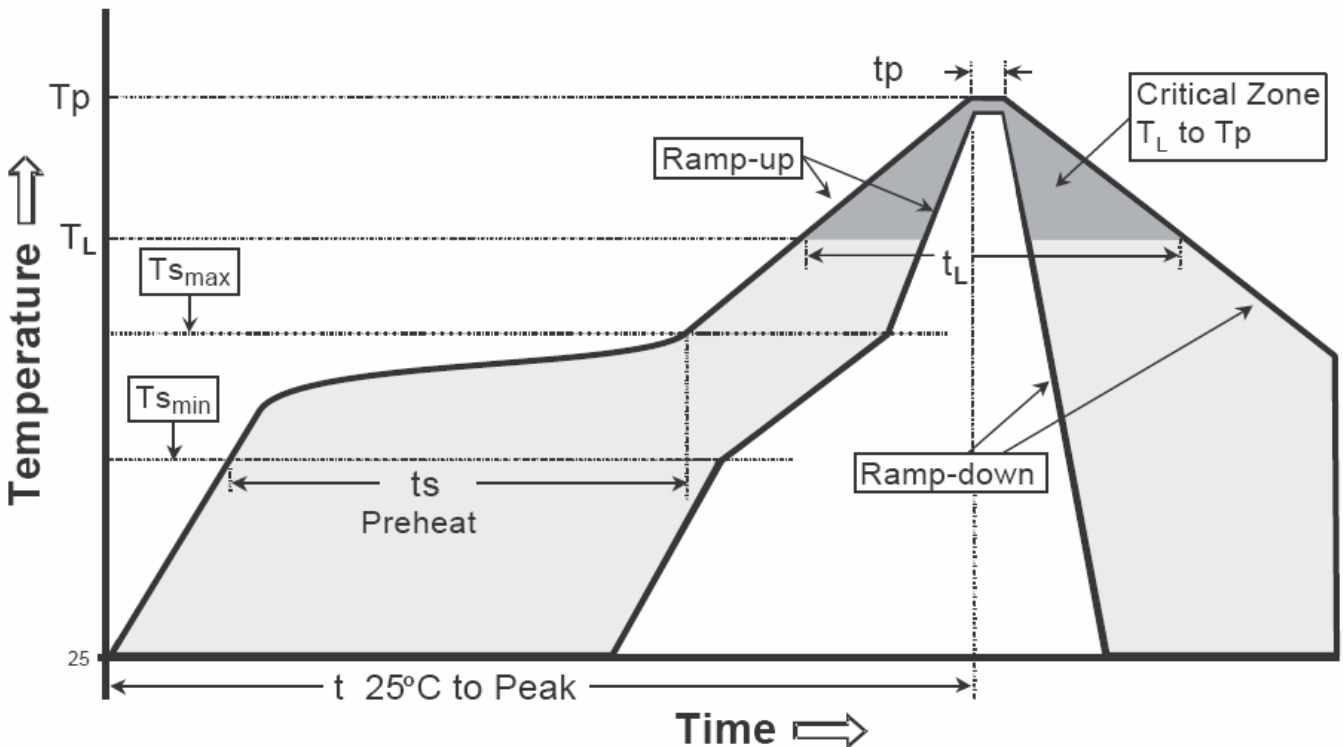

Profile feature	Sn-Pb eutectic Assembly	Pb-free Assembly
Average ramp-up rate (Ts <sub>max</sub> to T <sub>p</sub> )	3°C/second max.	3°C/second max.
Preheat		
-Temperature Min(T <sub>s min</sub> )	100°C	150°C
-Temperature Max(T <sub>s max</sub> )	150°C	200°C
-Time(t <sub>s min</sub> to t <sub>s max</sub> )	60-120 seconds	60-180 seconds
Time maintained above:		
-Temperature (T <sub>L</sub> )	183°C	217°C
- Time (t <sub>L</sub> )	60-150 seconds	60-150 seconds
Peak Temperature(T <sub>p</sub> )	240 +0/-5 °C	260 +0/-5 °C
Time within 5°C of actual peak temperature(tp)	10-30 seconds	20-40 seconds
Ramp down rate	6°C/second max.	6°C/second max.
Time 25 °C to peak temperature	6 minutes max.	8 minutes max.

Note : All temperatures refer to topside of the package, measured on the package body surface.

**SOT-23 Dimension**

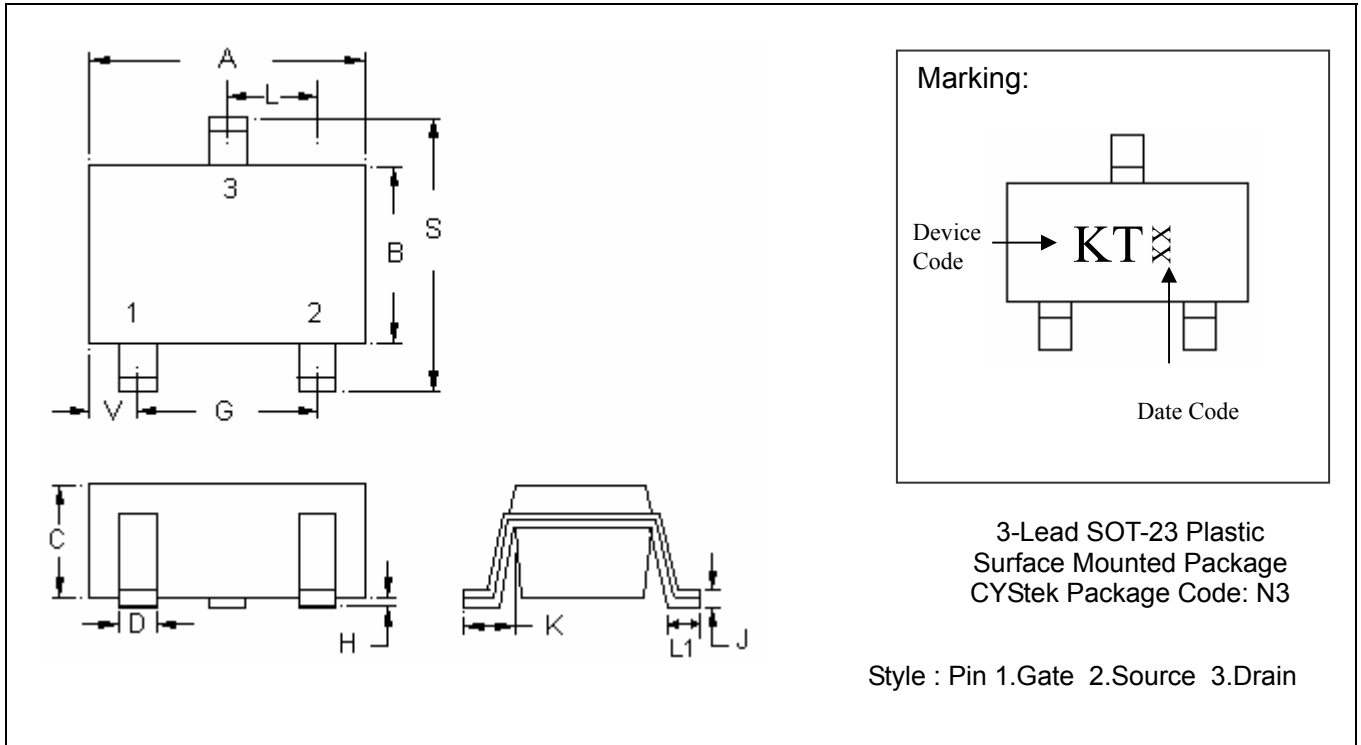

\*:Typical

DIM	Inches		Millimeters		DIM	Inches		Millimeters	
	Min.	Max.	Min.	Max.		Min.	Max.	Min.	Max.
A	0.1102	0.1204	2.80	3.04	J	0.0032	0.0079	0.08	0.20
B	0.0472	0.0669	1.20	1.70	K	0.0118	0.0266	0.30	0.67
C	0.0335	0.0512	0.89	1.30	L	0.0335	0.0453	0.85	1.15
D	0.0118	0.0197	0.30	0.50	S	0.0830	0.1161	2.10	2.95
G	0.0669	0.0910	1.70	2.30	V	0.0098	0.0256	0.25	0.65
H	0.0000	0.0040	0.00	0.10	L1	0.0118	0.0197	0.30	0.50

Notes : 1.Controlling dimension : millimeters.  
 2.Maximum lead thickness includes lead finish thickness, and minimum lead thickness is the minimum thickness of base material.  
 3.If there is any question with packing specification or packing method, please contact your local CYStek sales office.

**Material :**

- Lead : Pure tin plated.
- Mold Compound : Epoxy resin family, flammability solid burning class:UL94V-0.

**Important Notice:**

- All rights are reserved. Reproduction in whole or in part is prohibited without the prior written approval of CYStek.
- CYStek reserves the right to make changes to its products without notice.
- CYStek **semiconductor products are not warranted to be suitable for use in Life-Support Applications, or systems.**
- CYStek assumes no liability for any consequence of customer product design, infringement of patents, or application assistance.