

N-Channel Enhancement Mode Power MOSFET

MTB06N03E3

BV_{DSS}		30V
I_D		102A
$R_{DSON(TYP)}$	$V_{GS}=10V, I_D=30A$	4.3m Ω
	$V_{GS}=4.5V, I_D=24A$	6.6m Ω

Features

- Simple Drive Requirement
- Repetitive Avalanche Rated
- Fast Switching Characteristic
- Pb-free lead plating and RoHS compliant package

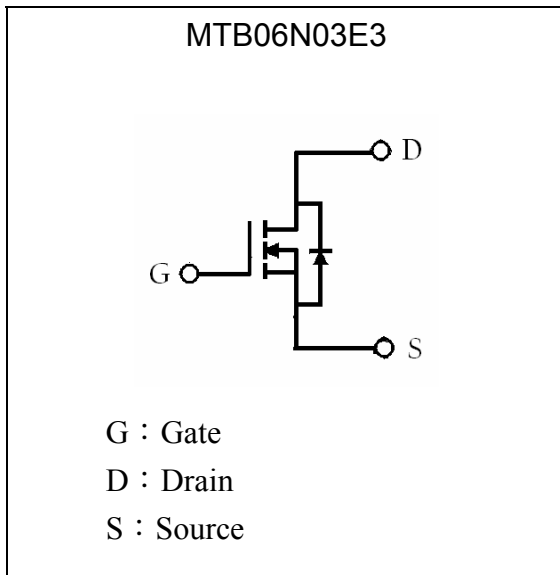
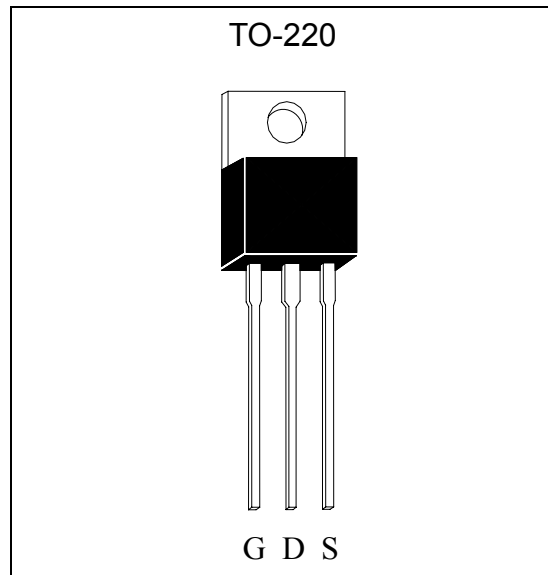
Symbol

Outline

Absolute Maximum Ratings ($T_a=25^\circ\text{C}$)

Parameter		Symbol	Limits	Unit
Drain-Source Voltage		V_{DS}	30	V
Gate-Source Voltage		V_{GS}	± 20	
Continuous Drain Current @ $V_{GS}=10V, T_c=25^\circ\text{C}$		I_D	102	A
Continuous Drain Current @ $V_{GS}=10V, T_c=100^\circ\text{C}$		I_D	72	
Pulsed Drain Current		I_{DM}	408 *1	
Avalanche Current		I_{AS}	16	
Avalanche Energy	$L=2\text{mH}, I_D=16A, V_{DD}=25V$	E_{AS}	256	mJ
Repetitive Avalanche Energy	$L=0.05\text{mH}$	E_{AR}	25	
Total Power Dissipation	$T_c=25^\circ\text{C}$	P_D	94	W
	$T_c=100^\circ\text{C}$		47	
Operating Junction and Storage Temperature		T_j, T_{stg}	-55~+175	$^\circ\text{C}$

Note : *1. Pulse width limited by maximum junction temperature.



Thermal Data

Parameter	Symbol	Value	Unit
Thermal Resistance, Junction-to-case, max	R _{th,j-c}	1.6	°C/W
Thermal Resistance, Junction-to-ambient, max	R _{th,j-a}	62.5	°C/W

Characteristics (T_j=25°C, unless otherwise specified)

Symbol	Min.	Typ.	Max.	Unit	Test Conditions
Static					
B _V DSS	30	-	-	V	V _{GS} =0V, I _D =250μA
V _{GS(th)}	1	1.5	3		V _{DS} = V _{GS} , I _D =250μA
I _{GSS}	-	-	±100	nA	V _{GS} =±20, V _{DS} =0V
I _{DSS}	-	-	1	μA	V _{DS} =30V, V _{GS} =0V
	-	-	25		V _{DS} =30V, V _{GS} =0V, T _j =125°C
*R _{DS(ON)}	-	4.3	5.3	mΩ	V _{GS} =10V, I _D =30A
	-	6.6	8.6		V _{GS} =4.5V, I _D =24A
*G _{FS}	-	28	-	S	V _{DS} =5V, I _D =24A
Dynamic					
*Q _g (V _{GS} =10V)	-	53	-	nC	V _{DS} =15V, I _D =30A, V _{GS} =10V
*Q _g (V _{GS} =5V)	-	26	-		
*Q _{gs}	-	7	-		
*Q _{gd}	-	12	-		
*t _{d(ON)}	-	22	-	ns	V _{DS} =15V, I _D =25A, V _{GS} =10V, R _{GS} =2.7Ω
*t _r	-	16	-		
*t _{d(OFF)}	-	65	-		
*t _f	-	10	-		
C _{iss}	-	2678	-	pF	V _{GS} =0V, V _{DS} =25V, f=1MHz
C _{oss}	-	241	-		
C _{rss}	-	204	-		
Source-Drain Diode					
*I _S	-	-	102	A	
*I _{SM}	-	-	408		
*V _{SD}	-	0.86	1.2	V	I _F =30A, V _{GS} =0V
*t _{rr}	-	30	-	ns	I _F =30A, V _{GS} =0V, dI _F /dt=100A/μs
*Q _{rr}	-	25	-	nC	

*Pulse Test : Pulse Width ≤300μs, Duty Cycle≤2%

Ordering Information

Device	Package	Shipping
MTB06N03E3-0-UB-S	TO-220 (Pb-free lead plating and RoHS compliant package)	50 pcs/tube, 20 tubes/box, 4 boxes / carton

Typical Characteristics

Typical Output Characteristics

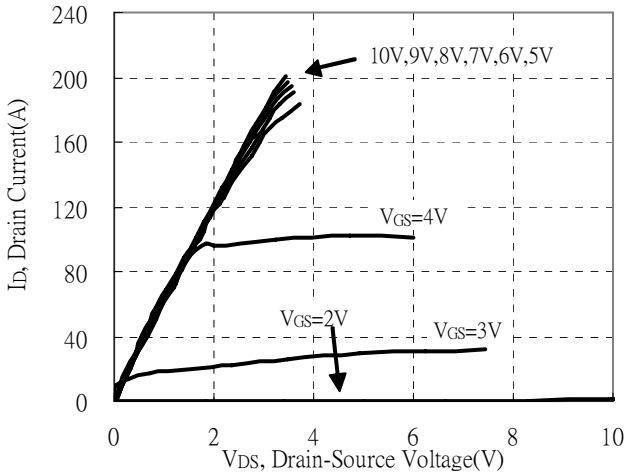

Brekdown Voltage vs Junction Temperature

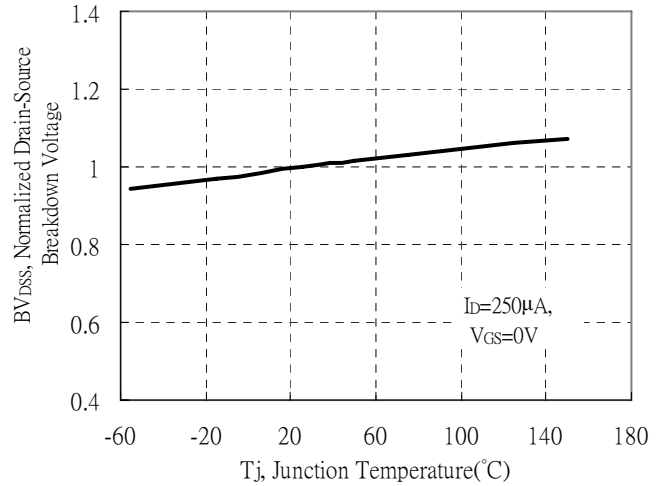

Static Drain-Source On-State resistance vs Drain Current

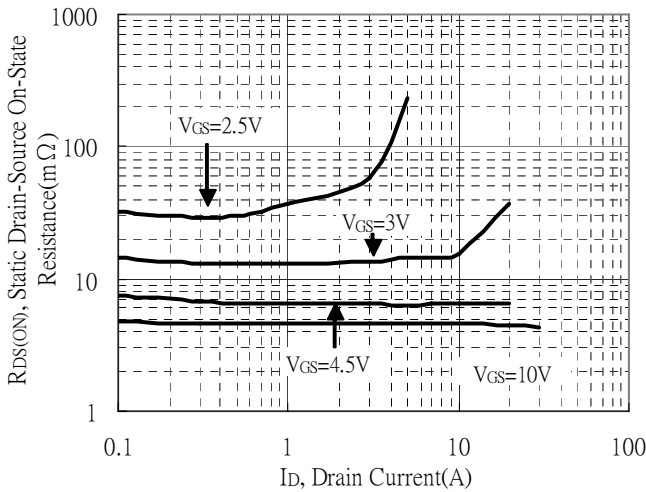

Reverse Drain Current vs Source-Drain Voltage

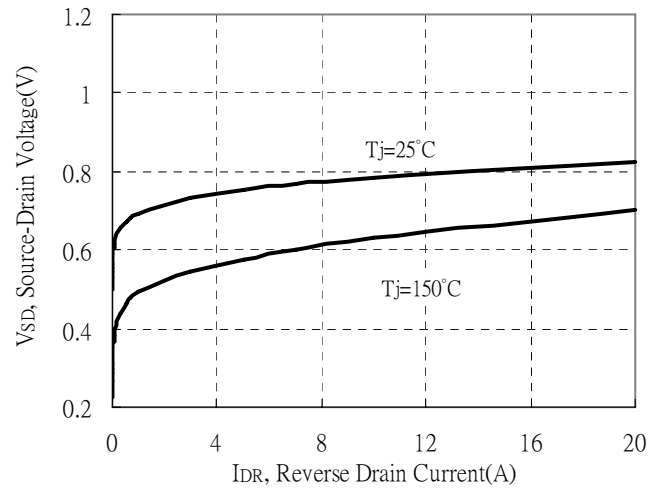

Static Drain-Source On-State Resistance vs Gate-Source Voltage

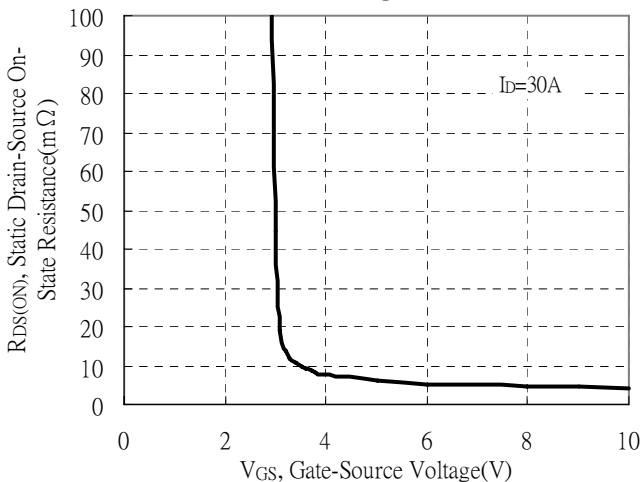

Drain-Source On-State Resistance vs Junction Temperature

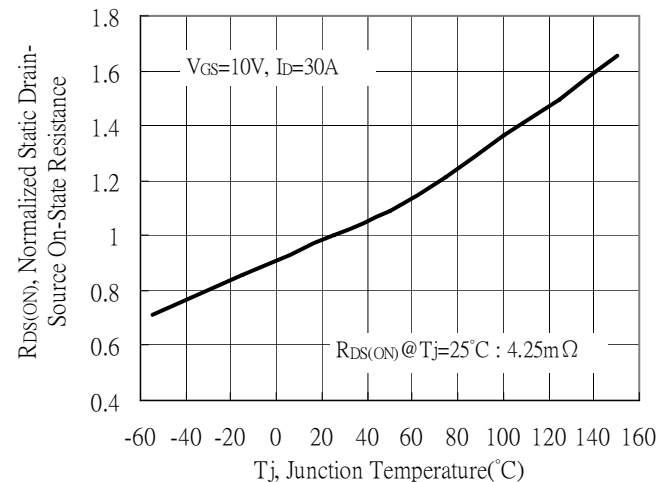

Typical Characteristics(Cont.)

Capacitance vs Drain-to-Source Voltage

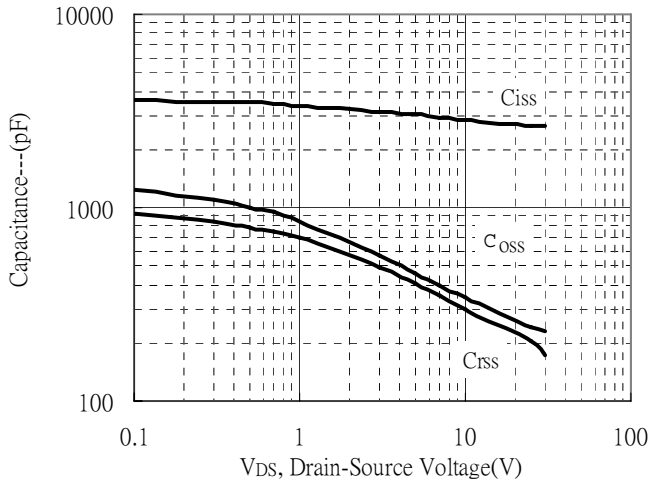

Threshold Voltage vs Junction Temperature

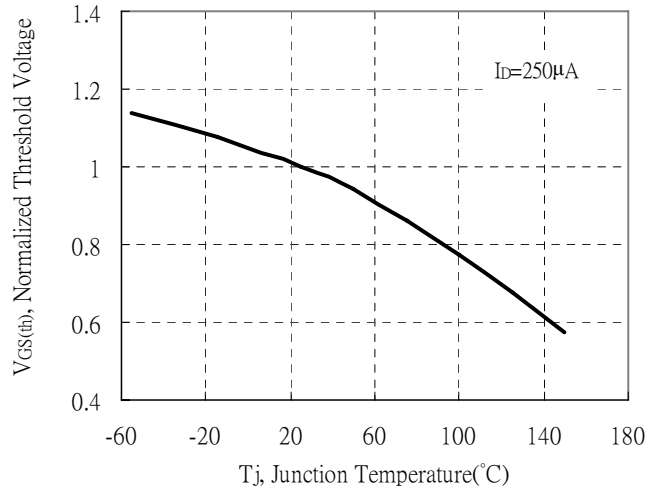

Forward Transfer Admittance vs Drain Current

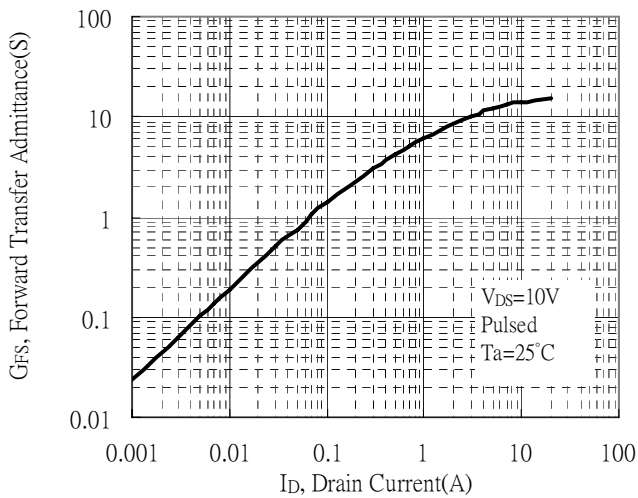

Gate Charge Characteristics

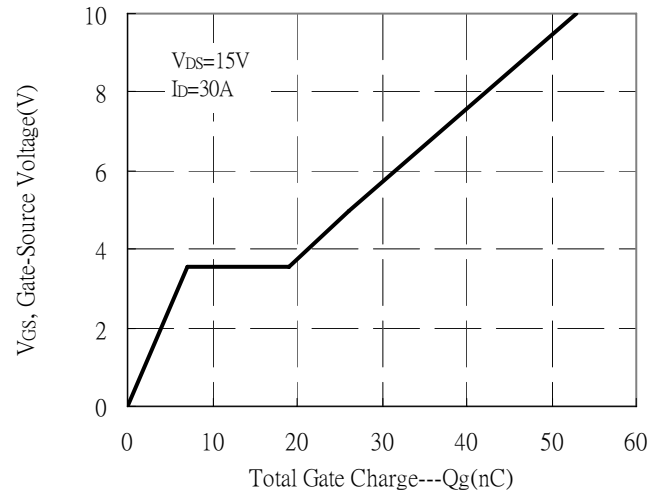

Maximum Safe Operating Area

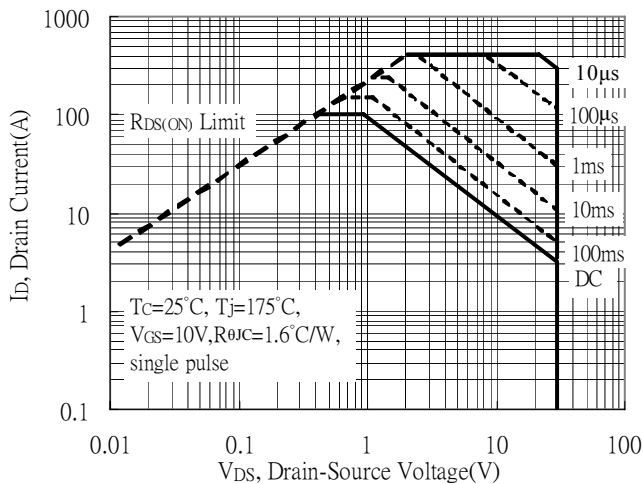

Maximum Drain Current vs Case Temperature

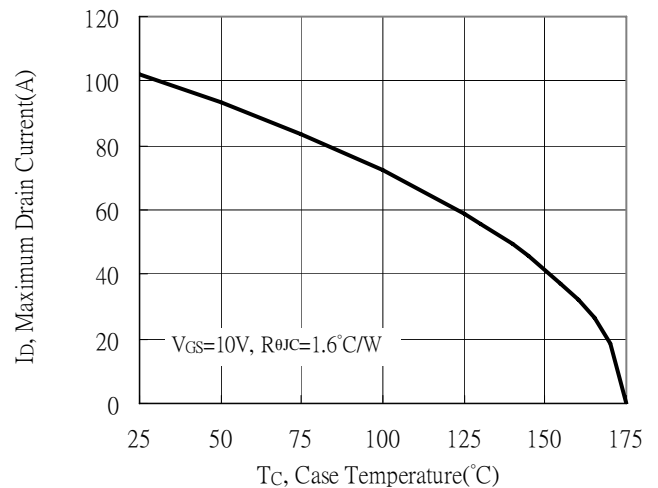



Typical Characteristics(Cont.)

Typical Transfer Characteristics

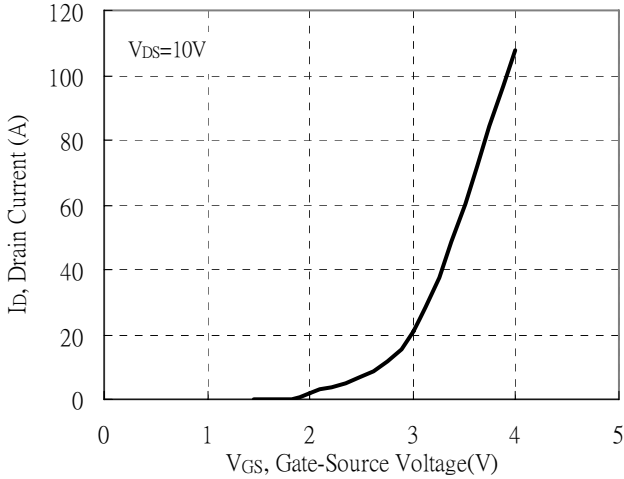

Single Pulse Maximum Power Dissipation

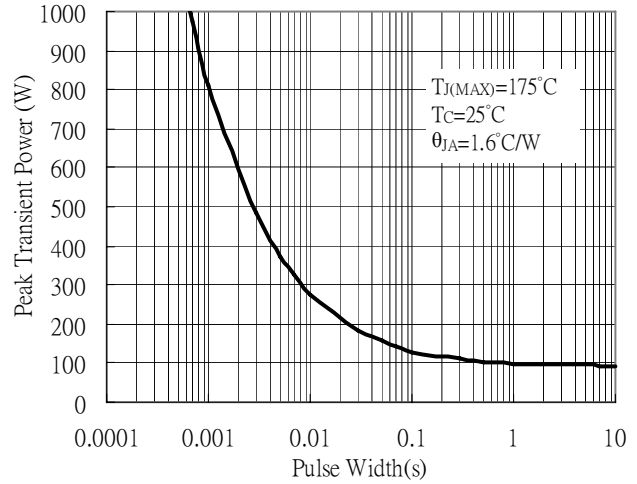

Transient Thermal Response Curves

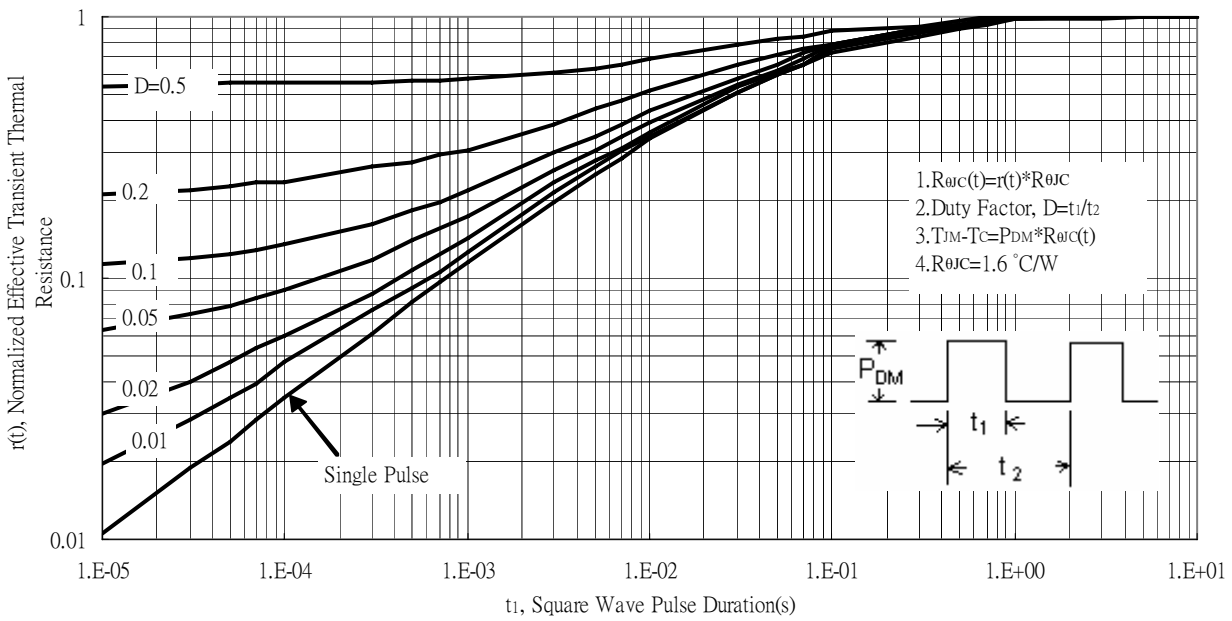

Recommended wave soldering condition

Product	Peak Temperature	Soldering Time
Pb-free devices	260 +0/-5 °C	5 +1/-1 seconds

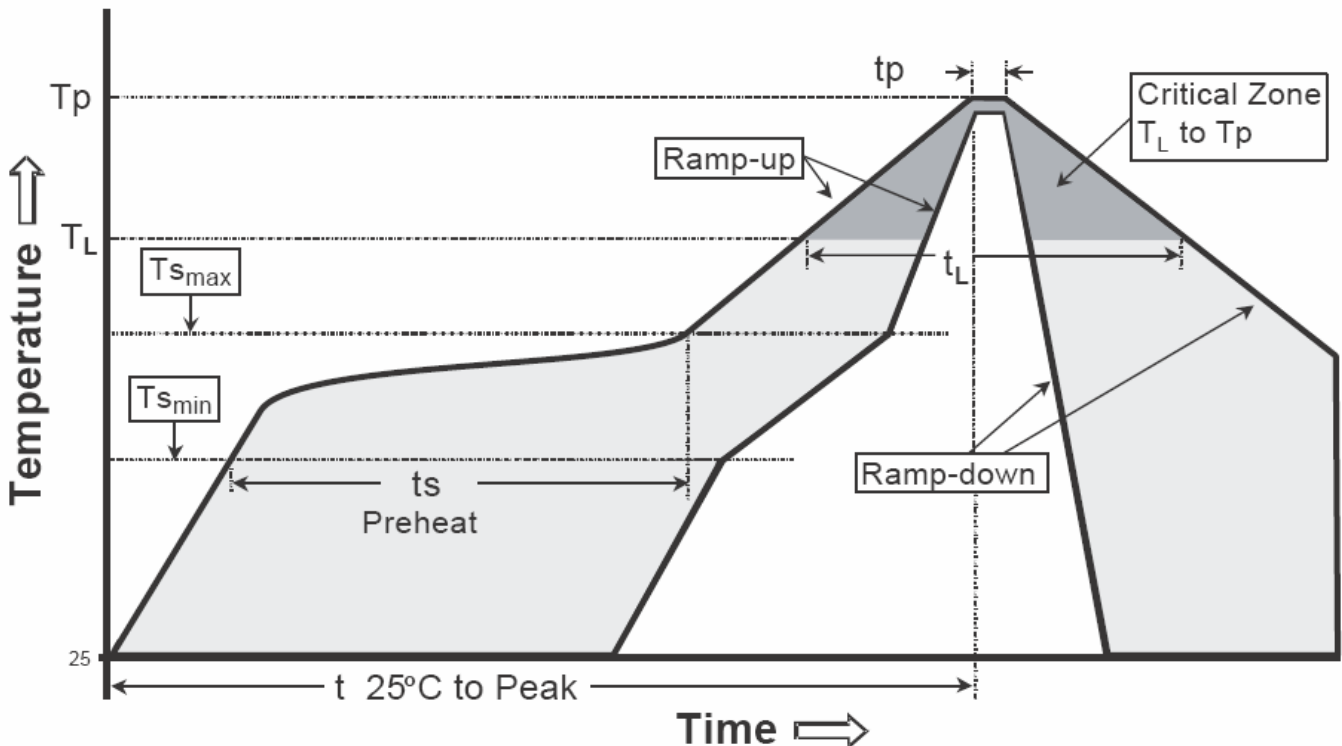
Recommended temperature profile for IR reflow

Profile feature	Sn-Pb eutectic Assembly	Pb-free Assembly
Average ramp-up rate (T _{smax} to T _p)	3°C/second max.	3°C/second max.
Preheat		
-Temperature Min(T _{s min})	100°C	150°C
-Temperature Max(T _{s max})	150°C	200°C
-Time(t _{s min} to t _{s max})	60-120 seconds	60-180 seconds
Time maintained above:		
-Temperature (T _L)	183°C	217°C
- Time (t _L)	60-150 seconds	60-150 seconds
Peak Temperature(T _P)	240 +0/-5 °C	260 +0/-5 °C
Time within 5°C of actual peak temperature(tp)	10-30 seconds	20-40 seconds
Ramp down rate	6°C/second max.	6°C/second max.
Time 25 °C to peak temperature	6 minutes max.	8 minutes max.

Note : All temperatures refer to topside of the package, measured on the package body surface.

TO-220 Dimension

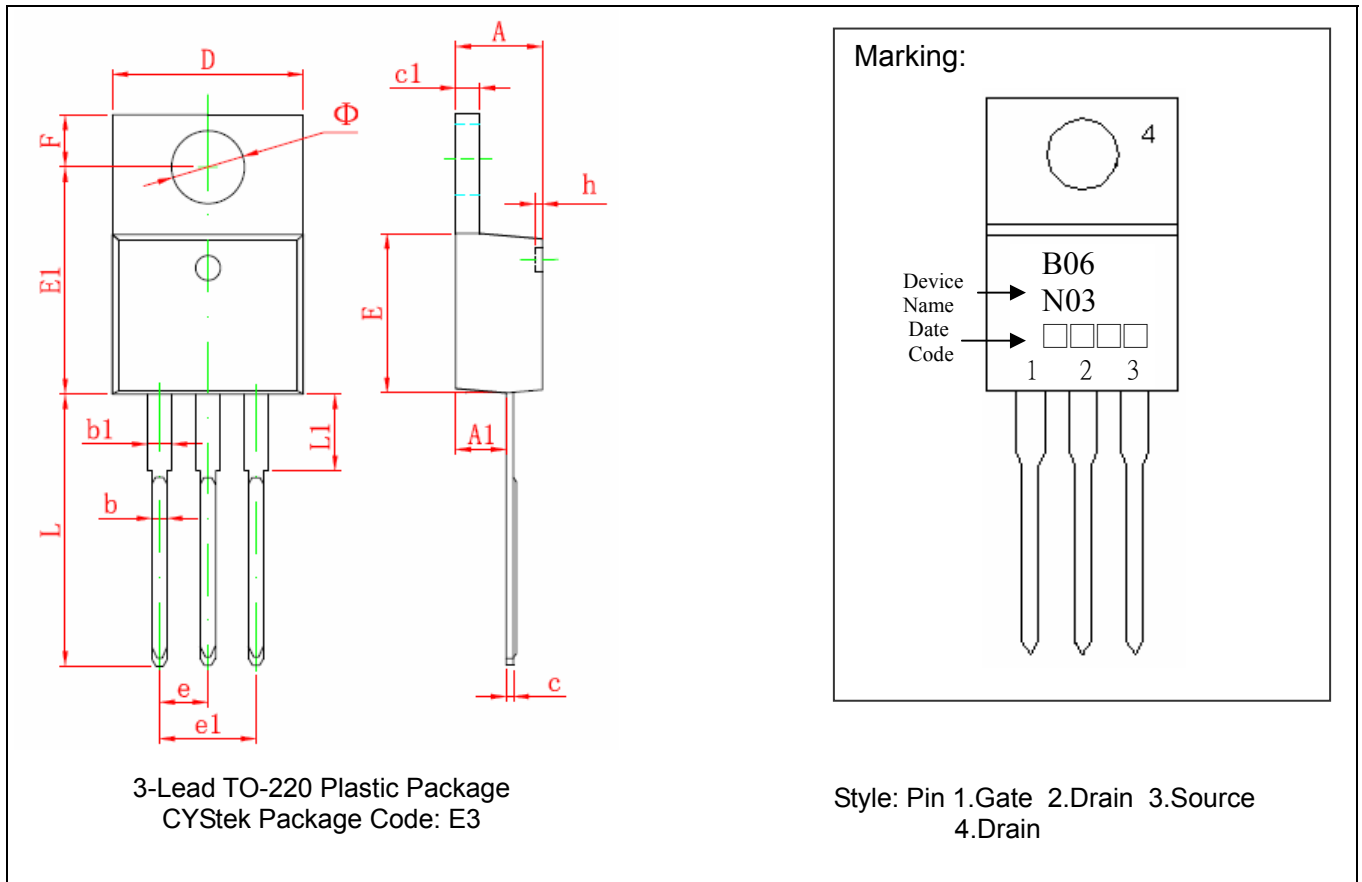

*: Typical

DIM	Millimeters		Inches		DIM	Millimeters		Inches	
	Min.	Max.	Min.	Max.		Min.	Max.	Min.	Max.
A	4.470	4.670	0.176	0.184	E1	12.060	12.460	0.475	0.491
A1	2.520	2.820	0.099	0.111	e	2.540*		0.100*	
b	0.710	0.910	0.028	0.036	e1	4.980	5.180	0.196	0.204
b1	1.170	1.370	0.046	0.054	F	2.590	2.890	0.102	0.114
c	0.310	0.530	0.012	0.021	h	0.000	0.300	0.000	0.012
c1	1.170	1.370	0.046	0.054	L	13.400	13.800	0.528	0.543
D	10.010	10.310	0.394	0.406	L1	3.560	3.960	0.140	0.156
E	8.500	8.900	0.335	0.350	Φ	3.735	3.935	0.147	0.155

Notes: 1.Controlling dimension: millimeters.
 2.Maximum lead thickness includes lead finish thickness, and minimum lead thickness is the minimum thickness of base material.
 3.If there is any question with packing specification or packing method, please contact your local CYStek sales office.

Material:

- Lead: Pure tin plated.
- Mold Compound: Epoxy resin family, flammability solid burning class: UL94V-0.

Important Notice:

- All rights are reserved. Reproduction in whole or in part is prohibited without the prior written approval of CYStek.
- CYStek reserves the right to make changes to its products without notice.
- CYStek **semiconductor products are not warranted to be suitable for use in Life-Support Applications, or systems.**
- CYStek assumes no liability for any consequence of customer product design, infringement of patents, or application assistance.