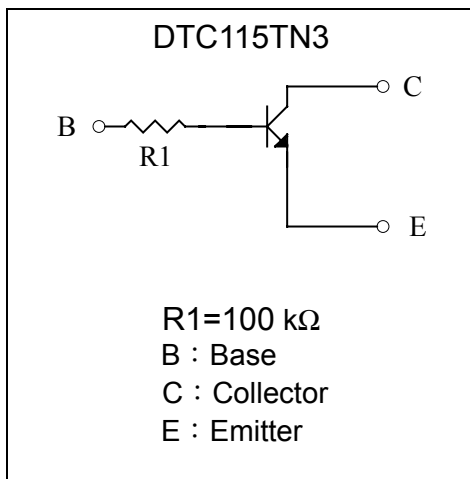
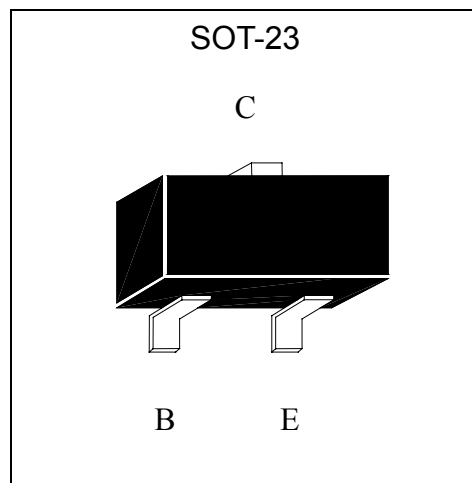

NPN Digital Transistors (Built-in Resistors)

DTC115TN3

Features

- Built-in bias resistors enable the configuration of an inverter circuit without connecting external input resistors (see equivalent circuit).
- The bias resistors consist of thin-film resistors with complete isolation to allow negative biasing of the input. They also have the advantage of almost completely eliminating parasitic effects.
- Only the on/off conditions need to be set for operation, making device design easy.
- Complements the DTA115TN3
- Pb-free package

Equivalent Circuit

Outline

Absolute Maximum Ratings (Ta=25°C)

Parameter	Symbol	Limits	Unit
Collector-Base Voltage	V _{CBO}	50	V
Collector-Emitter Voltage	V _{CEO}	50	V
Emitter-Base Voltage	V _{EBO}	5	V
Collector Current	I _C	100	mA
Power Dissipation	P _d	200	mW
Junction Temperature	T _j	150	°C
Storage Temperature	T _{stg}	-55~+150	°C



Electrical Characteristics (Ta=25°C)

Parameter	Symbol	Min.	Typ.	Max.	Unit	Test Conditions
Collector-Base Breakdown Voltage	V _{CB0}	50	-	-	V	I _C =50μA
Collector-Emitter Breakdown Voltage	V _{CEO}	50	-	-	V	I _C =1mA
Emitter-Base Breakdown Voltage	V _{EB0}	5	-	-	V	I _E =50μA
Collector-Base Cutoff Current	I _{CB0}	-	-	0.5	μA	V _{CB} =50V
Emitter-Base Cutoff Current	I _{EB0}	-	-	0.5	μA	V _{EB} =4V
Collector-Emitter Saturation Voltage	V _{CE(sat)}	-	-	0.3	V	I _C =1mA, I _B =0.1mA
DC Current Gain	h _{FE}	100	-	600	-	V _{CE} =5V, I _C =1mA
Input Resistance	R	70	100	130	kΩ	-
Transition Frequency	f _T	-	250	-	MHz	V _{CE} =10V, I _C =5mA, f=100MHz *

* Transition frequency of the device

Ordering Information

Device	Package	Shipping	Marking
DTC115TN3	SOT-23 (Pb-free)	3000 pcs / Tape & Reel	8U



Characteristic Curves

Current Gain vs Collector Current

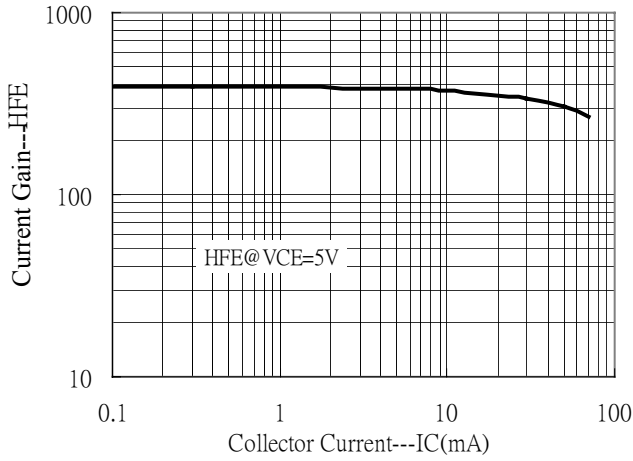

Saturation Voltage vs Collector Current

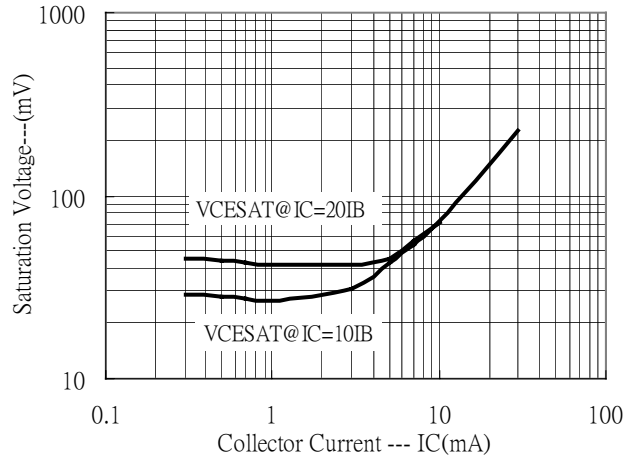

Power Derating Curve

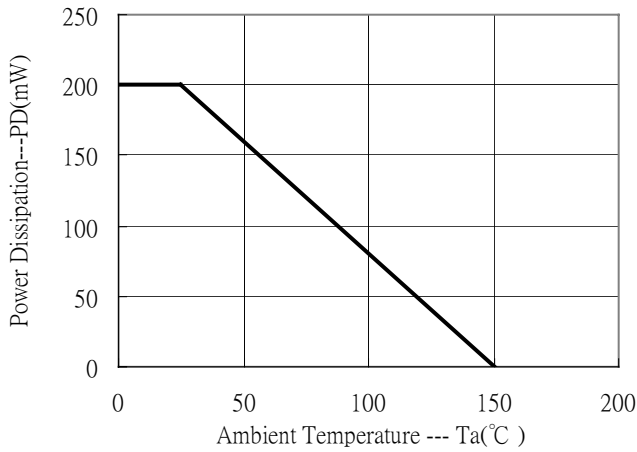

SOT-23 Dimension

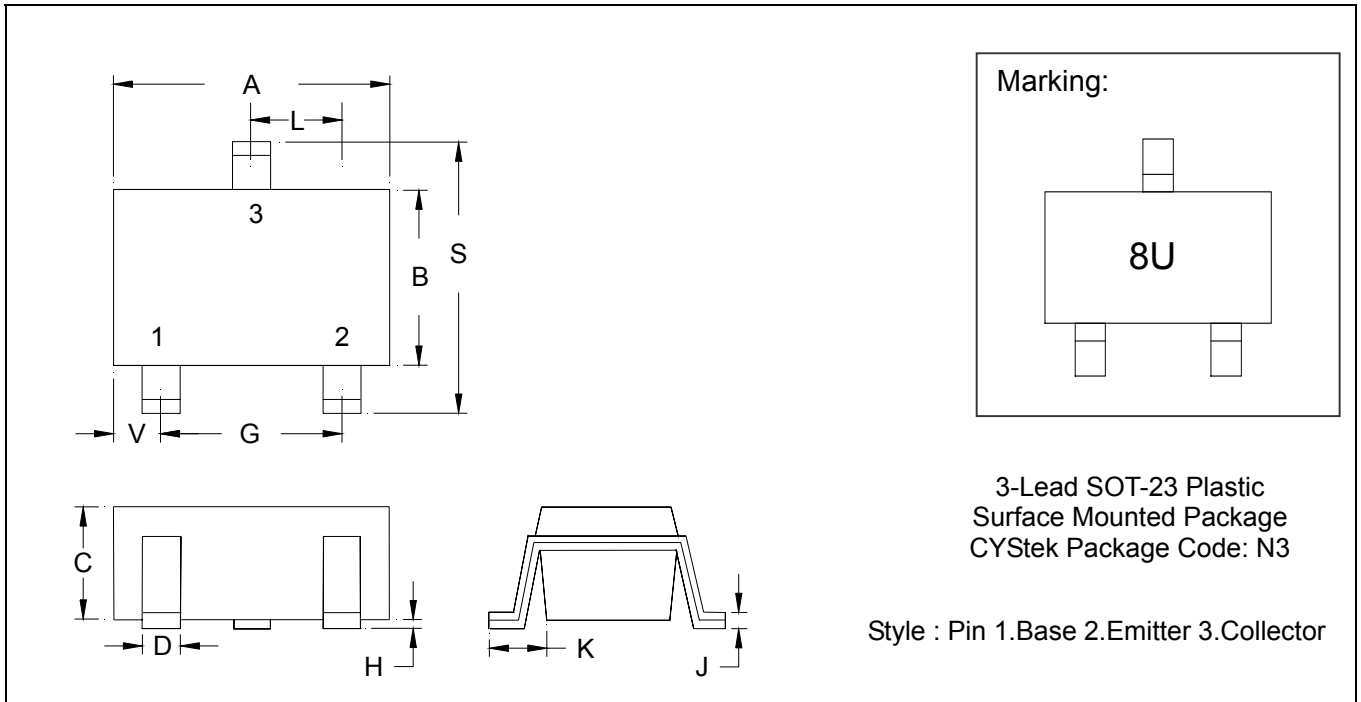

*:Typical

DIM	Inches		Millimeters		DIM	Inches		Millimeters	
	Min.	Max.	Min.	Max.		Min.	Max.	Min.	Max.
A	0.1102	0.1204	2.80	3.04	J	0.0034	0.0070	0.085	0.177
B	0.0472	0.0630	1.20	1.60	K	0.0128	0.0266	0.32	0.67
C	0.0335	0.0512	0.89	1.30	L	0.0335	0.0453	0.85	1.15
D	0.0118	0.0197	0.30	0.50	S	0.0830	0.1083	2.10	2.75
G	0.0669	0.0910	1.70	2.30	V	0.0098	0.0256	0.25	0.65
H	0.0005	0.0040	0.013	0.10					

- Notes :**
- 1.Controlling dimension : millimeters.
 - 2.Maximum lead thickness includes lead finish thickness, and minimum lead thickness is the minimum thickness of base material.
 - 3.If there is any question with packing specification or packing method, please contact your local CYStek sales office.

Material :

- Lead : 42 Alloy ; solder plating
- Mold Compound : Epoxy resin family, flammability solid burning class:UL94V-0

Important Notice:

- All rights are reserved. Reproduction in whole or in part is prohibited without the prior written approval of CYStek.
- CYStek reserves the right to make changes to its products without notice.
- CYStek **semiconductor products are not warranted to be suitable for use in Life-Support Applications, or systems.**
- CYStek assumes no liability for any consequence of customer product design, infringement of patents, or application assistance.