

NPN Digital Transistors (Built-in Resistors)

DTC144WN3S

Features

- Built-in bias resistors enable the configuration of an inverter circuit without connecting external input resistors (see equivalent circuit).
- The bias resistors consist of thin-film resistors with complete isolation to allow negative biasing of the input. They also have the advantage of almost completely eliminating parasitic effects.
- Only the on/off conditions need to be set for operation, making device design easy.
- Complements the DTA144WN3S
- Pb-free package

Equivalent Circuit

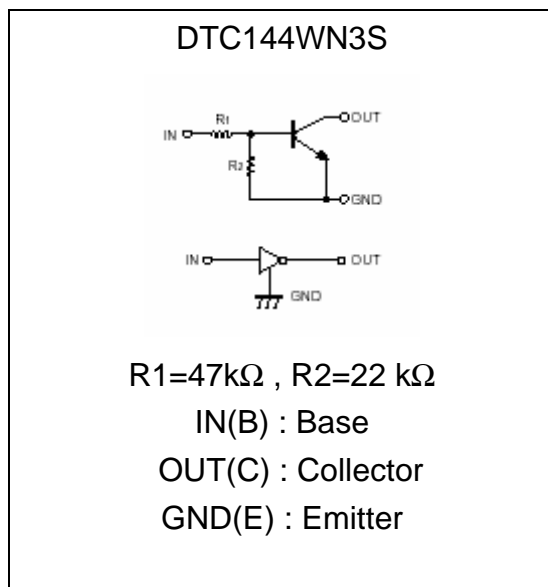

Outline

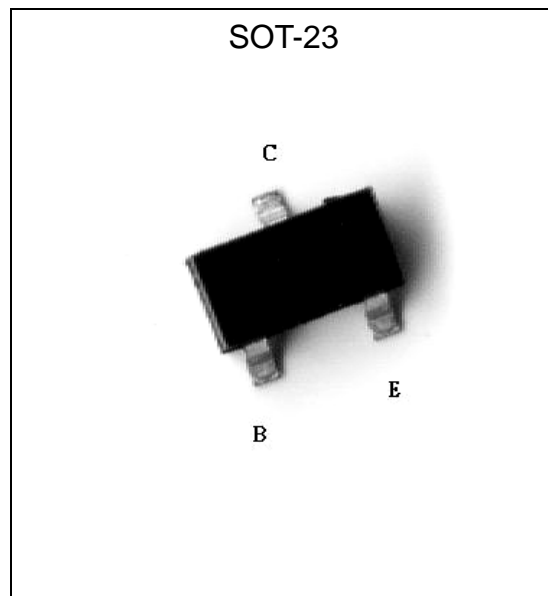

**Absolute Maximum Ratings (Ta=25°C)**

Parameter	Symbol	Limits	Unit
Supply Voltage	V _{CC}	50	V
Input Voltage	V _I	-10~+40	V
Output Current	I _O	30	mA
	I _{O(max.)}	100	mA
Power Dissipation @ T _A =25°C	P _D	200	mW
Power Dissipation @ T _C =25°C		1.35	W
Thermal Resistance, Junction to Ambient	R _{θJA}	625	°C/W
Thermal Resistance, Junction to Case	R _{θJC}	92.6	
Junction Temperature	T _J	150	°C
Storage Temperature	T _{stg}	-55~+150	°C

Electrical Characteristics (Ta=25°C)

Parameter	Symbol	Min.	Typ.	Max.	Unit	Test Conditions
Input Voltage	V _{I(off)}	-	-	0.8	V	V _{CC} =5V, I _O =100μA
	V _{I(on)}	4	-	-	V	V _O =0.3V, I _O =2mA
Output Voltage	V _{O(on)}	-	-	0.3	V	I _O =10mA, I _I =0.5mA
Input Current	I _I	-	-	0.16	mA	V _I =5V
Output Current	I _{O(off)}	-	-	0.5	μA	V _{CC} =50V, V _I =0V
DC Current Gain	G _I	56	-	-	-	V _O =5V, I _O =5mA
Input Resistance	R _I	32.9	47	61.1	kΩ	-
Resistance Ratio	R ₂ /R ₁	0.37	0.47	0.57	-	-
Transition Frequency	f _T	-	250	-	MHz	V _{CE} =10V, I _C =5mA, f=100MHz *

* Transition frequency of the device

Ordering Information

Device	Package	Shipping	Marking
DTC144WN3S	SOT-23 (Pb-free)	3000 pcs / tape & reel	8P



Characteristic Curves

Current Gain vs Output Current

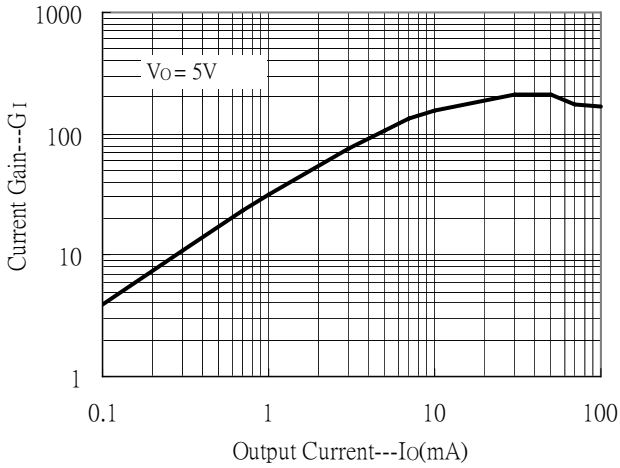

Output Voltage vs Output Current

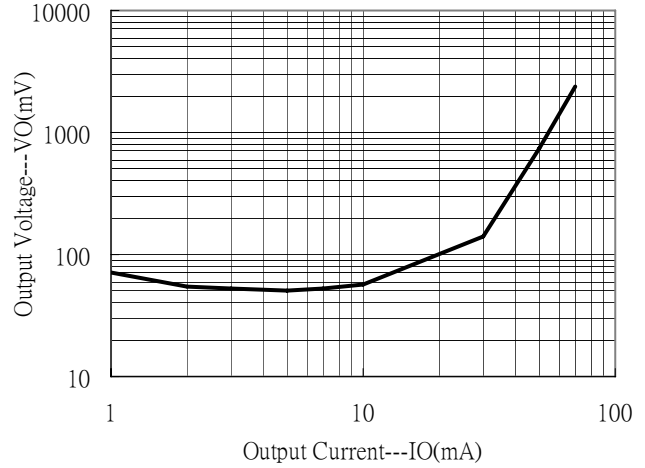

Input Voltage vs Output Current(ON characteristics)

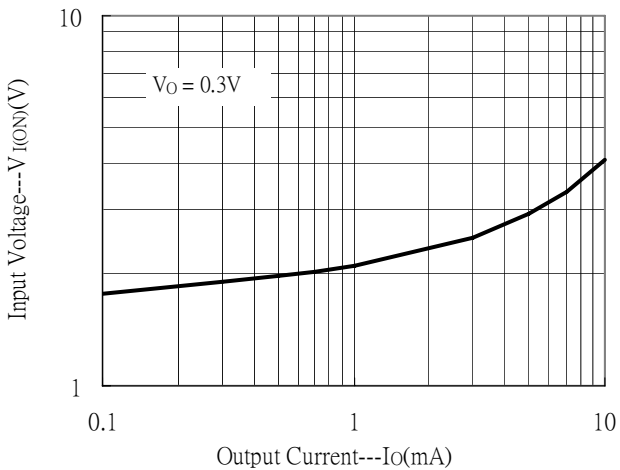

Output Current vs Input Voltage(OFF characteristics)

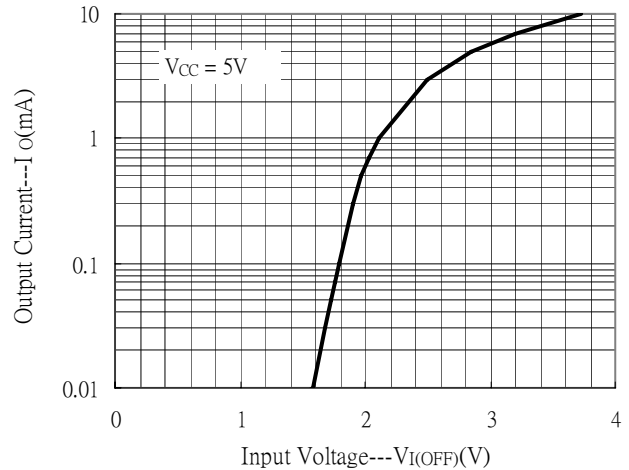

Power Derating Curve

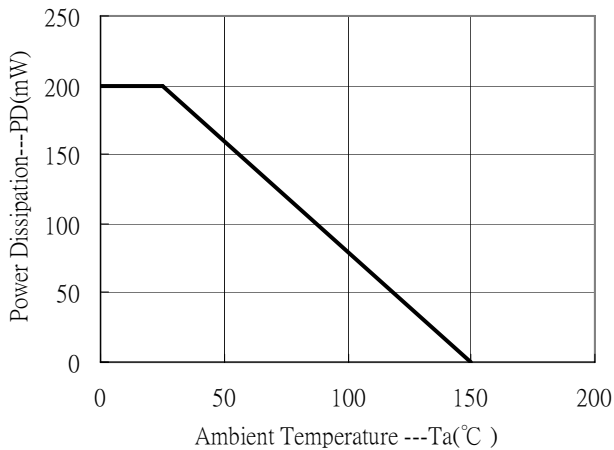



Recommended IR reflow temperature profile

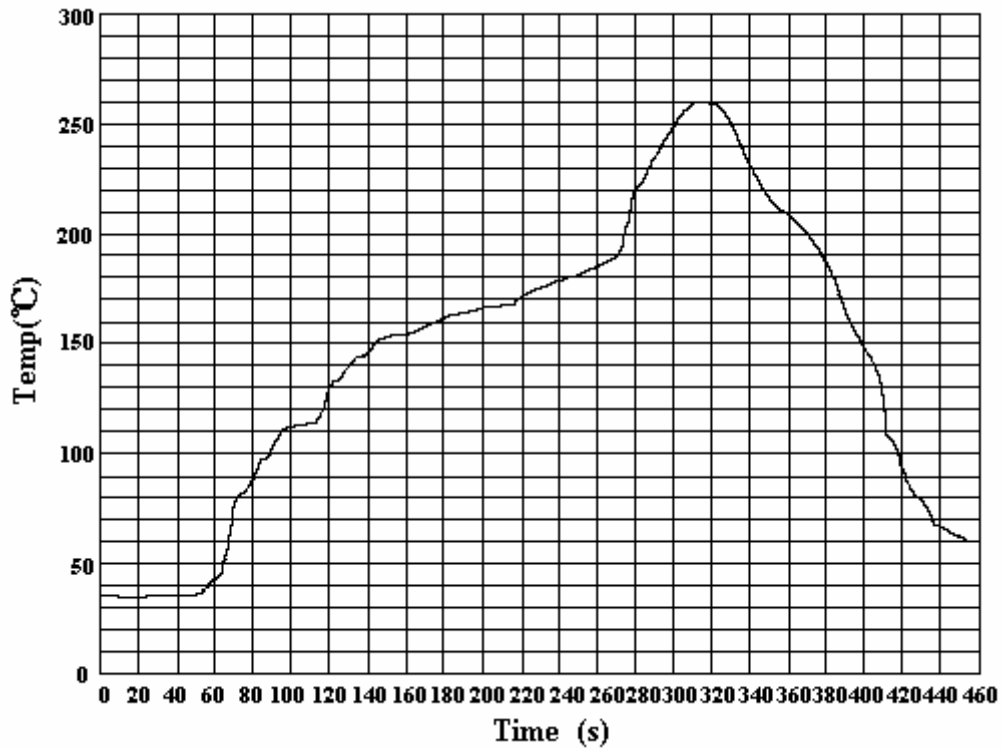

Average ramp-up rate(25 to 150°C)	1~4 °C/second
Preheat temperature 150~180°C	60~90 seconds
Temperature maintained above 220°C	30 seconds min.
Time within 5°C of actual peak temperature	3~5 seconds
Peak temperature range	255+0/-5°C
Ramp-down rate	2~10 °C/second
Time 25°C to peak temperature	6 minutes max.

SOT-23 Dimension

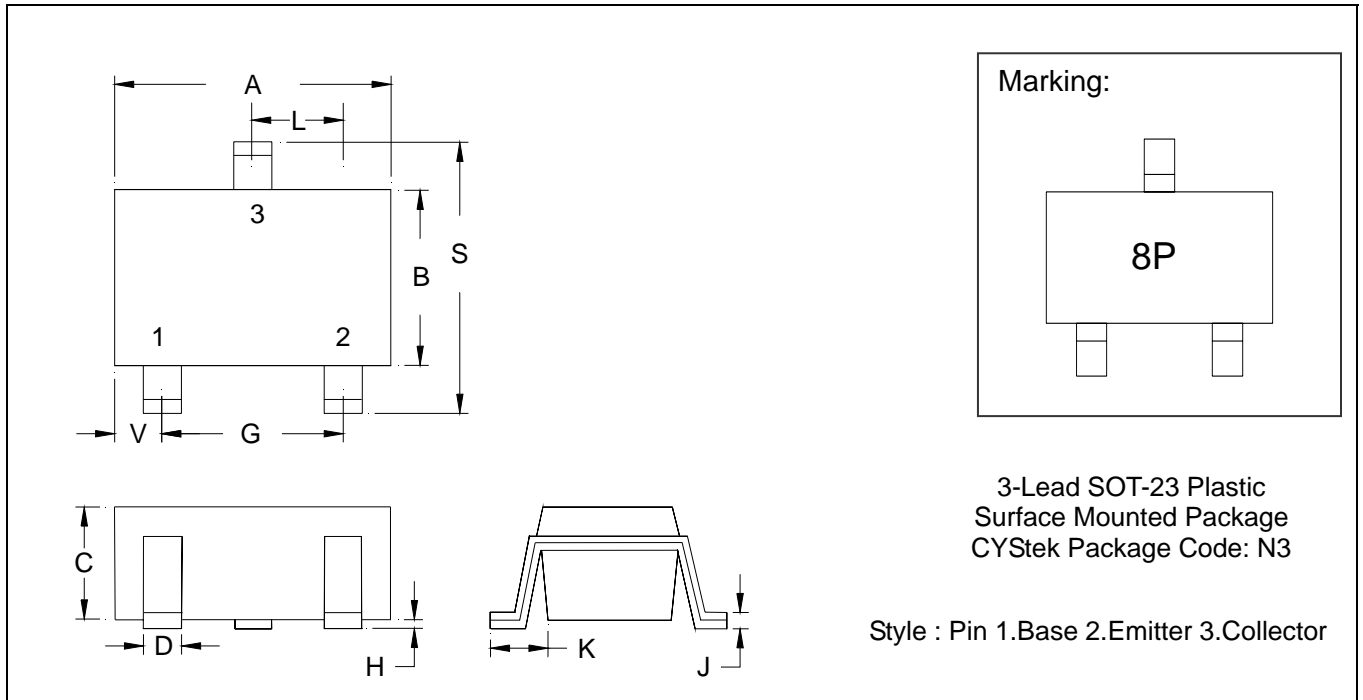

*:Typical

DIM	Inches		Millimeters		DIM	Inches		Millimeters	
	Min.	Max.	Min.	Max.		Min.	Max.	Min.	Max.
A	0.1102	0.1204	2.80	3.04	J	0.0034	0.0070	0.085	0.177
B	0.0472	0.0630	1.20	1.60	K	0.0128	0.0266	0.32	0.67
C	0.0335	0.0512	0.89	1.30	L	0.0335	0.0453	0.85	1.15
D	0.0118	0.0197	0.30	0.50	S	0.0830	0.1083	2.10	2.75
G	0.0669	0.0910	1.70	2.30	V	0.0098	0.0256	0.25	0.65
H	0.0005	0.0040	0.013	0.10					

- Notes : 1.Controlling dimension : millimeters.
 2.Maximum lead thickness includes lead finish thickness, and minimum lead thickness is the minimum thickness of base material.
 3.If there is any question with packing specification or packing method, please contact your local CYStek sales office.

Material :

- Lead : 42 Alloy ; pure tin plated
- Mold Compound : Epoxy resin family, flammability solid burning class:UL94V-0

Important Notice:

- All rights are reserved. Reproduction in whole or in part is prohibited without the prior written approval of CYStek.
- CYStek reserves the right to make changes to its products without notice.
- CYStek **semiconductor products are not warranted to be suitable for use in Life-Support Applications, or systems.**
- CYStek assumes no liability for any consequence of customer product design, infringement of patents, or application assistance.