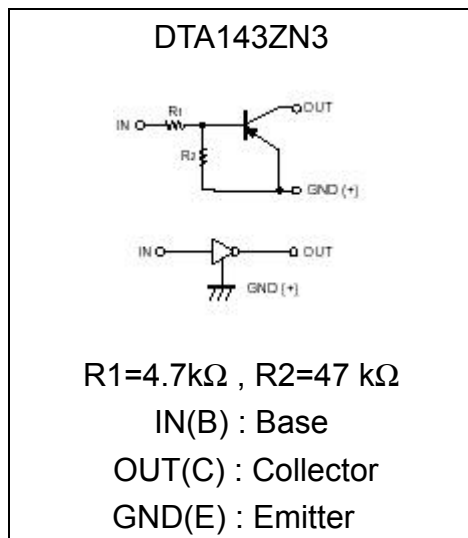
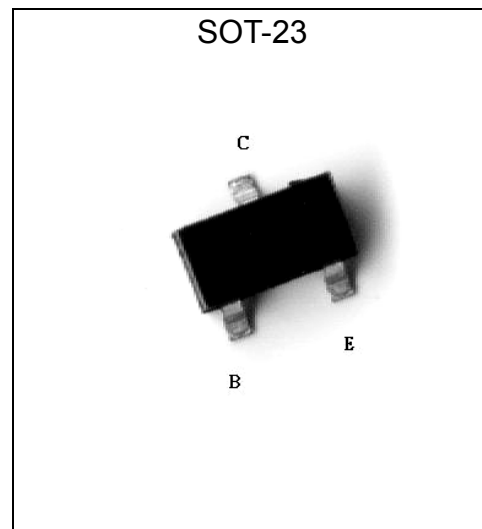

**PNP Digital Transistors (Built-in Resistors)**

# DTA143ZN3

**Features**

- Built-in bias resistors enable the configuration of an inverter circuit without connecting external input resistors (see equivalent circuit).
- The bias resistors consist of thin-film resistors with complete isolation to allow positive biasing of the input. They also have the advantage of almost completely eliminating parasitic effects.
- Only the on/off conditions need to be set for operation, making device design easy.
- Complements the DTC143ZN3
- Pb-free package

**Equivalent Circuit**

**Outline**

**Absolute Maximum Ratings (Ta=25°C)**

Parameter	Symbol	Limits	Unit
Supply Voltage	V <sub>CC</sub>	-50	V
Input Voltage	V <sub>IN</sub>	-30~+5	V
Output Current	I <sub>O</sub>	-100	mA
	I <sub>O(max.)</sub>	-100	mA
Power Dissipation	P <sub>d</sub>	200	mW
Junction Temperature	T <sub>j</sub>	150	°C
Storage Temperature	T <sub>stg</sub>	-55~+150	°C

**Electrical Characteristics (Ta=25°C)**

Parameter	Symbol	Min.	Typ.	Max.	Unit	Test Conditions
Input Voltage	V <sub>I(off)</sub>	-	-	-0.5	V	V <sub>CC</sub> =-5V, I <sub>o</sub> =-100μA
	V <sub>I(on)</sub>	-1.3	-	-	V	V <sub>O</sub> =-0.3V, I <sub>o</sub> =-5mA
Output Voltage	V <sub>O(on)</sub>	-	-0.1	-0.3	V	I <sub>o</sub> /I <sub>i</sub> =-5mA/-0.25mA
Input Current	I <sub>i</sub>	-	-	-1.8	mA	V <sub>i</sub> =-5V
Output Current	I <sub>O(off)</sub>	-	-	-0.5	μA	V <sub>CC</sub> =-50V, V <sub>i</sub> =0V
DC Current Gain	G <sub>i</sub>	80	-	-	-	V <sub>o</sub> =-5V, I <sub>o</sub> =-10mA
Input Resistance	R <sub>1</sub>	3.29	4.7	6.11	kΩ	-
Resistance Ratio	R <sub>2</sub> /R <sub>1</sub>	8	10	12	-	-
Transition Frequency	f <sub>T</sub>	-	250	-	MHz	V <sub>CE</sub> =-10V, I <sub>c</sub> =-5mA, f=100MHz*

\* Transition frequency of the device

**Ordering Information**

Device	Package	Shipping	Marking
DTA143ZN3	SOT-23 (Pb-free)	3000 pcs / Tape & Reel	6K



### Product Designation

**DT**   **X**   **X**   **X**   **X**   **X**   **XX**  
 (1)   (2)   (3)   (4)   (5)   (6)   (7)

(1) Indicates that transistor is digital

(2) Indicates polarity

- A, B . . . . PNP
- C, D . . . . NPN

(3) Indicates device specification

(4) Indicates the basis of the R<sub>1</sub> resistance value

- 1 . . . . 1.0
- 2 . . . . 2.2
- 3 . . . . 3.3
- 4 . . . . 4.7
- 6 . . . . 6.8

(5) Indicates power-of-ten of R<sub>1</sub> value

- 3 . . . . 10<sup>3</sup>
- 4 . . . . 10<sup>4</sup>

The value of R<sub>1</sub> is indicates by combining (4) and (5)

- 24 . . . . 2.2×10<sup>4</sup> =22kΩ
- 43 . . . . 4.7×10<sup>3</sup> =22kΩ

(6) Indicates resistance ratio R<sub>1</sub>/R<sub>2</sub>

- E . . . . R<sub>1</sub>/R<sub>2</sub>=1/1
- X . . . . R<sub>1</sub>/R<sub>2</sub>=2/1
- Y . . . . R<sub>1</sub>/R<sub>2</sub>=5/1
- Z . . . . R<sub>1</sub>/R<sub>2</sub>=10/1
- J . . . . R<sub>1</sub>/R<sub>2</sub>=20/1
- W . . . . R<sub>1</sub>/R<sub>2</sub>=1/2
- U . . . . R<sub>1</sub>/R<sub>2</sub>=1/5
- V . . . . R<sub>1</sub>/R<sub>2</sub>=1/10
- T . . . . R<sub>1</sub> only
- G . . . . T<sub>2</sub> only

(7) Indicates package shape

- N3 . . . . SOT-23
- A3 . . . . TO-92

**Reel Dimension**

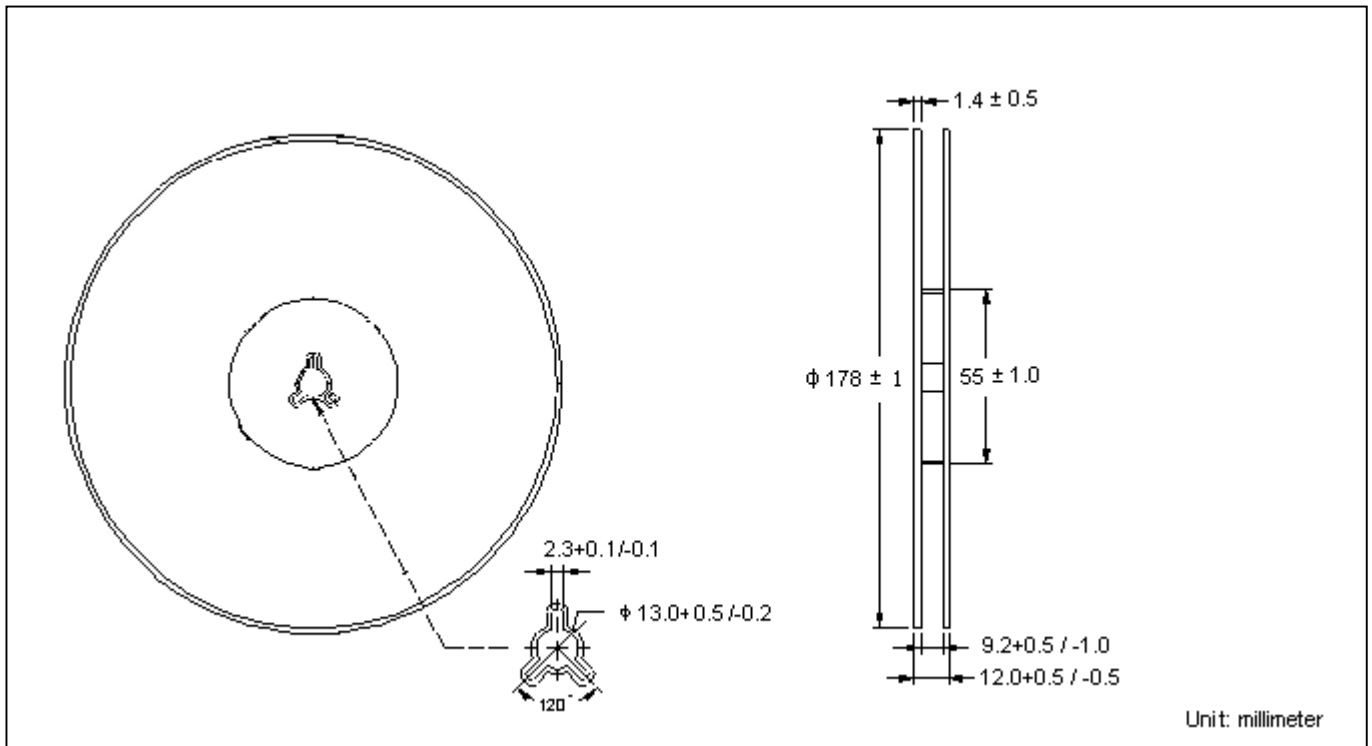

**Carrier Tape Dimension**

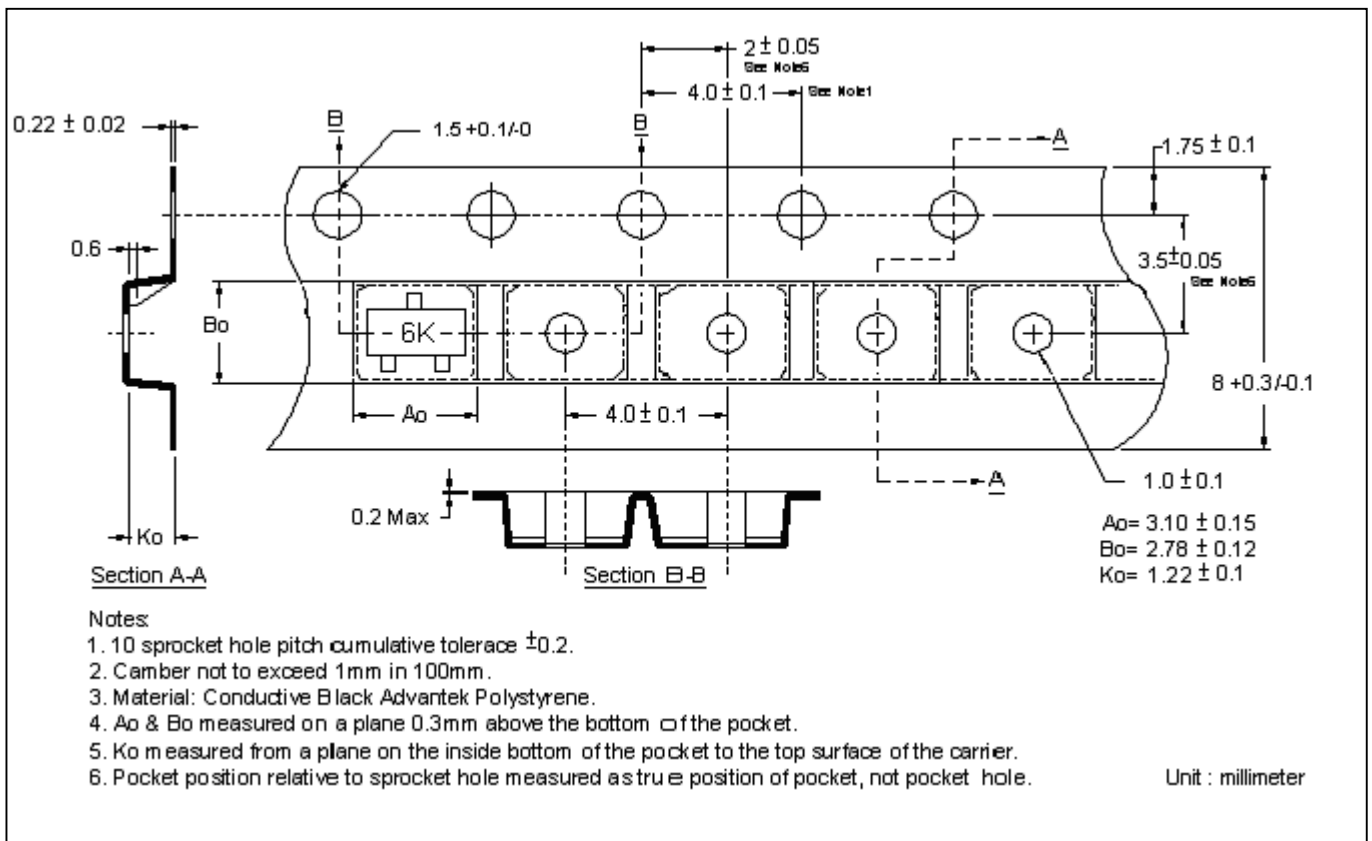

**Recommended IR reflow profile**

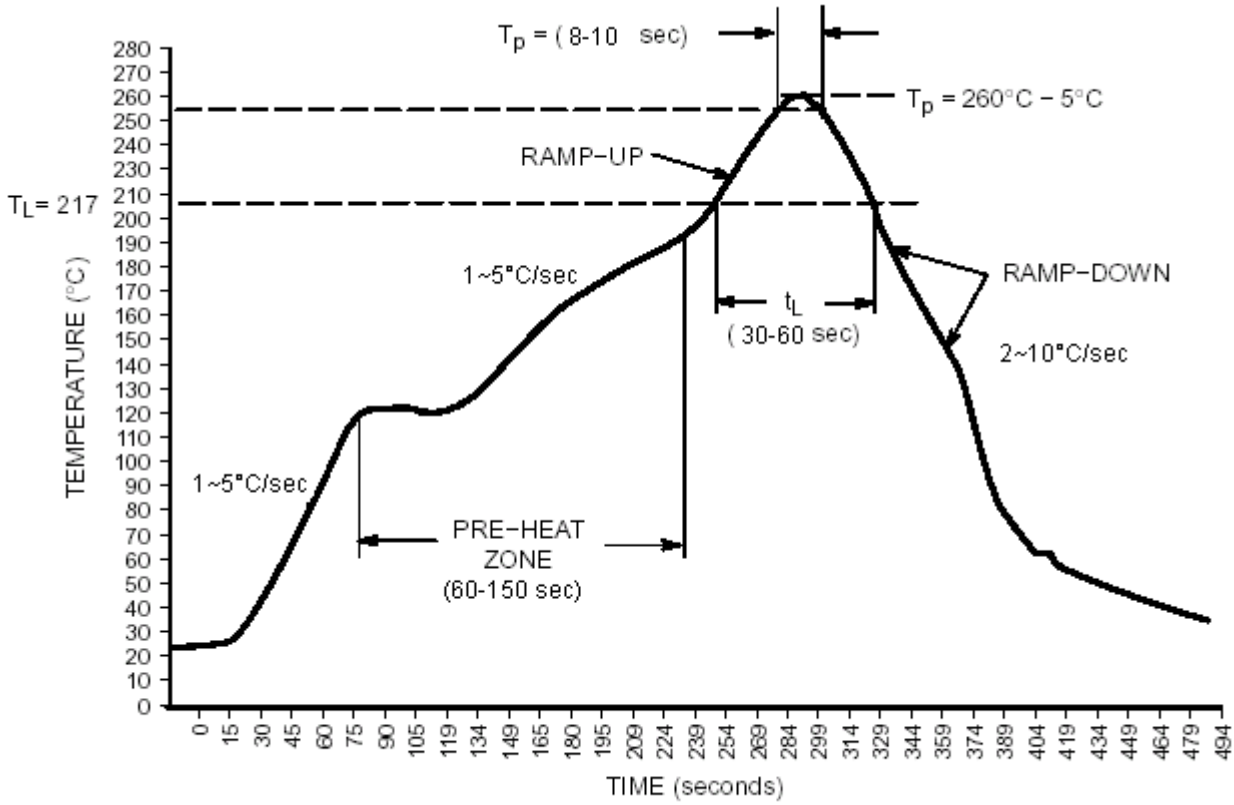

**SOT-23 Dimension**

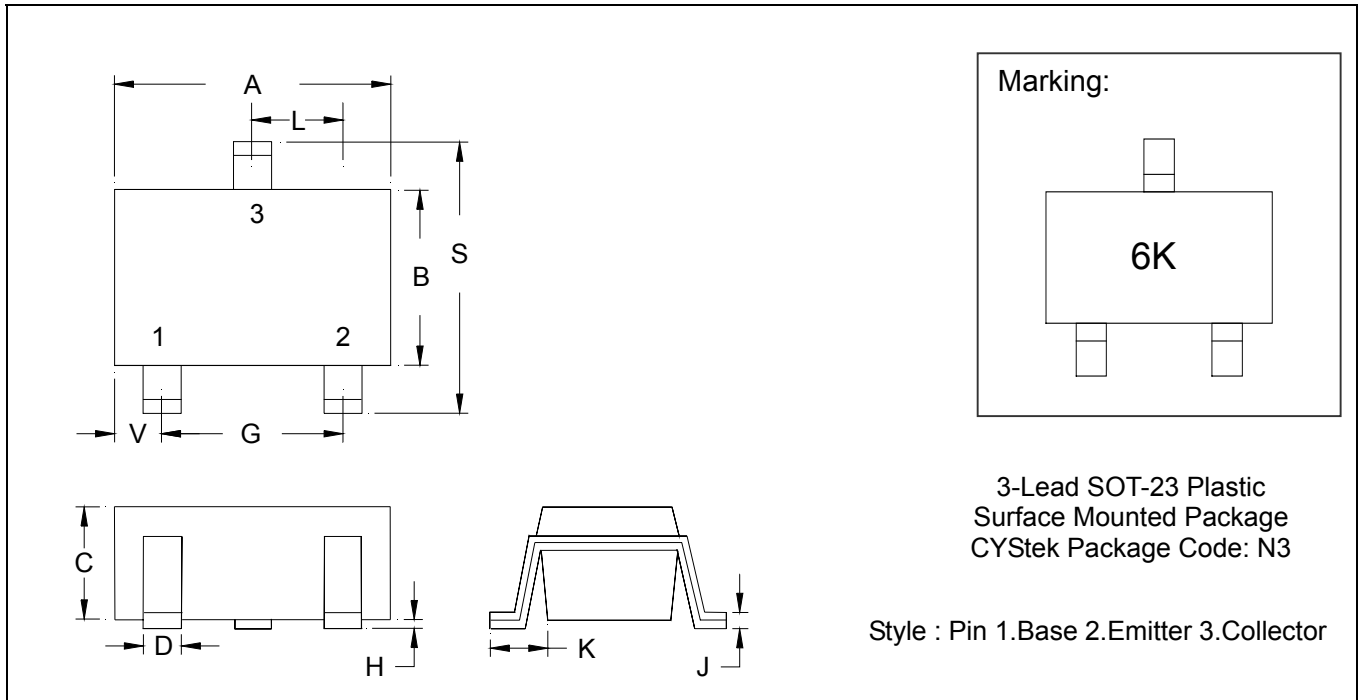

\*:Typical

DIM	Inches		Millimeters		DIM	Inches		Millimeters	
	Min.	Max.	Min.	Max.		Min.	Max.	Min.	Max.
A	0.1102	0.1204	2.80	3.04	J	0.0034	0.0070	0.085	0.177
B	0.0472	0.0630	1.20	1.60	K	0.0128	0.0266	0.32	0.67
C	0.0335	0.0512	0.89	1.30	L	0.0335	0.0453	0.85	1.15
D	0.0118	0.0197	0.30	0.50	S	0.0830	0.1083	2.10	2.75
G	0.0669	0.0910	1.70	2.30	V	0.0098	0.0256	0.25	0.65
H	0.0005	0.0040	0.013	0.10					

- Notes : 1.Controlling dimension : millimeters.  
 2.Maximum lead thickness includes lead finish thickness, and minimum lead thickness is the minimum thickness of base material.  
 3.If there is any question with packing specification or packing method, please contact your local CYStek sales office.

**Material :**

- Lead : 42 Alloy ; solder plating
- Mold Compound : Epoxy resin family, flammability solid burning class:UL94V-0

**Important Notice:**

- All rights are reserved. Reproduction in whole or in part is prohibited without the prior written approval of CYStek.
- CYStek reserves the right to make changes to its products without notice.
- CYStek **semiconductor products are not warranted to be suitable for use in Life-Support Applications, or systems.**
- CYStek assumes no liability for any consequence of customer product design, infringement of patents, or application assistance.