

## General Purpose NPN Digital Transistors (Built-in Resistors)

# DTC143TS3

### Features

- Built-in bias resistors enable the configuration of an inverter circuit without connecting external input resistors (see equivalent circuit).
- The bias resistors consist of thin-film resistors with complete isolation to allow negative biasing of the input. They also have the advantage of almost completely eliminating parasitic effects.
- Only the on/off conditions need to be set for operation, making device design easy.
- Complements the DTA143TS3

### Equivalent Circuit

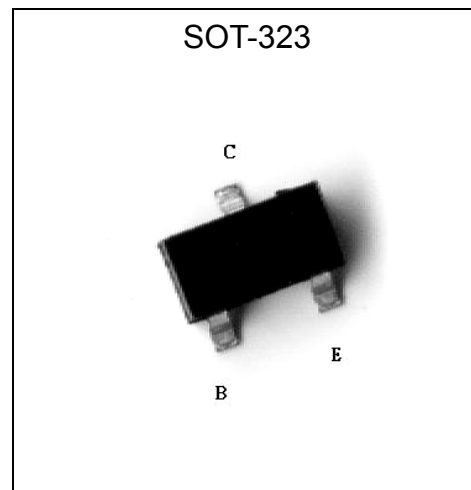
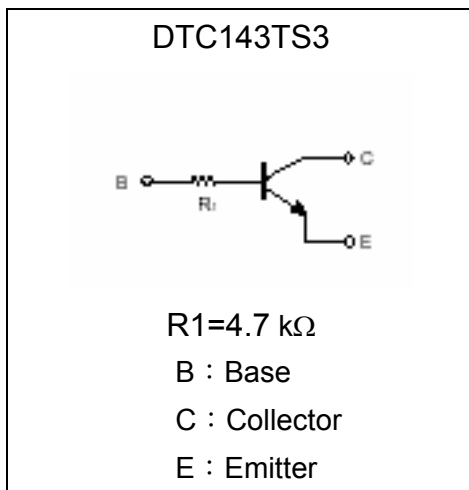

### Absolute Maximum Ratings (Ta=25°C)

Parameter	Symbol	Limits	Unit
Collector-Base Voltage	VCBO	50	V
Collector-Emitter Voltage	VCEO	50	V
Emitter-Base Voltage	VEBO	5	V
Collector Current	IC	100	mA
Power Dissipation	Pd	200	mW
Junction Temperature	Tj	150	°C
Storage Temperature	Tstg	-55~+150	°C



**Electrical Characteristics** (Ta=25°C)

Parameter	Symbol	Min.	Typ.	Max.	Unit	Test Conditions
Collector-Base Breakdown Voltage	VCBO	50	-	-	V	IC=50uA
Collector-Emitter Breakdown Voltage	VCEO	50	-	-	V	IC=1mA
Emitter-Base Breakdown Voltage	VEBO	5	-	-	V	IE=50uA
Collector-Base Cutoff Current	ICBO	-	-	0.5	uA	VCB=50V
Emitter-Base Cutoff Current	IEBO	-	-	0.5	uA	VEB=4V
Collector-Emitter Saturation Voltage	VCE(sat)	-	-	0.3	V	IC=5mA, IB=0.25mA
DC Current Gain	hFE	100	-	600	-	VCE=5V, IC=1mA
Input Resistance	R	3.29	4.7	6.11	kΩ	-
Transition Frequency	fT	-	250	-	MHz	VCE=10V, IE=5mA, f=100MHz*

\* Transition frequency of the device

**Characteristic Curves**

Current Gain vs Collector Current

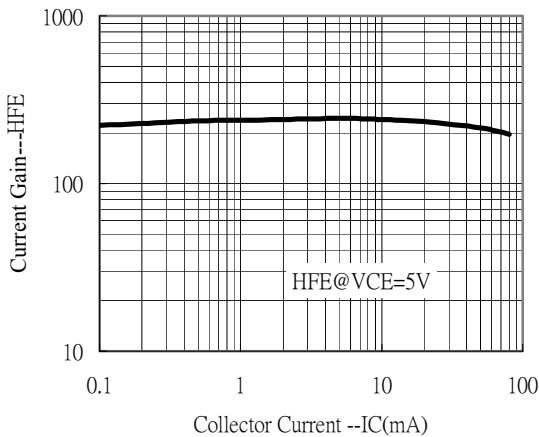

Saturation Voltage vs Collector Current

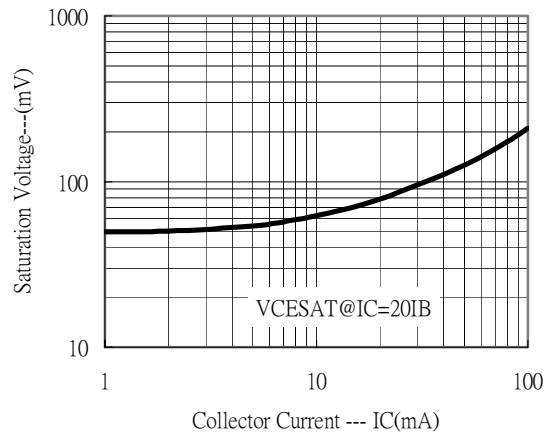

PD - Ta

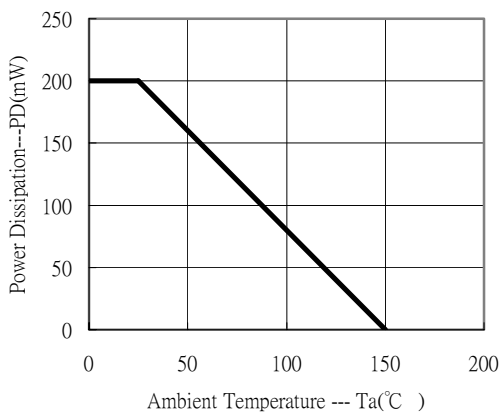

**SOT-323 Dimension**

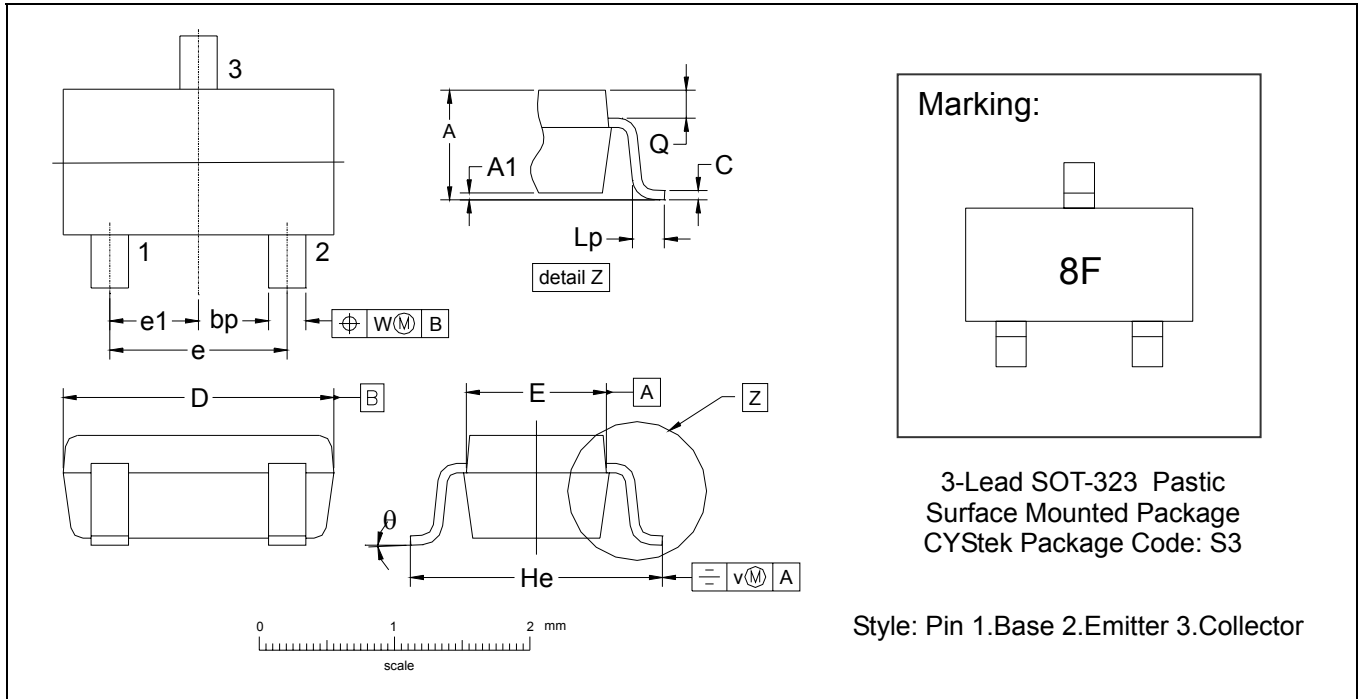

\*: Typical

DIM	Inches		Millimeters		DIM	Inches		Millimeters	
	Min.	Max.	Min.	Max.		Min.	Max.	Min.	Max.
A	0.0315	0.0433	0.80	1.10	e1	0.0256	-	0.65	-
A1	0.0000	0.0039	0.00	0.10	He	0.0787	0.0886	2.00	2.25
bp	0.0118	0.0157	0.30	0.40	Lp	0.0059	0.0177	0.15	0.45
C	0.0039	0.0098	0.10	0.25	Q	0.0051	0.0091	0.13	0.23
D	0.0709	0.0866	1.80	2.20	v	0.0079	-	0.2	-
E	0.0453	0.0531	1.15	1.35	w	0.0079	-	0.2	-
e	0.0512	-	1.3	-	θ	-	-	10°	0°

Notes: 1.Dimension and tolerance based on our Spec. dated Feb. 27.002.  
 2.Controlling dimension: millimeters.  
 3.Maximum lead thickness includes lead finish thickness, and minimum lead thickness is the minimum thickness of base material.  
 4.If there is any question with packing specification or packing method, please contact your local CYStek sales office.

**Material:**

- Lead: 42 Alloy ; solder plating
- Mold Compound: Epoxy resin family, flammability solid burning class: UL94V-0

**Important Notice:**

- All rights are reserved. Reproduction in whole or in part is prohibited without the prior written approval of CYStek.
- CYStek reserves the right to make changes to its products without notice.
- CYStek **semiconductor products are not warranted to be suitable for use in Life-Support Applications, or systems.**
- CYStek assumes no liability for any consequence of customer product design, infringement of patents, or application assistance.