

**Low Vcesat NPN Epitaxial Planar Transistor**

# BTN853L3

$BV_{CEO}$	60V
$I_D$	5.2A
$R_{CESAT(max)}$	55m $\Omega$

**Features**

- Extremely low equivalent on resistance;  $R_{CE(SAT)} \leq 60m\Omega$  at 5.2A
- 5.2A continuous collector current (10.4A peak)
- Very low saturation voltages
- Excellent gain characteristics
- Pb-free package

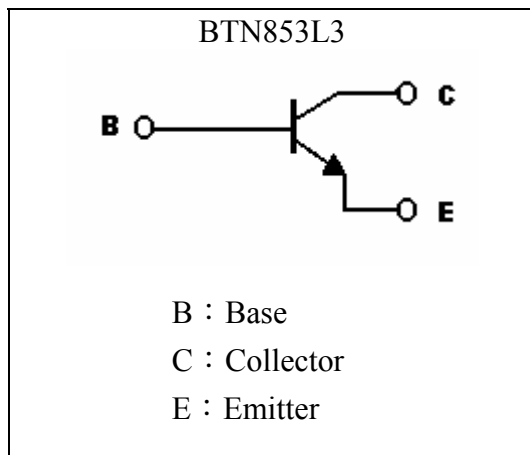
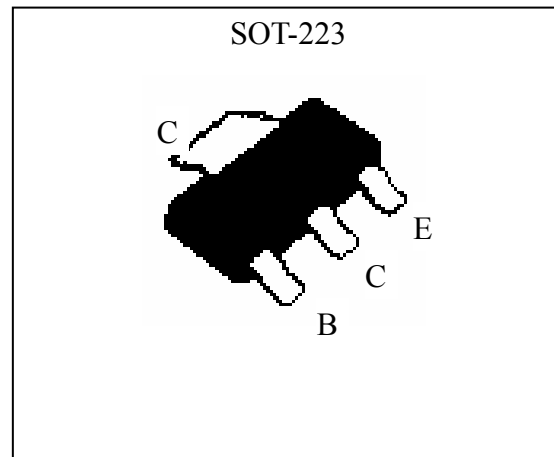
**Symbol**

**Outline**

**Absolute Maximum Ratings** ( $T_a=25^\circ\text{C}$ )

Parameter	Symbol	Limits	Unit
Collector-Base Voltage	$V_{CBO}$	60	V
Collector-Emitter Voltage	$V_{CEO}$	60	V
Emitter-Base Voltage	$V_{EBO}$	6	V
Collector Current (DC)	$I_C$	5.2	A
Collector Current (Pulse)	$I_{CP}$	10.2 (Note 1)	
Power Dissipation @ $T_A=25^\circ\text{C}$	$P_{tot}$	0.7 (Note 2)	W
		1.7 (Note 3)	
		2 (Note 4)	
Junction Temperature	$T_j$	150	$^\circ\text{C}$
Storage Temperature	$T_{stg}$	-55~+150	$^\circ\text{C}$



**Thermal Data**

Parameter	Symbol	Value	Unit
Thermal Resistance, Junction-to-ambient, max	R <sub>th,j-a</sub>	179 (Note 2)	°C/W
		74 (Note 3)	
		63 (Note 4)	
Thermal Resistance, Junction-to-solder point, max	R <sub>th,j-sp</sub>	15	°C/W

- Note :
1. Single Pulse , Pw≤300μs, Duty≤2%.
  2. Device mounted on an FR4 PCB, single-sided copper, tin plated and standard footprint.
  3. Device mounted on an FR4 PCB, single-sided copper, tin plated, mounting pad for collector 6 cm<sup>2</sup>.
  4. Device mounted on a ceramic PCB, Al<sub>2</sub>O<sub>3</sub>, standard footprint.

**Characteristics (Ta=25°C)**

Symbol	Min.	Typ.	Max.	Unit	Test Conditions
BV <sub>CBO</sub>	60	-	-	V	I <sub>C</sub> =100μA, I <sub>E</sub> =0
*BV <sub>CEO</sub>	60	-	-	V	I <sub>C</sub> =10mA, I <sub>B</sub> =0
BV <sub>EBO</sub>	6	-	-	V	I <sub>C</sub> =100μA, I <sub>C</sub> =0
I <sub>CBO</sub>	-	-	50	nA	V <sub>CB</sub> =60V, I <sub>E</sub> =0
I <sub>EBO</sub>	-	-	50	nA	V <sub>EB</sub> =6V, I <sub>C</sub> =0
*V <sub>CE(sat)</sub> 1	-	25	35	mV	I <sub>C</sub> =500mA, I <sub>B</sub> =50mA
*V <sub>CE(sat)</sub> 2	-	50	70	mV	I <sub>C</sub> =1A, I <sub>B</sub> =50mA
*V <sub>CE(sat)</sub> 3	-	95	120	mV	I <sub>C</sub> =1A, I <sub>B</sub> =10mA
*V <sub>CE(sat)</sub> 4	-	120	150	mV	I <sub>C</sub> =2A, I <sub>B</sub> =40mA
*V <sub>CE(sat)</sub> 5	-	160	220	mV	I <sub>C</sub> =4A, I <sub>B</sub> =200mA
*V <sub>CE(sat)</sub> 6	-	150	210	mV	I <sub>C</sub> =4A, I <sub>B</sub> =400mA
*V <sub>CE(sat)</sub> 7	-	230	305	mV	I <sub>C</sub> =4A, I <sub>B</sub> =80mA
*V <sub>CE(sat)</sub> 8	-	210	280	mV	I <sub>C</sub> =5.2A, I <sub>B</sub> =260mA
*R <sub>CE(sat)</sub> 1	-	40	55	mΩ	I <sub>C</sub> =4A, I <sub>B</sub> =200mA
*R <sub>CE(sat)</sub> 2	-	58	76	mΩ	I <sub>C</sub> =4A, I <sub>B</sub> =80mA
*V <sub>BE(sat)</sub> 1	-	0.8	0.9	V	I <sub>C</sub> =1A, I <sub>B</sub> =100mA
*V <sub>BE(sat)</sub> 2	-	0.94	1.05	V	I <sub>C</sub> =4A, I <sub>B</sub> =400mA
*V <sub>BE(on)</sub>	-	0.75	0.85	V	V <sub>CE</sub> =2V, I <sub>C</sub> =2A
*h <sub>FE</sub> 1	200	-	-	-	V <sub>CE</sub> =1V, I <sub>C</sub> =10mA
*h <sub>FE</sub> 2	200	320	500	-	V <sub>CE</sub> =1V, I <sub>C</sub> =1A
*h <sub>FE</sub> 3	35	-	-	-	V <sub>CE</sub> =1V, I <sub>C</sub> =7A
f <sub>T</sub>	-	100	-	MHz	V <sub>CE</sub> =10V, I <sub>C</sub> =100mA, f=50MHz
C <sub>ob</sub>	-	75	-	pF	V <sub>CB</sub> =10V, f=1MHz
t <sub>on</sub>	-	45	-	ns	V <sub>CC</sub> =10V, I <sub>C</sub> =10I <sub>B1</sub> =-10I <sub>B2</sub> =1A, R <sub>L</sub> =10Ω
t <sub>off</sub>	-	630	-	ns	

\*Pulse Test : Pulse Width ≤300μs, Duty Cycle ≤2%

**Typical Characteristics**

Current Gain vs Collector Current

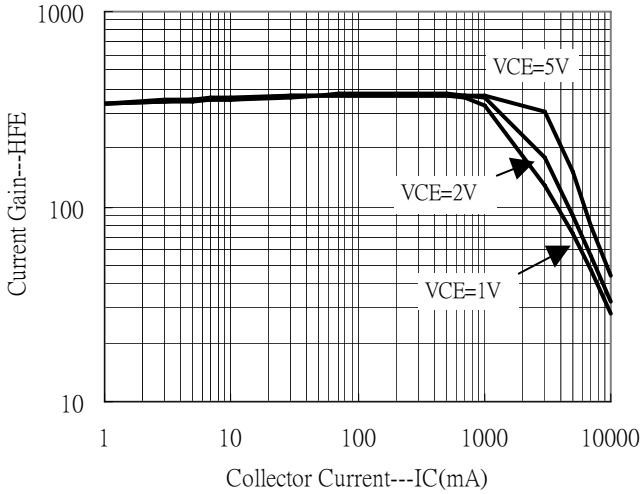

Saturation Voltage vs Collector Current

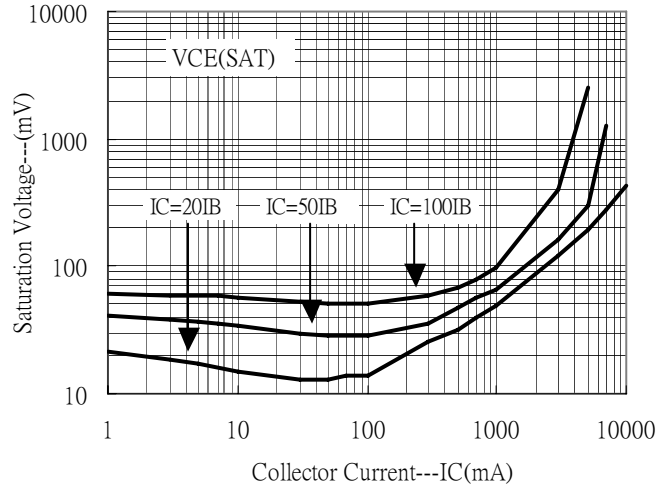

Saturation Voltage vs Collector Current

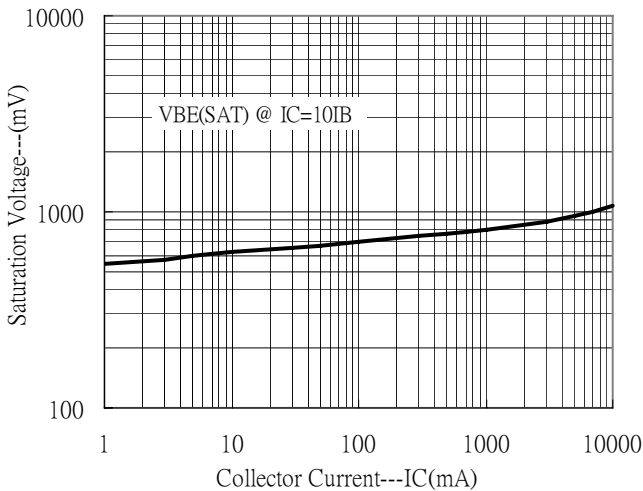

On Voltage vs Collector Current

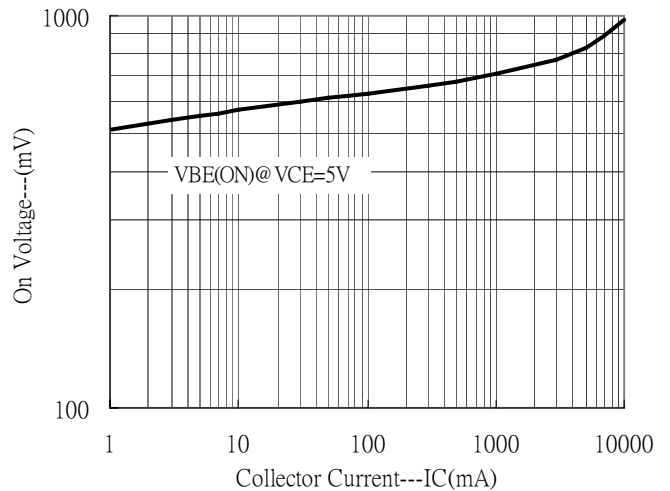

Grounded Emitter Output Characteristics

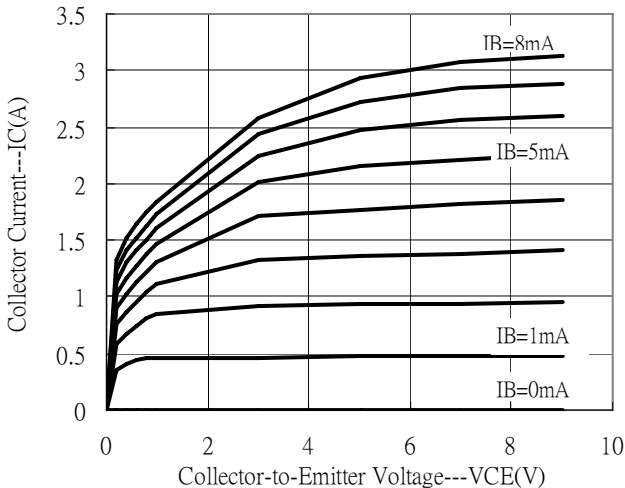

Grounded Emitter Output Characteristics

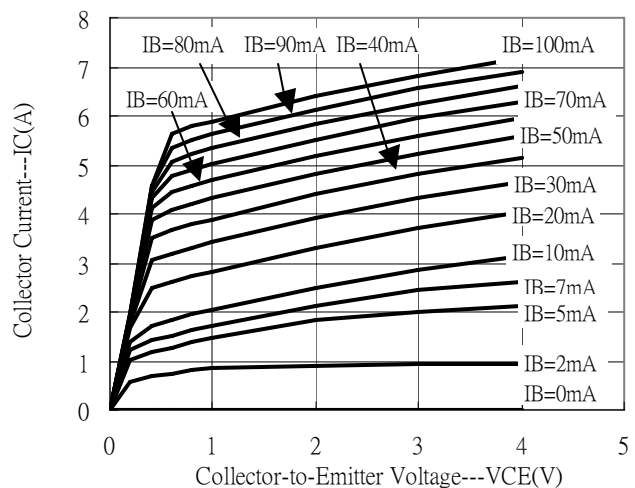

**Typical Characteristics(Cont.)**

Power Derating Curves

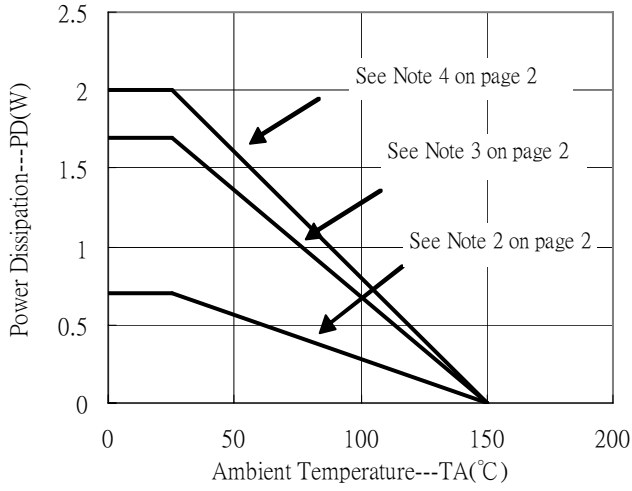

**Ordering Information**

Device	Package	Shipping	Marking
BTN853L3	SOT-223 (Pb-free)	2500 pcs / Tape & Reel	853

**Recommended soldering footprint**

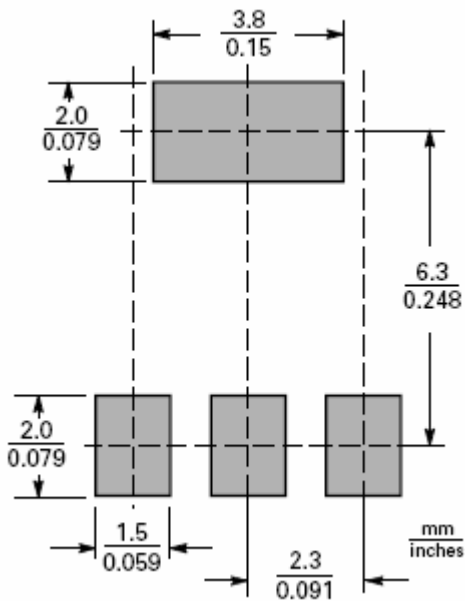

**Reel Dimension**

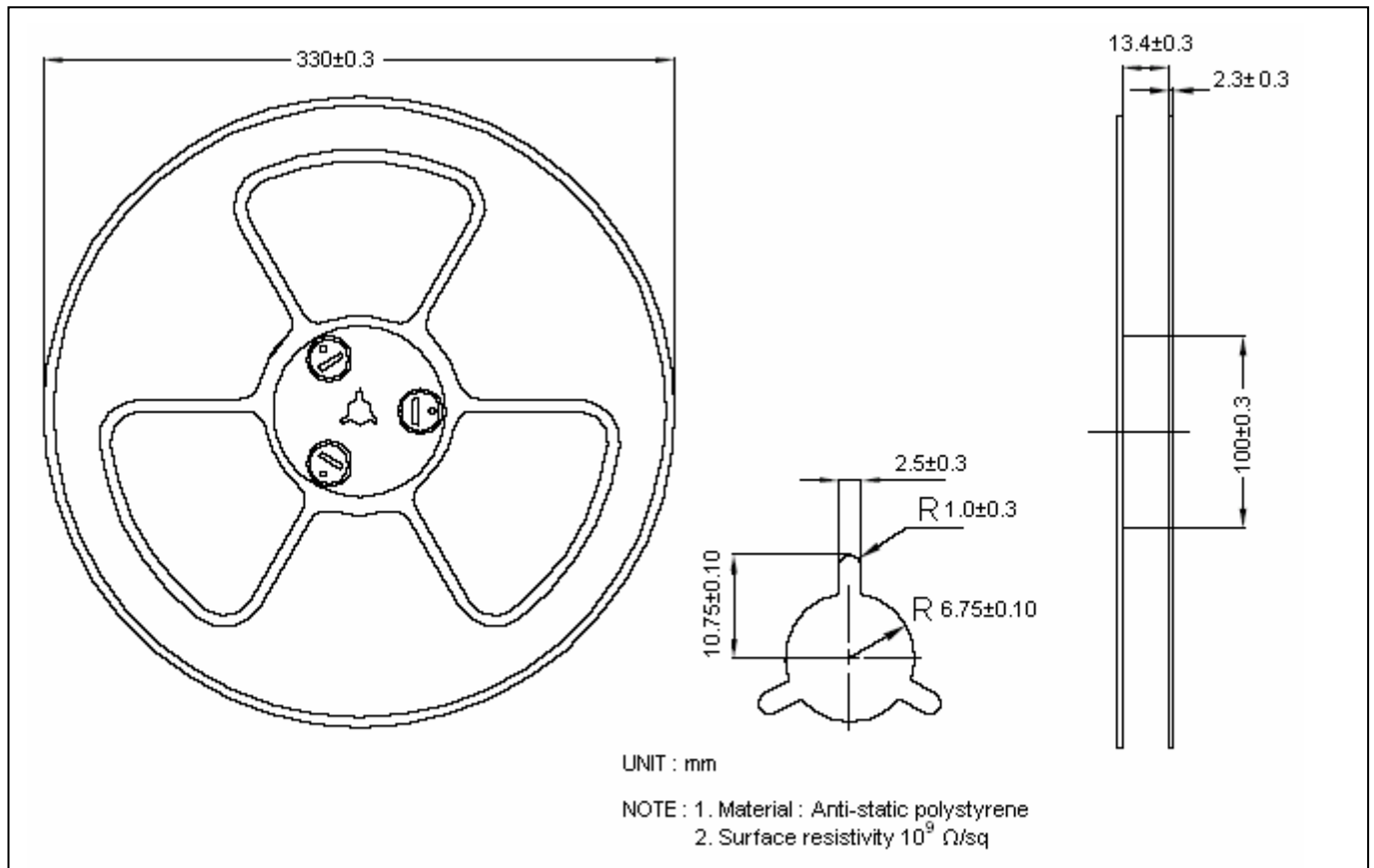

**Carrier Tape Dimension**

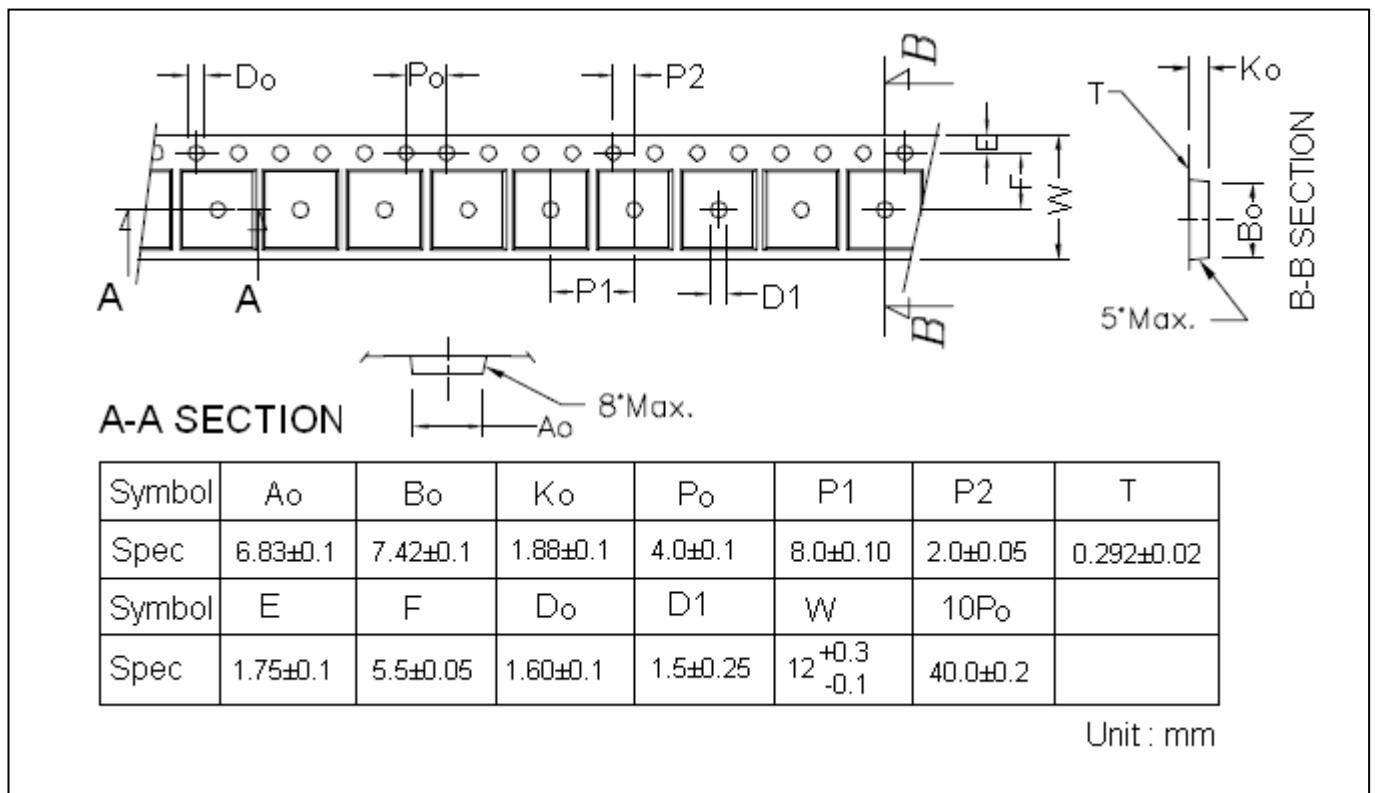

**Recommended wave soldering condition**

Product	Peak Temperature	Soldering Time
Pb-free devices	260 +0/-5 °C	5 +1/-1 seconds

**Recommended temperature profile for IR reflow**

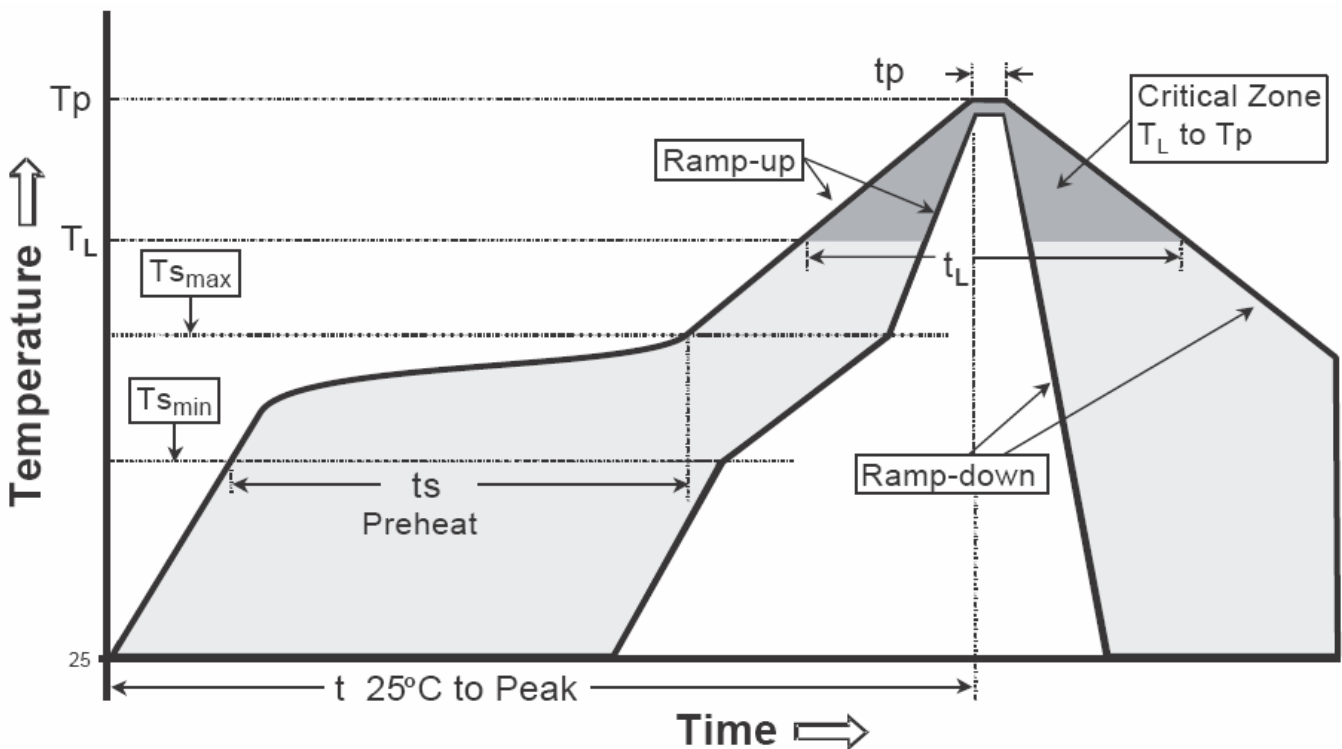

Profile feature	Sn-Pb eutectic Assembly	Pb-free Assembly
Average ramp-up rate (T <sub>smax</sub> to T <sub>p</sub> )	3°C/second max.	3°C/second max.
Preheat		
-Temperature Min(T <sub>s min</sub> )	100°C	150°C
-Temperature Max(T <sub>s max</sub> )	150°C	200°C
-Time(t <sub>s min</sub> to t <sub>s max</sub> )	60-120 seconds	60-180 seconds
Time maintained above:		
-Temperature (T <sub>L</sub> )	183°C	217°C
- Time (t <sub>L</sub> )	60-150 seconds	60-150 seconds
Peak Temperature(T <sub>p</sub> )	240 +0/-5 °C	260 +0/-5 °C
Time within 5°C of actual peak temperature(t <sub>p</sub> )	10-30 seconds	20-40 seconds
Ramp down rate	6°C/second max.	6°C/second max.
Time 25 °C to peak temperature	6 minutes max.	8 minutes max.

Note : All temperatures refer to topside of the package, measured on the package body surface.

**SOT-223 Dimension**

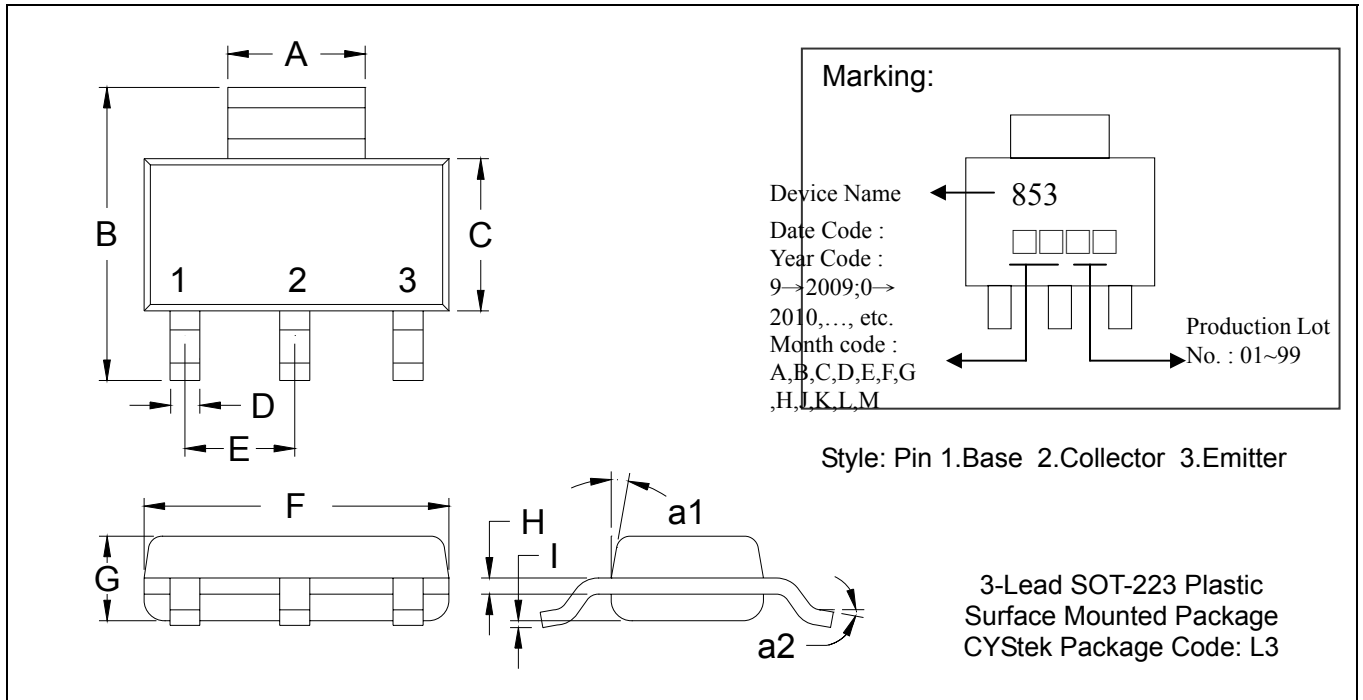

\*: Typical

DIM	Inches		Millimeters		DIM	Inches		Millimeters	
	Min.	Max.	Min.	Max.		Min.	Max.	Min.	Max.
A	0.1142	0.1220	2.90	3.10	G	0.0551	0.0709	1.40	1.80
B	0.2638	0.2874	6.70	7.30	H	0.0098	0.0138	0.25	0.35
C	0.1299	0.1457	3.30	3.70	I	0.0008	0.0039	0.02	0.10
D	0.0236	0.0315	0.60	0.80	a1	*13°	-	*13°	-
E	*0.0906	-	*2.30	-	a2	0°	10°	0°	10°
F	0.2480	0.2638	6.30	6.70					

- Notes: 1.Controlling dimension: millimeters.  
 2.Maximum lead thickness includes lead finish thickness, and minimum lead thickness is the minimum thickness of base material.  
 3.If there is any question with packing specification or packing method, please contact your local CYStek sales office.

**Material:**

- Lead: Pure tin plated
- Mold Compound: Epoxy resin family, flammability solid burning class: UL94V-0

**Important Notice:**

- All rights are reserved. Reproduction in whole or in part is prohibited without the prior written approval of CYStek.
- CYStek reserves the right to make changes to its products without notice.
- CYStek **semiconductor products are not warranted to be suitable for use in Life-Support Applications, or systems.**
- CYStek assumes no liability for any consequence of customer product design, infringement of patents, or application assistance.