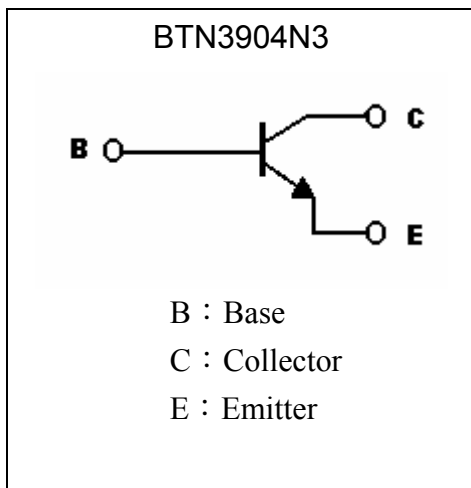
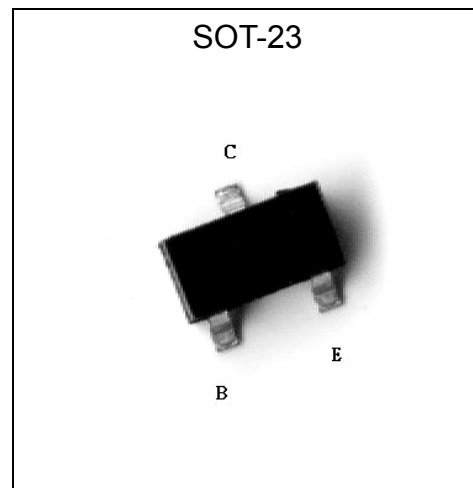

General Purpose NPN Epitaxial Planar Transistor

BTN3904N3

Description

- The BTN3904N3 is designed for general purpose switching amplifier applications.
- Complementary to BTP3906N3.
- Pb-free lead plating and halogen-free package

Symbol

Outline

Absolute Maximum Ratings (Ta=25°C)

Parameter	Symbol	Limits	Unit
Collector-Base Voltage	V _{CB0}	60	V
Collector-Emitter Voltage	V _{CEO}	40	V
Emitter-Base Voltage	V _{EBO}	6	V
Collector Current	I _C	200	mA
Power Dissipation (T _A =25°C)	P _D	225 (Note)	mW
Power Dissipation (T _C =25°C)	P _D	560	mW
Thermal Resistance, Junction to Ambient	R _{θJA}	556 (Note)	°C/W
Thermal Resistance, Junction to Case	R _{θJC}	223	°C/W
Junction Temperature	T _j	150	°C
Storage Temperature	T _{stg}	-55~+150	°C

Note : Free air condition



Characteristics (Ta=25°C)

Symbol	Min.	Typ.	Max.	Unit	Test Conditions
BV _{CBO}	60	-	-	V	I _C =10μA
BV _{CEO}	40	-	-	V	I _C =1mA
BV _{EBO}	6	-	-	V	I _E =10μA
I _{CEX}	-	-	50	nA	V _{CE} =30V, V _{BE} =-3V
*V _{CE(sat)1}	-	0.1	0.2	V	I _C =10mA, I _B =1mA
*V _{CE(sat)2}	-	0.15	0.3	V	I _C =50mA, I _B =5mA
*V _{BE(sat)1}	0.65	0.75	0.85	V	I _C =10mA, I _B =1mA
*V _{BE(sat)2}	-	0.85	0.95	V	I _C =50mA, I _B =5mA
*h _{FE1}	40	-	-		V _{CE} =1V, I _C =100μA
*h _{FE2}	70	-	-		V _{CE} =1V, I _C =1mA
*h _{FE3}	100	-	300		V _{CE} =1V, I _C =10mA
*h _{FE4}	60	-	-		V _{CE} =1V, I _C =50mA
*h _{FE5}	30	-	-		V _{CE} =1V, I _C =100mA
f _T	300	-	-	MHz	V _{CE} =20V, I _C =10mA, f=100MHz
C _{ob}	-	-	4	pF	V _{CB} =5V, I _E =0A, f=1MHz

*Pulse Test: Pulse Width ≤380μs, Duty Cycle≤2%

Ordering Information

Device	Package	Shipping
BTN3904N3-0-T1-G	SOT-23 (Pb-free lead plating and halogen-free package)	3000 pcs / Tape & Reel

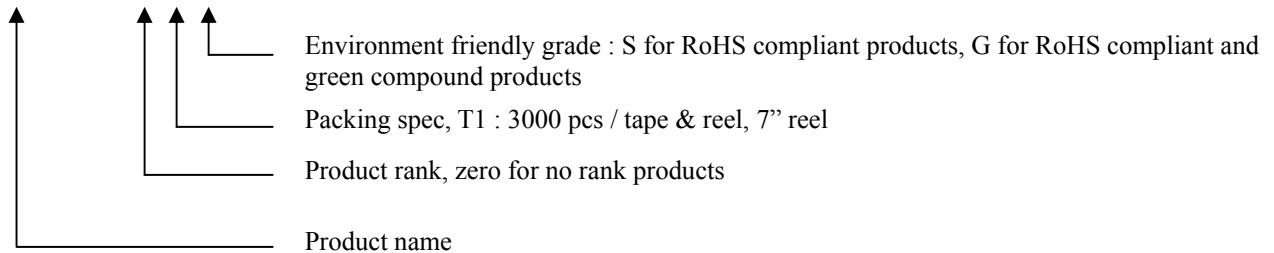

Recommended Soldering Footprint

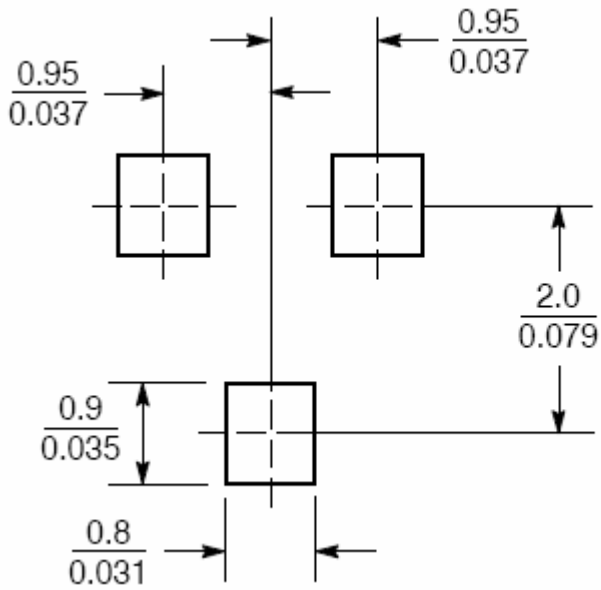

Unit : $\frac{\text{mm}}{\text{inches}}$

Characteristic Curves

Saturation Voltage vs Collector Current

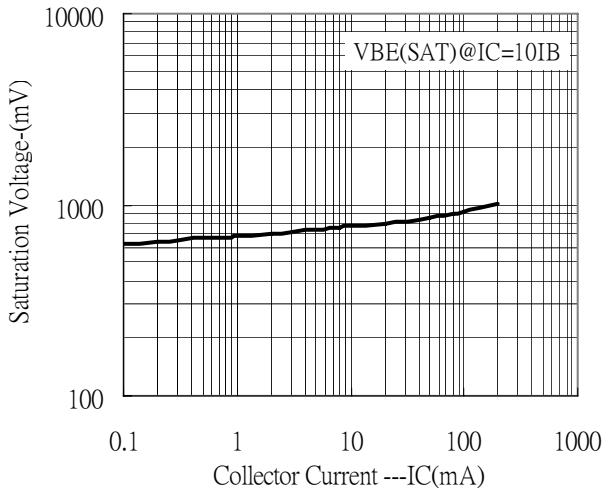

Current Gain vs Collector Current

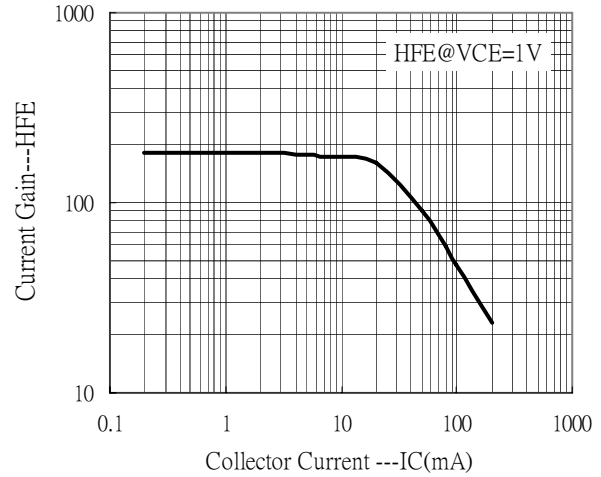

Saturation Voltage vs Collector Current

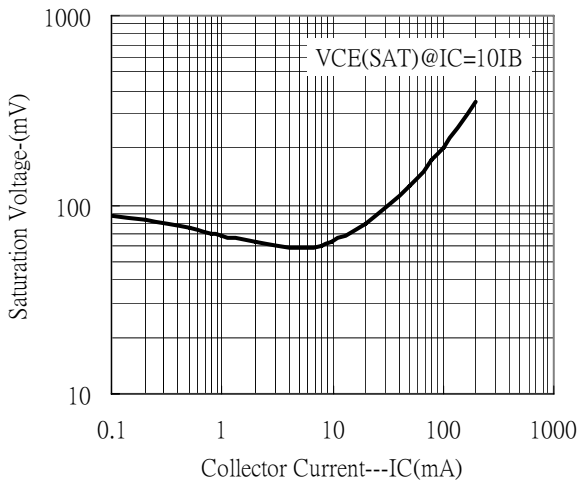

Cutoff Frequency vs Collector Current

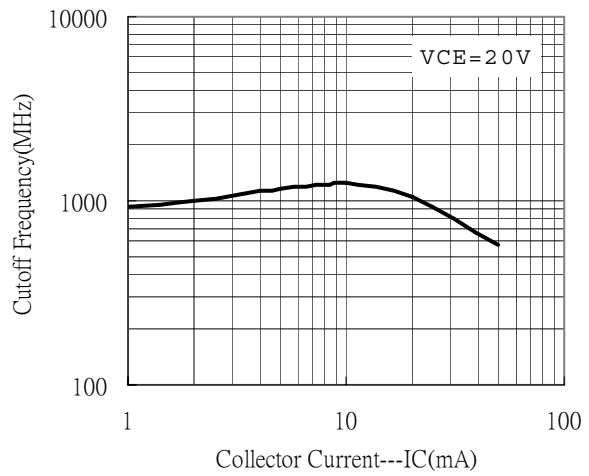

Power Derating Curve

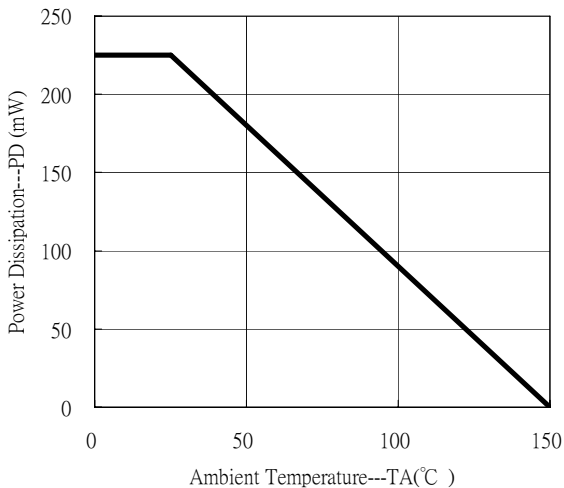

Reel Dimension

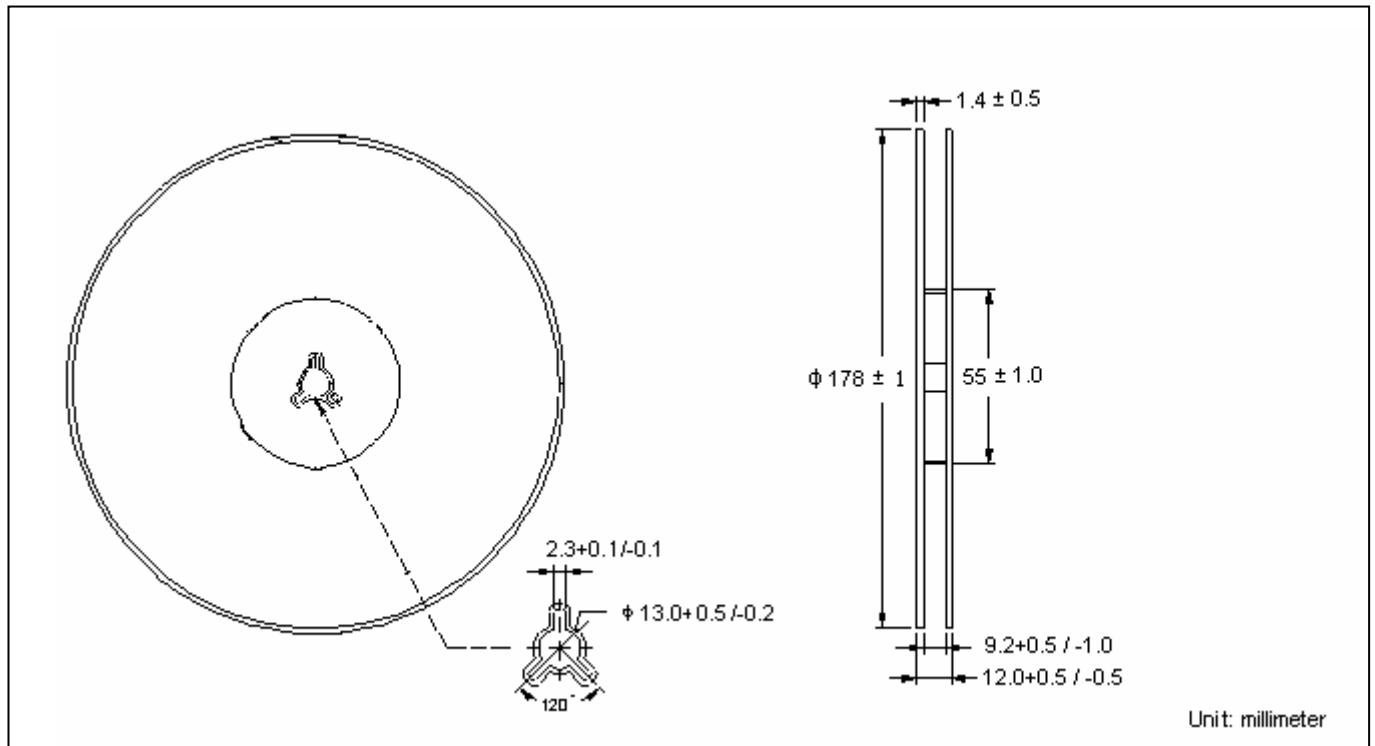

Carrier Tape Dimension

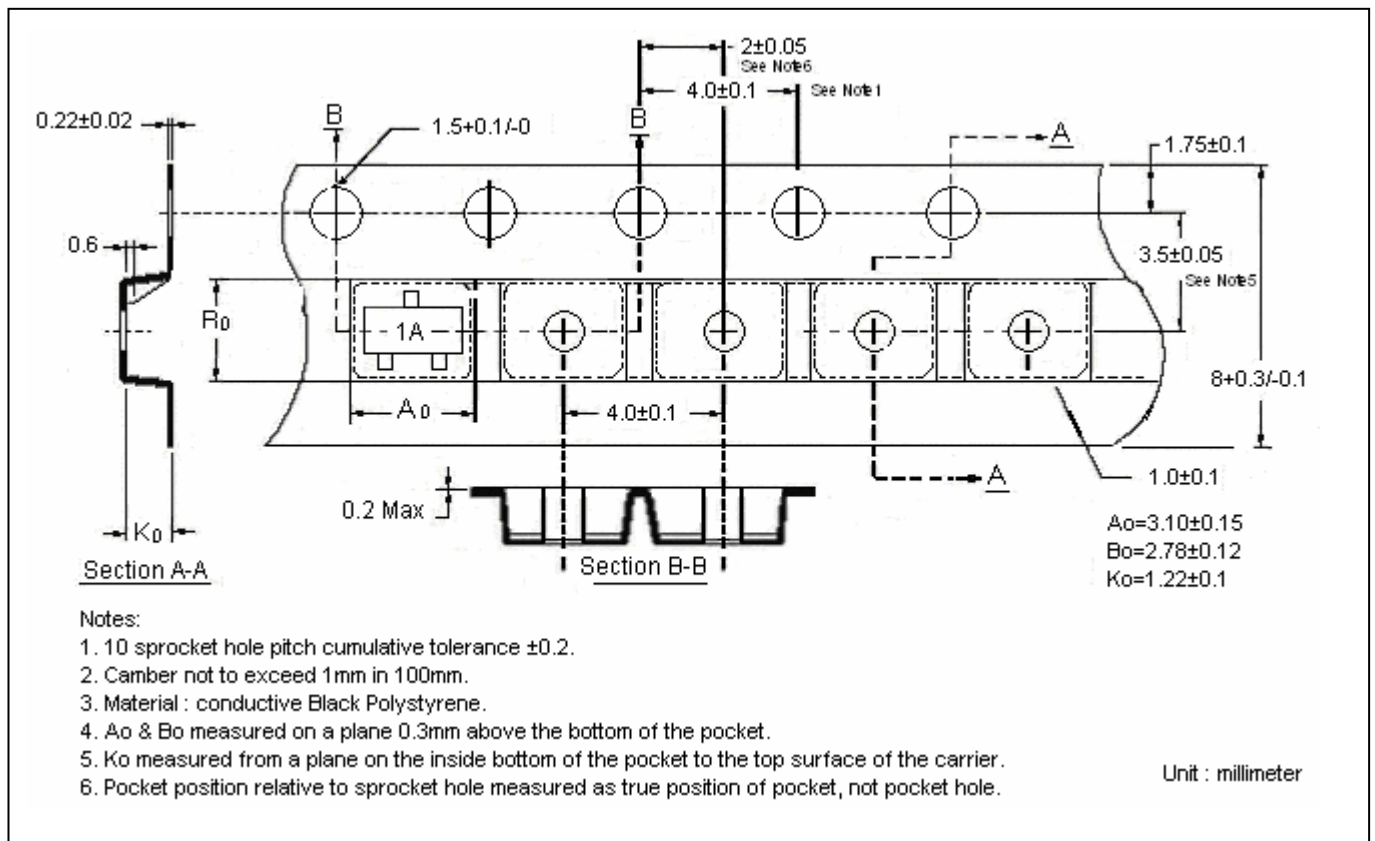

Recommended wave soldering condition

Product	Peak Temperature	Soldering Time
Pb-free devices	260 +0/-5 °C	5 +1/-1 seconds

Recommended temperature profile for IR reflow

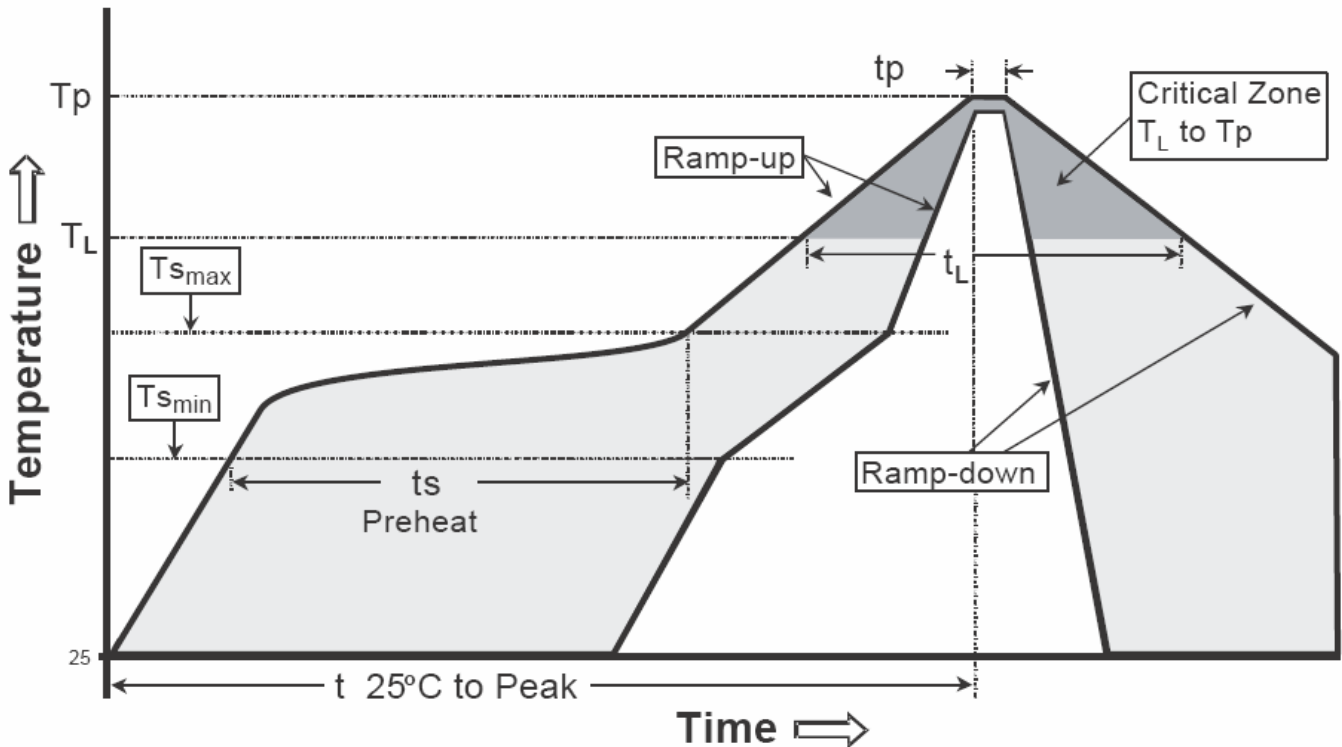

Profile feature	Sn-Pb eutectic Assembly	Pb-free Assembly
Average ramp-up rate (T _{smax} to T _p)	3°C/second max.	3°C/second max.
Preheat		
-Temperature Min(T _{s min})	100°C	150°C
-Temperature Max(T _{s max})	150°C	200°C
-Time(t _{s min} to t _{s max})	60-120 seconds	60-180 seconds
Time maintained above:		
-Temperature (T _L)	183°C	217°C
- Time (t _L)	60-150 seconds	60-150 seconds
Peak Temperature(T _P)	240 +0/-5 °C	260 +0/-5 °C
Time within 5°C of actual peak temperature(tp)	10-30 seconds	20-40 seconds
Ramp down rate	6°C/second max.	6°C/second max.
Time 25 °C to peak temperature	6 minutes max.	8 minutes max.

Note : All temperatures refer to topside of the package, measured on the package body surface.

SOT-23 Dimension

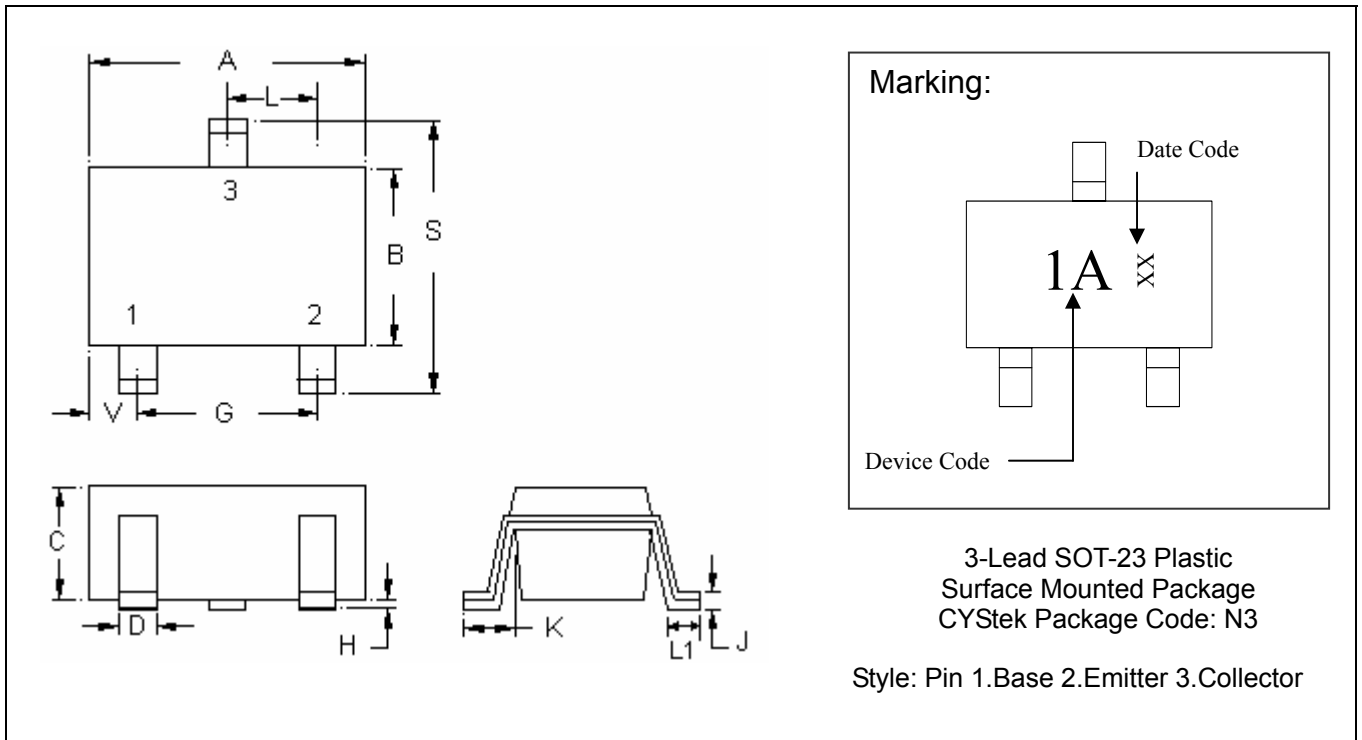

*: Typical

DIM	Inches		Millimeters		DIM	Inches		Millimeters	
	Min.	Max.	Min.	Max.		Min.	Max.	Min.	Max.
A	0.1102	0.1204	2.80	3.04	J	0.0032	0.0079	0.08	0.20
B	0.0472	0.0669	1.20	1.70	K	0.0118	0.0266	0.30	0.67
C	0.0335	0.0512	0.89	1.30	L	0.0335	0.0453	0.85	1.15
D	0.0118	0.0197	0.30	0.50	S	0.0830	0.1161	2.10	2.95
G	0.0669	0.0910	1.70	2.30	V	0.0098	0.0256	0.25	0.65
H	0.0000	0.0040	0.00	0.10	L1	0.0118	0.0197	0.30	0.50

Notes: 1.Controlling dimension: millimeters.
 2.Maximum lead thickness includes lead finish thickness, and minimum lead thickness is the minimum thickness of base material.
 3.If there is any question with packing specification or packing method, please contact your local CYStek sales office.

Material:

- Lead: Pure tin plated.
- Mold Compound: Epoxy resin family, flammability solid burning class: UL94V-0

Important Notice:

- All rights are reserved. Reproduction in whole or in part is prohibited without the prior written approval of CYStek.
- CYStek reserves the right to make changes to its products without notice.
- CYStek **semiconductor products are not warranted to be suitable for use in Life-Support Applications, or systems.**
- CYStek assumes no liability for any consequence of customer product design, infringement of patents, or application assistance.