

General Purpose NPN Epitaxial Planar Transistor

BTN6427N3

Description

- The BTN6427N3 is a darlington amplifier transistor
- Pb-free package.

Equivalent Circuit

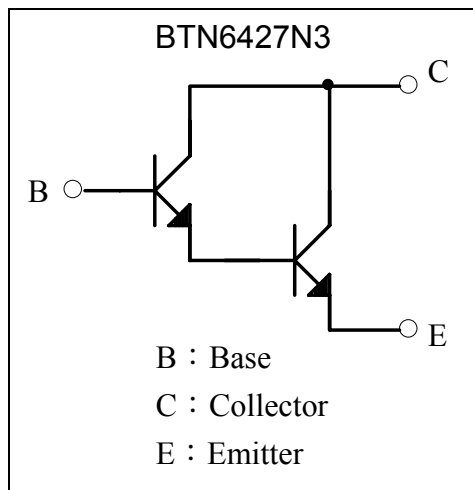

Outline

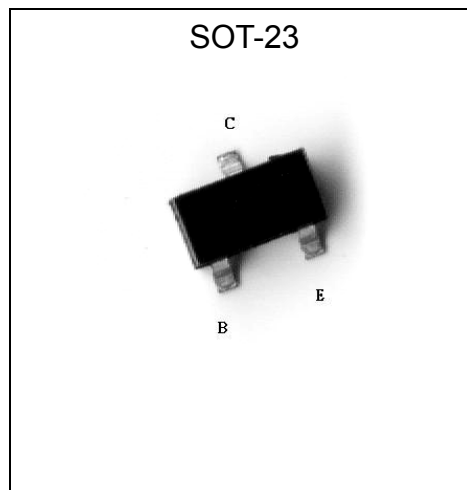

Absolute Maximum Ratings (Ta=25°C)

Parameter	Symbol	Limits	Unit
Collector-Base Voltage	V_{CBO}	100	V
Collector-Emitter Voltage	V_{CES}	60	V
Collector-Emitter Voltage	V_{CEO}	60	V
Emitter-Base Voltage	V_{EBO}	12	V
Collector Current	I_C	0.5	A
Power Dissipation	P_d	225	mW
Junction Temperature	T_j	150	°C
Storage Temperature	T_{stg}	-55~+150	°C

**Characteristics (Ta=25°C)**

Symbol	Min.	Typ.	Max.	Unit	Test Conditions
BV_{CBO}	100	-	-	V	$I_C=100\mu A$
BV_{CES}	60	-	-	V	$I_C=100\mu A, V_{BE}=0V$
BV_{CEO}	60	-	-	V	$I_C=10mA$
BV_{EBO}	12	-	-	V	$I_E=10\mu A$
I_{CBO}	-	-	50	nA	$V_{CB}=80V$
I_{EBO}	-	-	50	nA	$V_{EB}=10V$
* $V_{CE(sat)1}$	-	-	1.2	V	$I_C=50mA, I_B=0.5mA$
* $V_{CE(sat)2}$	-	-	1.5	V	$I_C=500mA, I_B=0.5mA$
* $V_{BE(sat)}$	-	-	2.0	V	$I_C=500mA, I_B=0.5mA$
* $V_{BE(on)}$	-	-	1.75	V	$V_{CE}=5V, I_C=50mA$
* h_{FE1}	10K	-	100K	-	$V_{CE}=5V, I_C=10mA$
* h_{FE2}	20K	-	200K	-	$V_{CE}=5V, I_C=100mA$
* h_{FE3}	14K	-	140K	-	$V_{CE}=5V, I_C=500mA$
Cob	-	-	7	pF	$V_{CB}=10V, f=100MHz$

*Pulse Test: Pulse Width $\leq 380\mu s$, Duty Cycle $\leq 2\%$ **Ordering Information**

Device	Package	Shipping	Marking
BTN6427N3	SOT-23 (Pb-free)	3000 pcs / Tape & Reel	1N

Characteristic Curves

Current Gain vs Collector Current

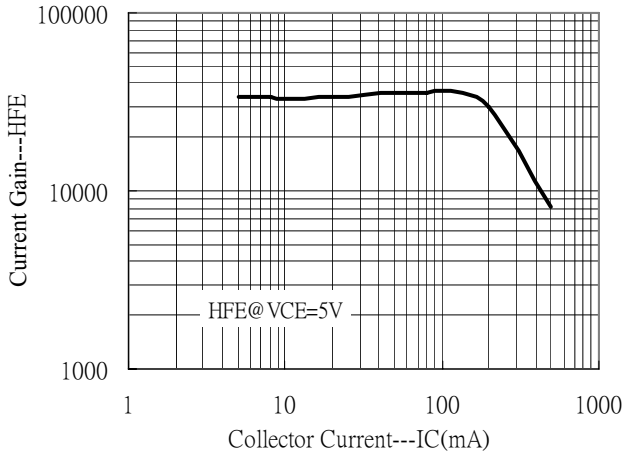

Saturation Voltage vs Collector Current

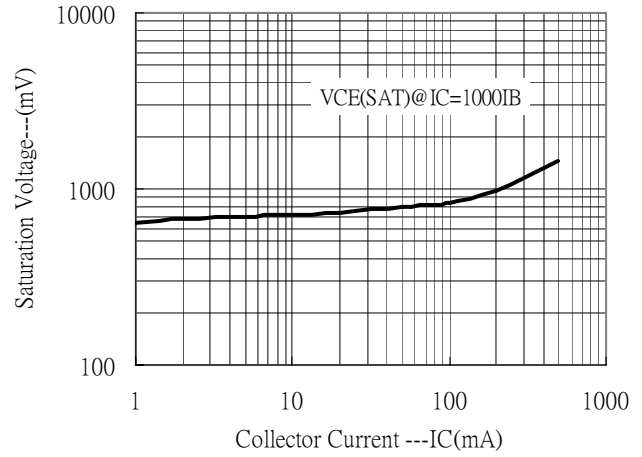

Saturation Voltage vs Collector Current

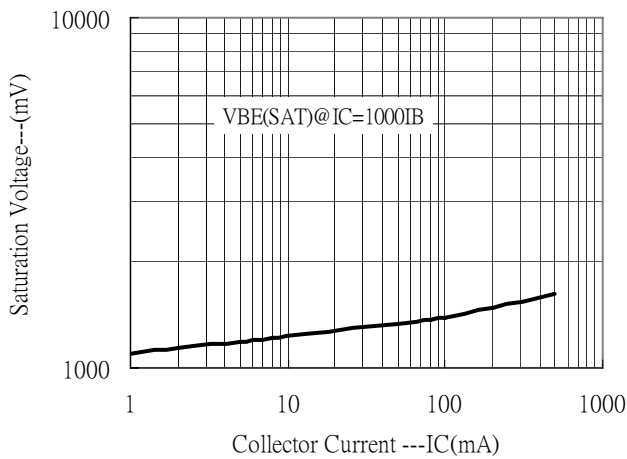

ON Voltage vs Collector Current

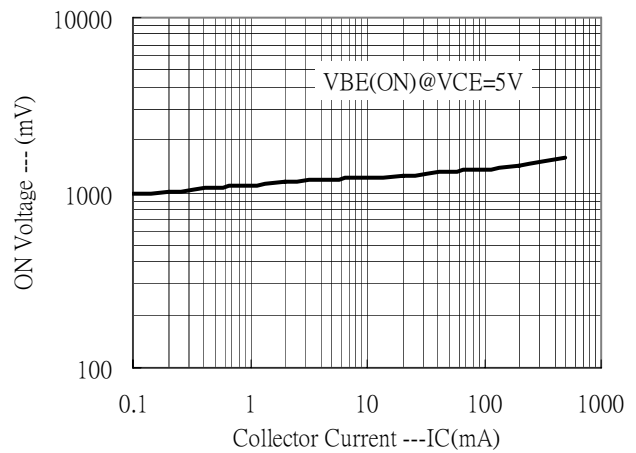

Power Derating Curve

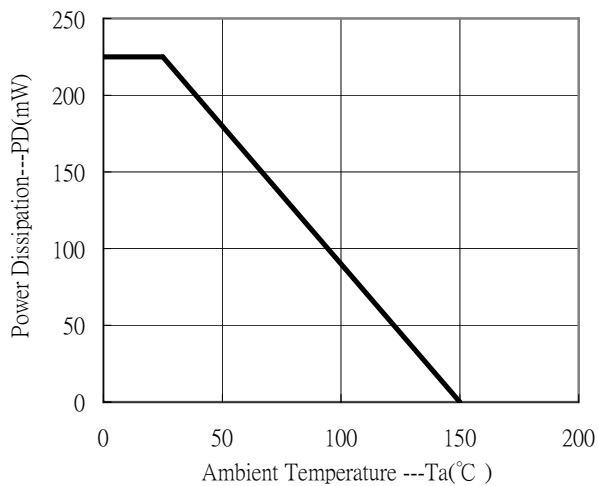

Reel Dimension

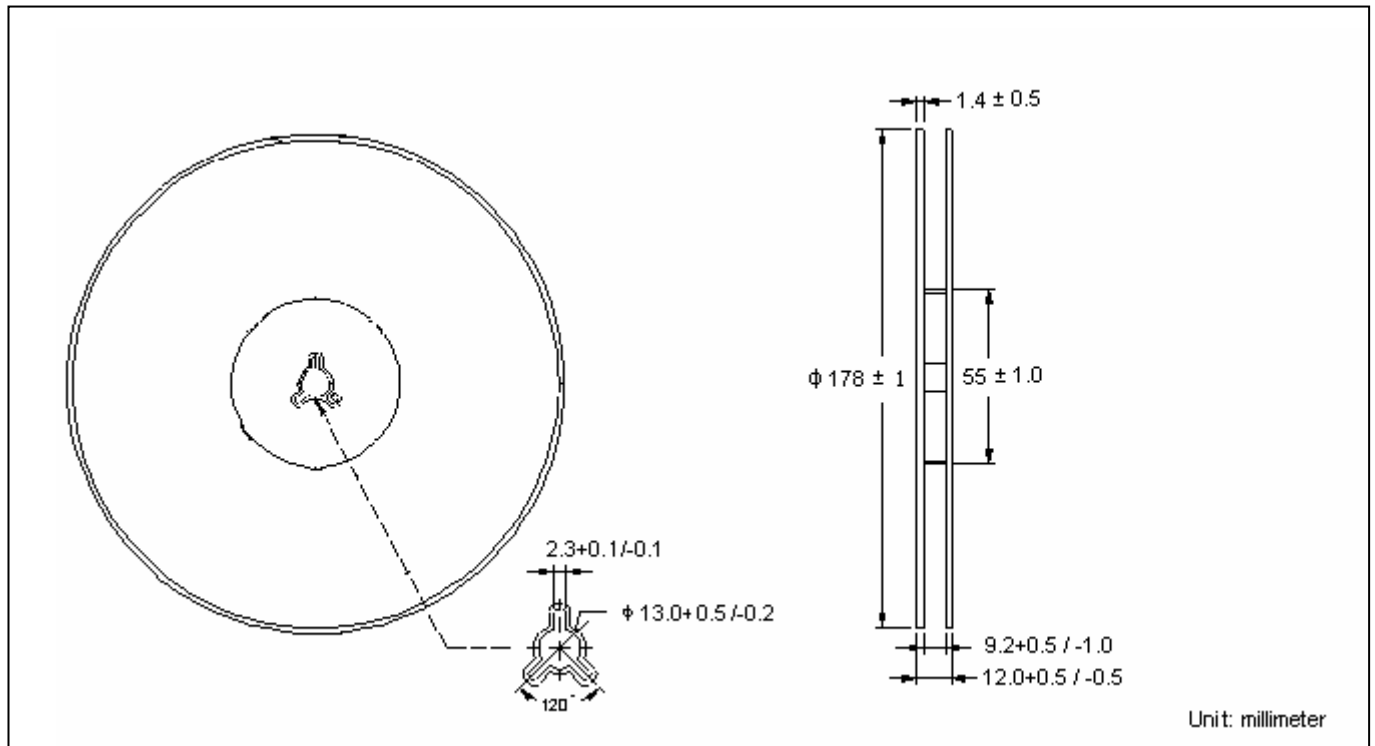

Carrier Tape Dimension

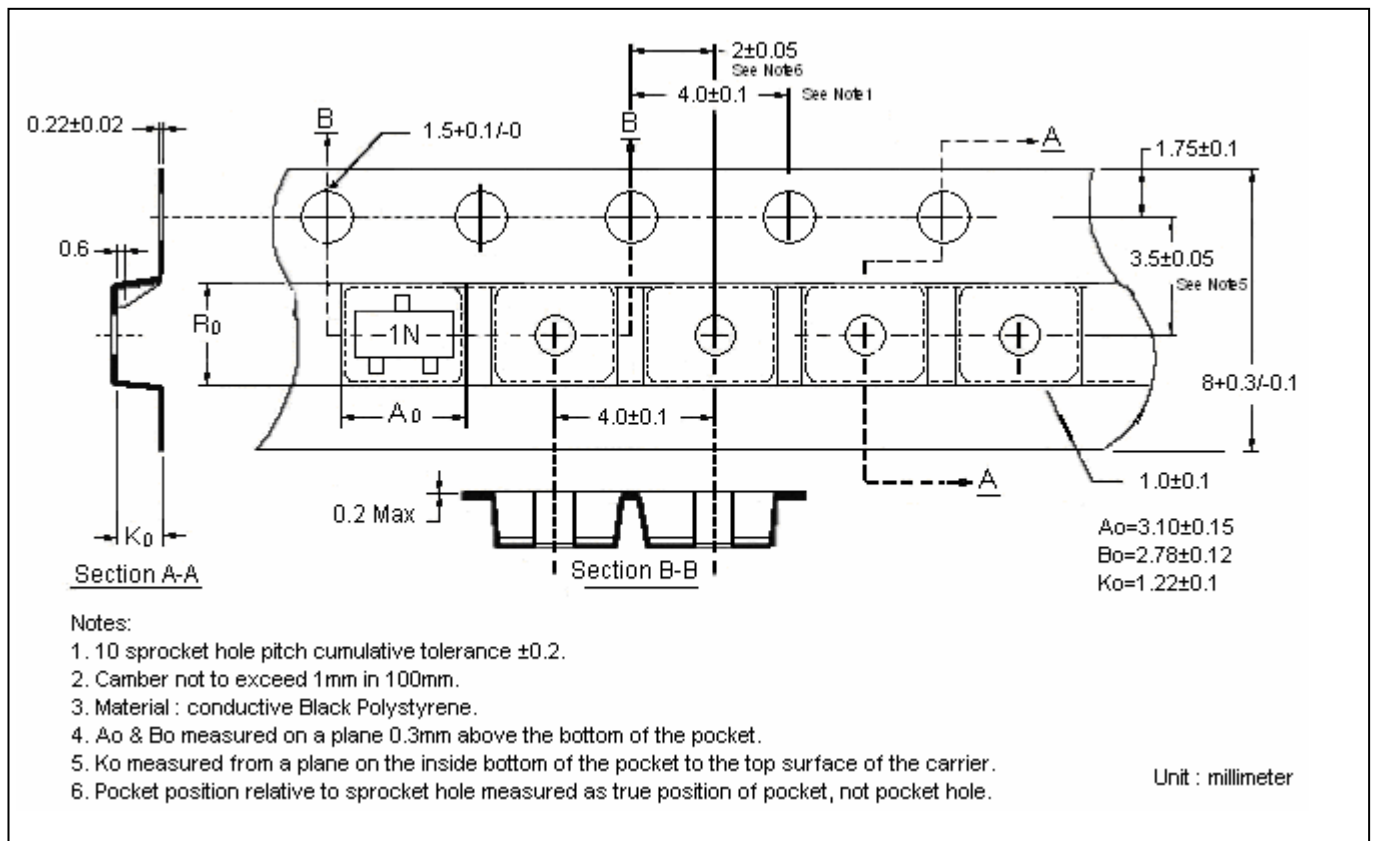

Recommended wave soldering condition

Product	Peak Temperature	Soldering Time
Pb-free devices	260 +0/-5 °C	5 +1/-1 seconds

Recommended temperature profile for IR reflow

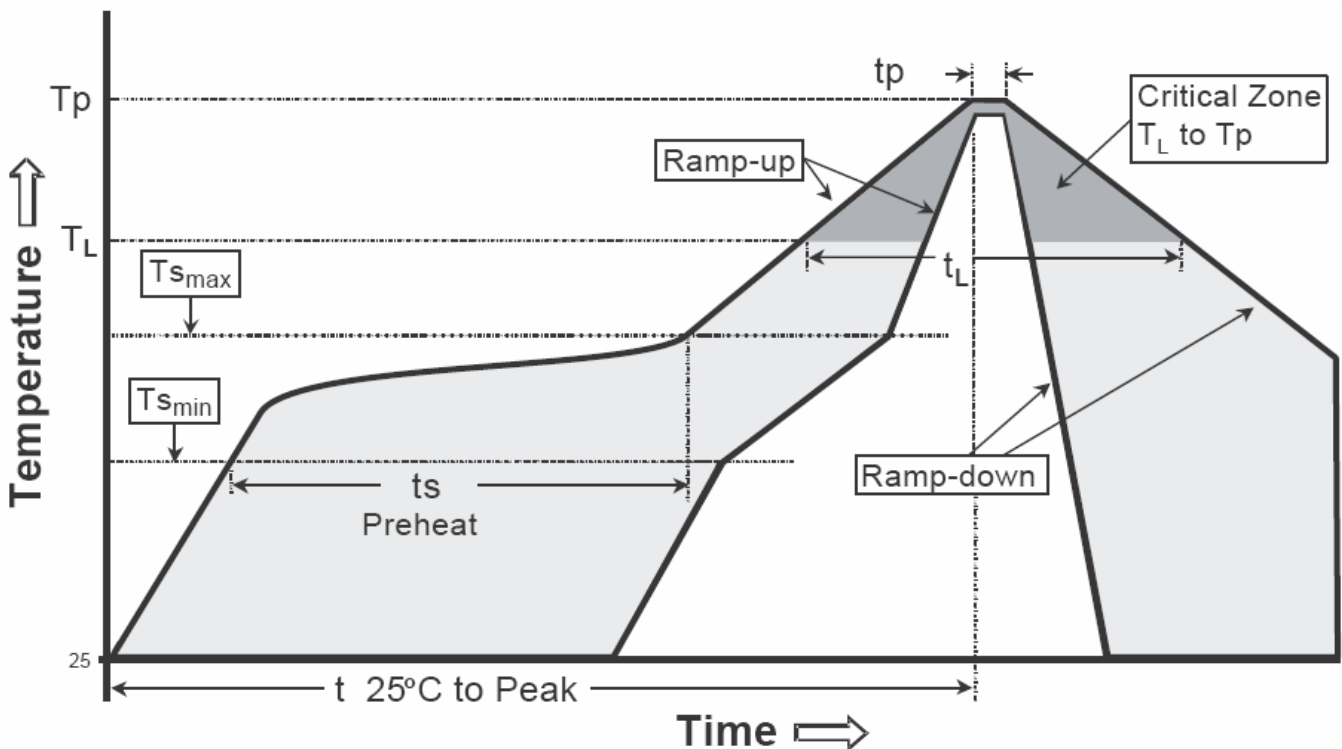

Profile feature	Sn-Pb eutectic Assembly	Pb-free Assembly
Average ramp-up rate (T _{smax} to T _p)	3°C/second max.	3°C/second max.
Preheat		
-Temperature Min(T _{s min})	100°C	150°C
-Temperature Max(T _{s max})	150°C	200°C
-Time(t _{s min} to t _{s max})	60-120 seconds	60-180 seconds
Time maintained above:		
-Temperature (T _L)	183°C	217°C
- Time (t _L)	60-150 seconds	60-150 seconds
Peak Temperature(T _P)	240 +0/-5 °C	260 +0/-5 °C
Time within 5°C of actual peak temperature(tp)	10-30 seconds	20-40 seconds
Ramp down rate	6°C/second max.	6°C/second max.
Time 25 °C to peak temperature	6 minutes max.	8 minutes max.

Note : All temperatures refer to topside of the package, measured on the package body surface.

SOT-23 Dimension

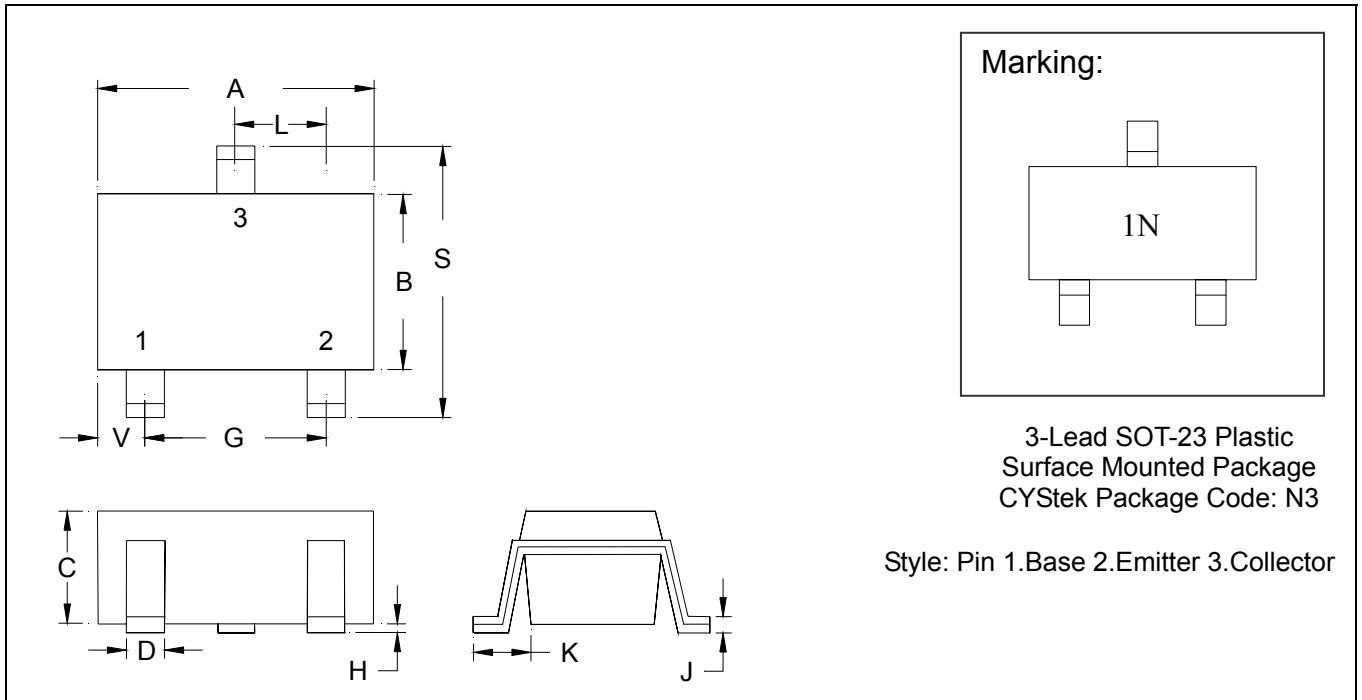

*: Typical

DIM	Inches		Millimeters		DIM	Inches		Millimeters	
	Min.	Max.	Min.	Max.		Min.	Max.	Min.	Max.
A	0.1102	0.1204	2.80	3.04	J	0.0034	0.0070	0.085	0.177
B	0.0472	0.0630	1.20	1.60	K	0.0128	0.0266	0.32	0.67
C	0.0335	0.0512	0.89	1.30	L	0.0335	0.0453	0.85	1.15
D	0.0118	0.0197	0.30	0.50	S	0.0830	0.1083	2.10	2.75
G	0.0669	0.0910	1.70	2.30	V	0.0098	0.0256	0.25	0.65
H	0.0005	0.0040	0.013	0.10					

- Notes:**
- Controlling dimension: millimeters.
 - Maximum lead thickness includes lead finish thickness, and minimum lead thickness is the minimum thickness of base material.
 - If there is any question with packing specification or packing method, please contact your local CYStek sales office.

Material:

- Lead: Pure tin plated.
- Mold Compound: Epoxy resin family, flammability solid burning class: UL94V-0.

Important Notice:

- All rights are reserved. Reproduction in whole or in part is prohibited without the prior written approval of CYStek.
- CYStek reserves the right to make changes to its products without notice.
- CYStek **semiconductor products are not warranted to be suitable for use in Life-Support Applications, or systems.**
- CYStek assumes no liability for any consequence of customer product design, infringement of patents, or application assistance.