

General Purpose PNP Epitaxial Planar Transistor

BTP2907AN3

Description

- The BTP2907AN3 is designed for general purpose amplifier applications. It is housed in the SOT-23 package which is designed for low power surface mount applications.
- Low $V_{CE(sat)}$
- High switching speed.
- Complementary to BTN2222AN3
- Pb-free package

Symbol

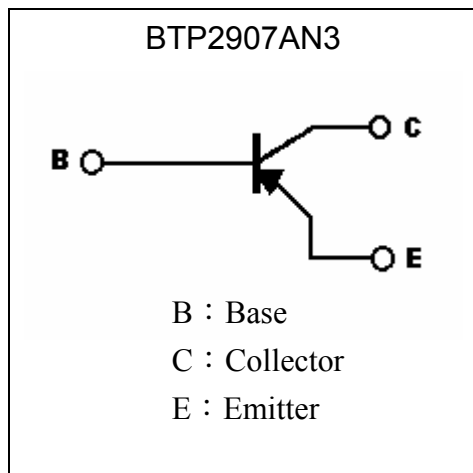

Outline

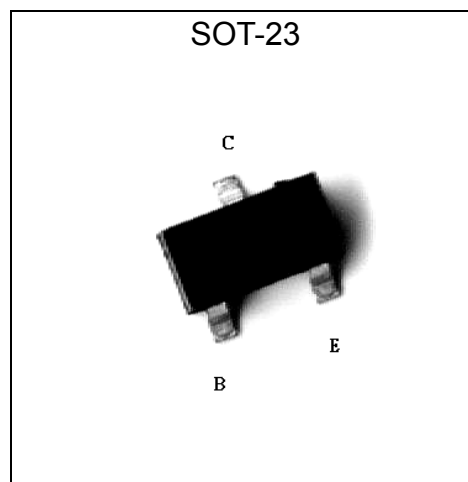

Absolute Maximum Ratings (Ta=25°C)

Parameter	Symbol	Limits	Unit
Collector-Base Voltage	V_{CBO}	-60	V
Collector-Emitter Voltage	V_{CEO}	-60	V
Emitter-Base Voltage	V_{EBO}	-5	V
Collector Current	I_C	-600	mA
Power Dissipation @ $T_A=25^\circ\text{C}$	P_d	225 (Note 1)	mW
Thermal Resistance, Junction to Ambient	$R_{\theta JA}$	556 (Note 1)	$^\circ\text{C}/\text{W}$
Junction Temperature	T_j	150	$^\circ\text{C}$
Storage Temperature	T_{stg}	-55~+150	$^\circ\text{C}$

Note 1: When mounted on a FR-5 board with area measuring 1.0x0.75x0.062 in.



Characteristics (Ta=25°C)

Symbol	Min.	Typ.	Max.	Unit	Test Conditions
BVCBO	-60	-	-	V	IC=-10μA
*BVCEO	-60	-	-	V	IC=-10mA
BVEBO	-5	-	-	V	IE=-10μA
ICBO	-	-	-10	nA	VCB=-50V
ICEX	-	-	-50	nA	VCE=-30V, VBE(OFF)=0.5V
*VCE(sat)	-	-0.2	-0.4	V	IC=-150mA, IB=-15mA
*VCE(sat)	-	-0.5	-1.6	V	IC=-500mA, IB=-50mA
*VBE(sat)	-	-	-1.3	V	IC=-150mA, IB=-15mA
*VBE(sat)	-	-	-2.6	V	IC=-500mA, IB=-50mA
*hFE	75	-	-	-	VCE=-10V, IC=-100μA
*hFE	100	-	-	-	VCE=-10V, IC=-1mA
*hFE	100	-	-	-	VCE=-10V, IC=-10mA
*hFE	100	-	300	-	VCE=-10V, IC=-150mA
*hFE	50	-	-	-	VCE=-10V, IC=-500mA
fT	200	-	-	MHz	VCE=-20V, IC=-50mA, f=100MHz
Cob	-	-	8	pF	VCB=-10V, IE=0A, f=1MHz

*Pulse Test: Pulse Width ≤380μs, Duty Cycle ≤2%

Ordering Information

Device	Package	Shipping	Marking
BTP2907AN3	SOT-23 (Pb-free)	3000 pcs / Tape & Reel	2F



Characteristic Curves

Current Gain vs Collector Current

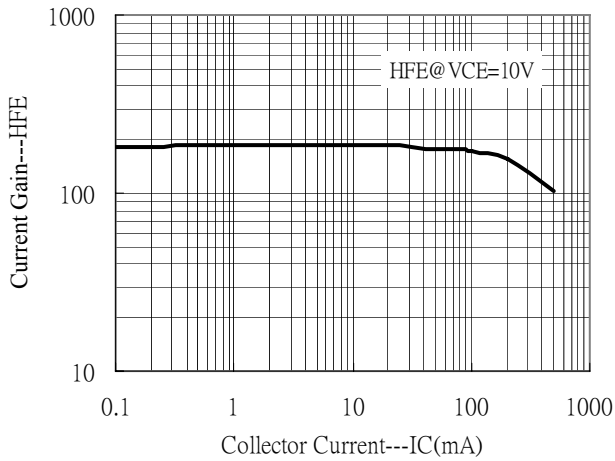

Saturation Voltage vs Collector Current

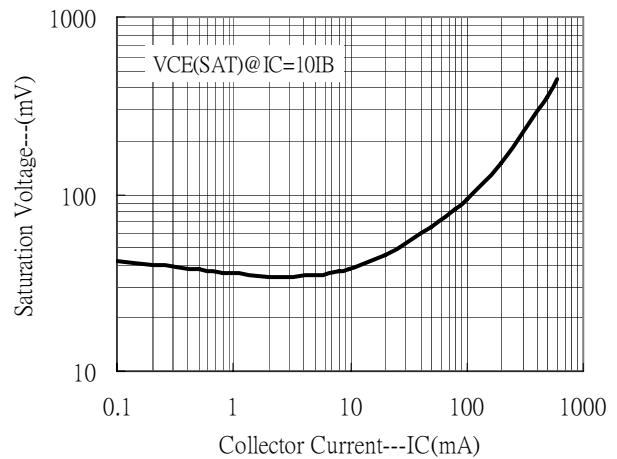

Saturation Voltage vs Collector Current

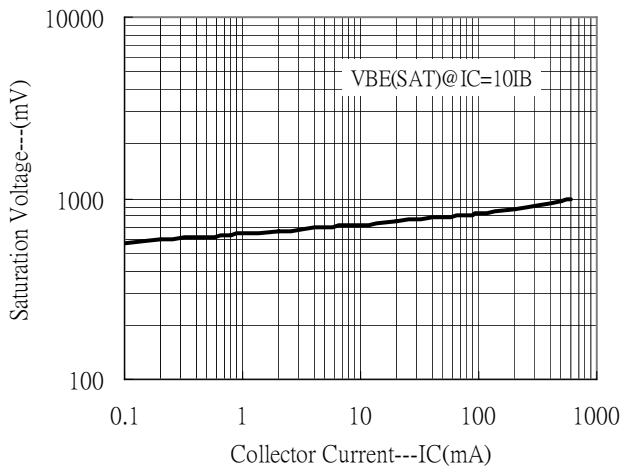

Cutoff Frequency vs Collector Current

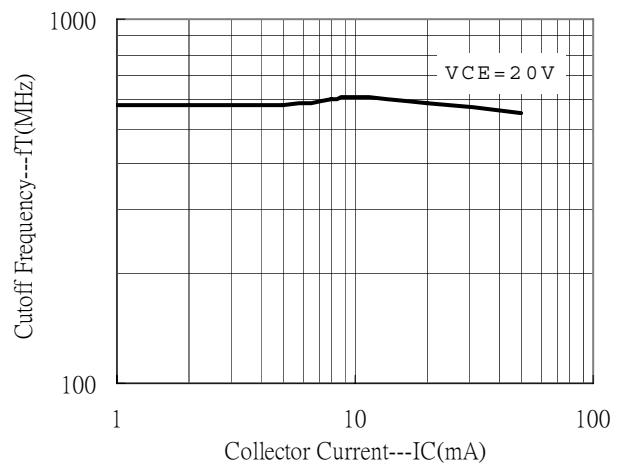

Power Derating Curve

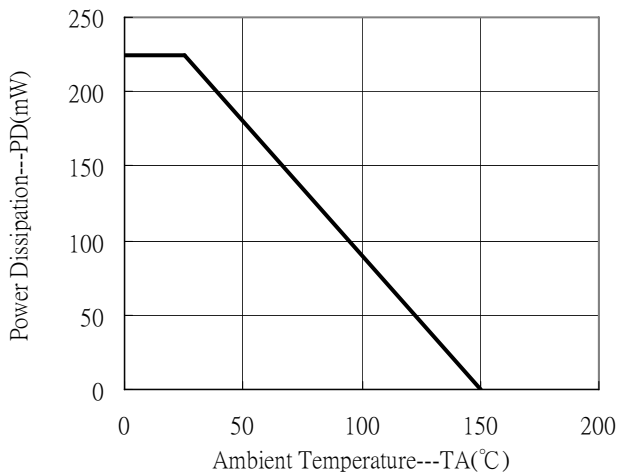

Reel Dimension

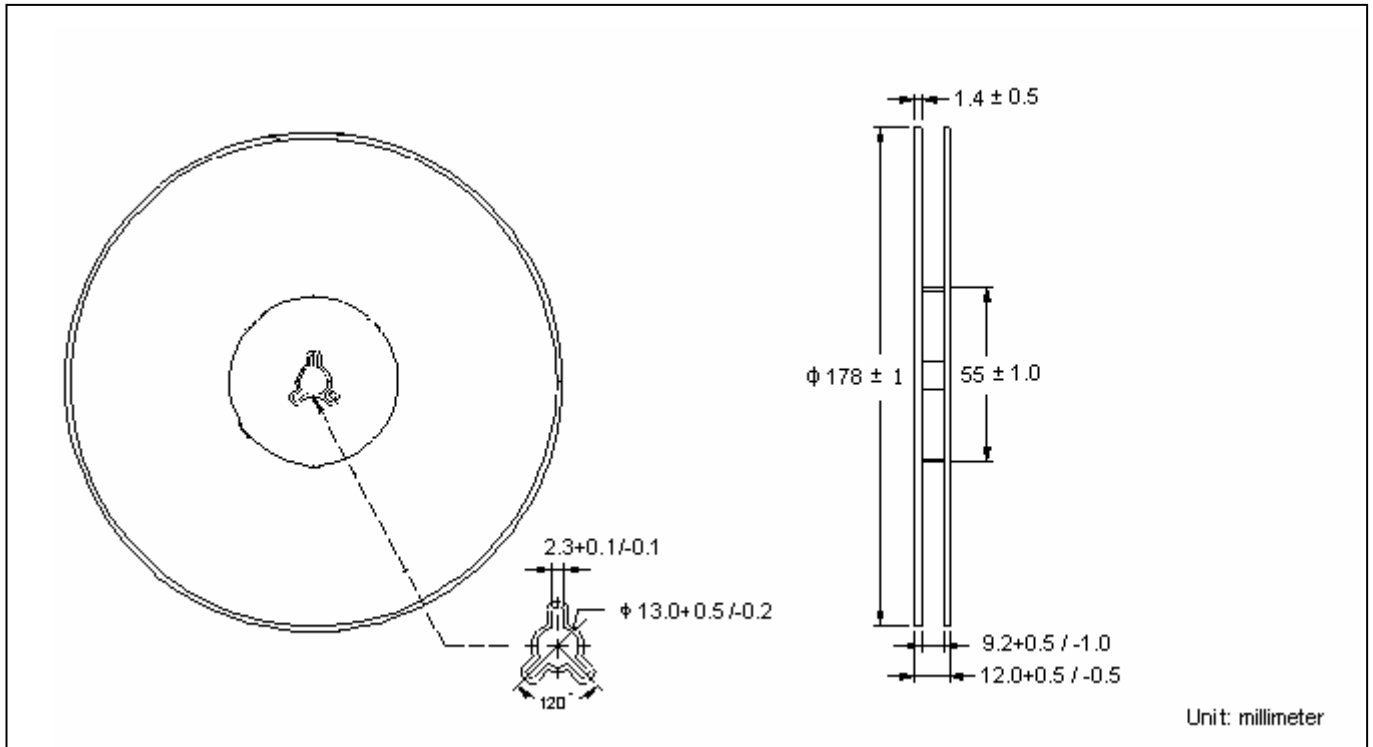

Carrier Tape Dimension

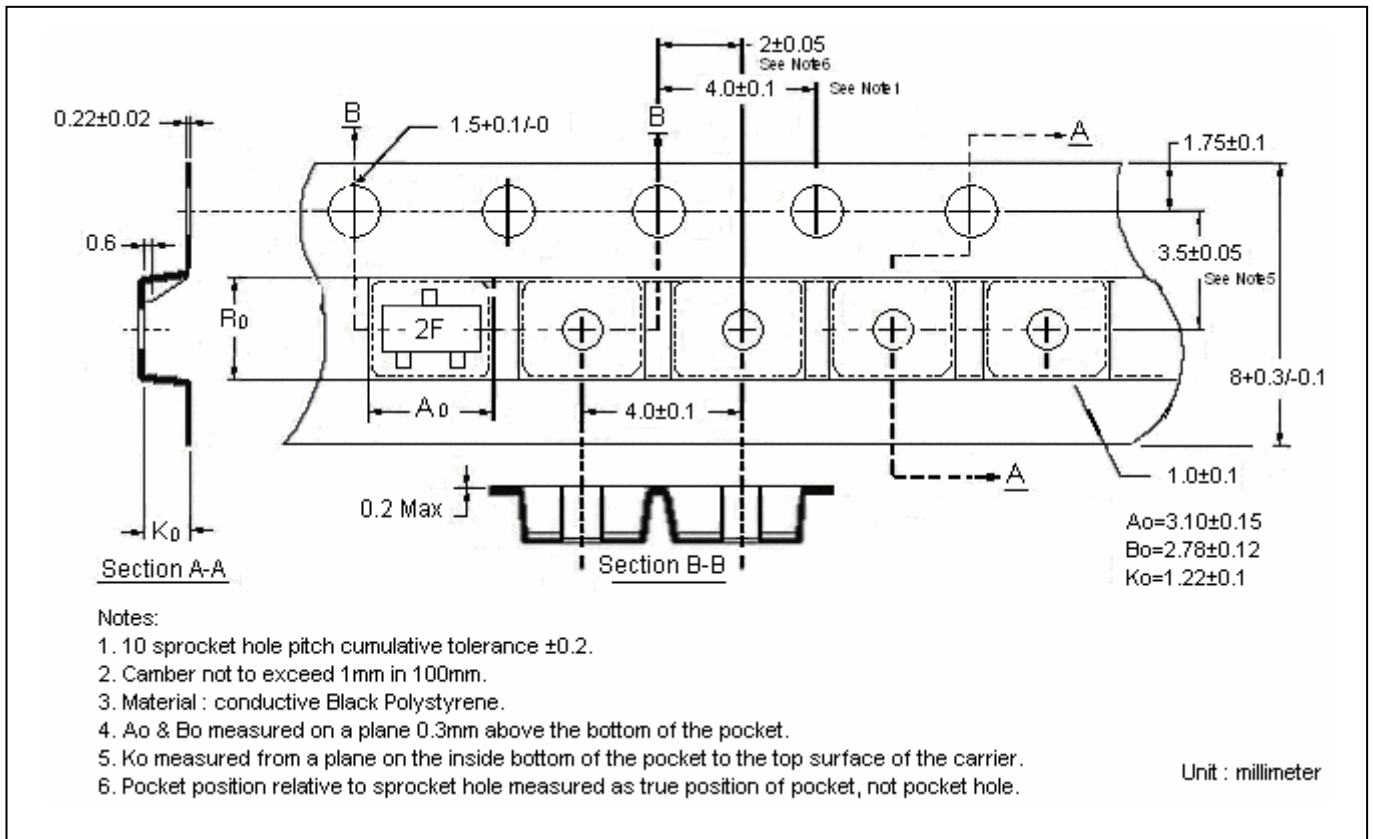



Recommended wave soldering condition

Product	Peak Temperature	Soldering Time
Pb-free devices	260 +0/-5 °C	5 +1/-1 seconds

Recommended temperature profile for IR reflow

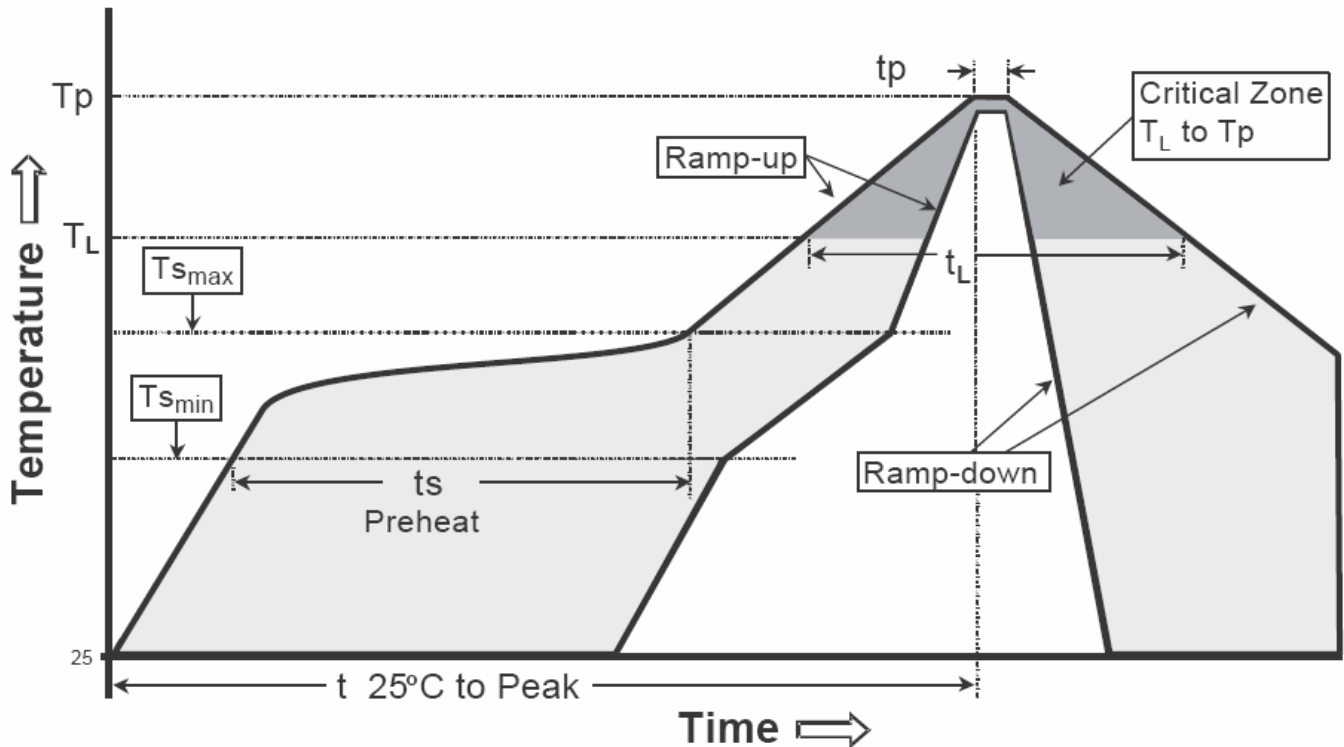

Profile feature	Sn-Pb eutectic Assembly	Pb-free Assembly
Average ramp-up rate (Tsmmax to Tp)	3°C/second max.	3°C/second max.
Preheat		
-Temperature Min(Ts min)	100°C	150°C
-Temperature Max(Ts max)	150°C	200°C
-Time(ts min to ts max)	60-120 seconds	60-180 seconds
Time maintained above:		
-Temperature (Tl)	183°C	217°C
- Time (tL)	60-150 seconds	60-150 seconds
Peak Temperature(Tp)	240 +0/-5 °C	260 +0/-5 °C
Time within 5°C of actual peak temperature(tp)	10-30 seconds	20-40 seconds
Ramp down rate	6°C/second max.	6°C/second max.
Time 25 °C to peak temperature	6 minutes max.	8 minutes max.

Note : All temperatures refer to topside of the package, measured on the package body surface.

SOT-23 Dimension

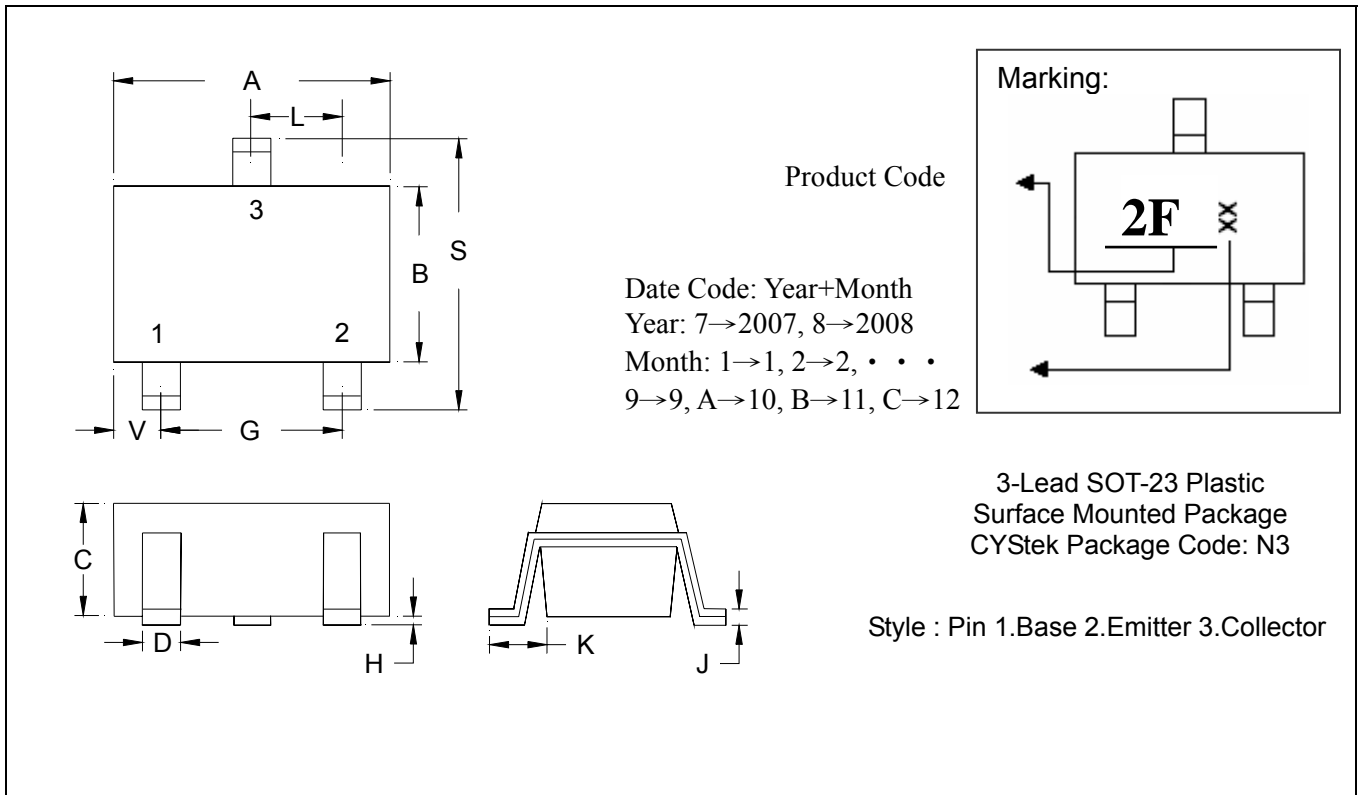

*:Typical

DIM	Inches		Millimeters		DIM	Inches		Millimeters	
	Min.	Max.	Min.	Max.		Min.	Max.	Min.	Max.
A	0.1102	0.1204	2.80	3.04	J	0.0034	0.0070	0.085	0.177
B	0.0472	0.0630	1.20	1.60	K	0.0128	0.0266	0.32	0.67
C	0.0335	0.0512	0.89	1.30	L	0.0335	0.0453	0.85	1.15
D	0.0118	0.0197	0.30	0.50	S	0.0830	0.1083	2.10	2.75
G	0.0669	0.0910	1.70	2.30	V	0.0098	0.0256	0.25	0.65
H	0.0005	0.0040	0.013	0.10					

Notes : 1.Controlling dimension : millimeters.
 2.Maximum lead thickness includes lead finish thickness, and minimum lead thickness is the minimum thickness of base material.
 3.If there is any question with packing specification or packing method, please contact your local CYStek sales office.

Material :

- Lead : 42 Alloy ; solder plating
- Mold Compound : Epoxy resin family, flammability solid burning class:UL94V-0

Important Notice:

- All rights are reserved. Reproduction in whole or in part is prohibited without the prior written approval of CYStek.
- CYStek reserves the right to make changes to its products without notice.
- CYStek **semiconductor products are not warranted to be suitable for use in Life-Support Applications, or systems.**
- CYStek assumes no liability for any consequence of customer product design, infringement of patents, or application assistance.